

**SOUTHERN CALIFORNIA EDISON COMPANY  
NET BILLING TARIFF OR NET ENERGY METERING AND RENEWABLE  
ELECTRICAL GENERATING FACILITY SIZED GREATER THAN ONE  
MEGAWATT INTERCONNECTION AGREEMENT  
ORANGE COUNTY SANITATION DISTRICT  
NST-497000**

This Net Billing Tariff (NBT) or Net Energy Metering and Generating Facility Interconnection Agreement (“Agreement”) is entered into by and between Orange County Sanitation District (“Customer”), and Southern California Edison Company (“SCE”), sometimes also referred to herein jointly as “Parties” or individually as “Party.”

**1. APPLICABILITY**

This Agreement is applicable only to Customers who satisfy all requirements of the definition of a Renewable Electrical Generating Facility (“Generating Facility”) sized greater than one megawatt (“MW”) as set forth in paragraph 1 of subdivision (a) of Section 25741 of the California Public Resources Code and who will be served according to the provisions of Schedule NBT or Schedule NEM-ST.

**2. SUMMARY OF GENERATING FACILITY AND CUSTOMER ACCOUNT**

- 2.1 Generating Facility Identification Number: NST-497000
- 2.2 Customer Meter Number: X345P-006016
- 2.3 Customer Service Account Number: 8015695676
- 2.4 Applicable Rate Schedule: TOU-8 Option D, Standby
- 2.5 Generating Facility Location: 22212 Brookhurst St, Huntington Beach, CA, 92646
- 2.5.1 This agreement is applicable only to the Generating Facility described below and installed at the above location. The Generating Facility may not be relocated or connected to SCE’s system at any other location without SCE’s express written permission.
- 2.5.2 This Agreement is applicable only to Renewable Electrical Generating Facilities, which includes biomass, solar thermal, photovoltaic, wind, geothermal, fuel cells (using renewable fuel), small hydroelectric generation, digester gas, municipal solid waste conversion, landfill gas, ocean wave, ocean thermal, or tidal current, and any additions or enhancements using such technology.
- 2.5.3 Renewable Electrical Generating Facilities using fuel cells, municipal solid waste conversion, and small hydroelectric generating will be required to sign an affidavit (Form 14-912) certifying the following criteria have been met:
- a) For purposes of this Agreement, qualifying “solid waste conversion” is defined pursuant to Public Resources Code Section 25741(b)(3).
  - b) For purposes of qualifying under “fuel cell” using renewable fuels, the Generating Facility must use technology the California Public Utilities Commission (“Commission”) determines will achieve reductions in emissions of greenhouse gases and meet emissions requirements for eligibility for funding pursuant to the Self-Generation Incentive Programs.

**SOUTHERN CALIFORNIA EDISON COMPANY  
NET BILLING TARIFF OR NET ENERGY METERING AND RENEWABLE  
ELECTRICAL GENERATING FACILITY SIZED GREATER THAN ONE  
MEGAWATT INTERCONNECTION AGREEMENT  
ORANGE COUNTY SANITATION DISTRICT  
NST-497000**

c) A “small hydroelectric” generating facility is not an eligible Generating Facility if it will cause an adverse impact on instream beneficial uses or cause a change in the volume or timing of streamflow.

2.6	Generating Facility Technology (technologies using the renewable resources reflected above): <u>Digester gas fueled cogeneration.</u>	
2.7	Generating Facility Nameplate Rating (kW):	<u>16,000 kW</u>
2.8	Generating Facility CEC-AC Rating or Equivalent (kW):	<u>16,000 kW</u>
2.9	Estimated annual energy production of the Generating Facility (kWh):	<u>110,160,000 kWh</u>
2.10	Existing Service: Total annual usage (kWh):	<u>2,582,772 kWh</u>

**3. NBT Generating Facility Size Attestation for Existing Service**

3.1 The Generating Facility should be sized such that the total annual output in kWh is primarily used to offset the customer’s own annual electrical requirements. For a customer with a SCE account that has 12 or more months of billing history, the most recent 12 months usage is used to determine the estimated size of the Generating Facility. Should the customer elect to oversize their Generating Facility (as compared to the 12-month usage history), the following attestation is required when seeking service under Schedule NBT:

3.2 By initialing each line in the section below, I attest to the following:

- \_\_\_\_\_ The Generating Facility is oversized to meet my expected increased future electrical usage (i.e., increased usage resulting from an electric vehicle or other electrical appliances to support electrification).
- \_\_\_\_\_ The Generating Facility’s estimated annual production in kWh is no larger than 150 percent of my most recent 12 months of total usage.
- \_\_\_\_\_ I expect to increase my electrical usage to correspond with the size of my Generating Facility within the next year (12 months after receiving Permission to Operate (PTO)).
- \_\_\_\_\_ I have recently increased my electrical usage and my Generating Facility’s estimated annual production in kWh is no larger than 150 percent of my current projected electrical usage over 12 months. This means that additional electrical usage is planned so that my Generating Facility’s annual kWh production is not expected to exceed 150 percent of my current usage projected over the first 12 months after PTO.
- \_\_\_\_\_ I understand that SCE reserves the right to further validate that the Generating Facility is sized in accordance with Schedule NBT.

**4. NBT Generating Facility Size Attestation for New service or Customers with Less than 12-Month of Usage History**

**SOUTHERN CALIFORNIA EDISON COMPANY  
NET BILLING TARIFF OR NET ENERGY METERING AND RENEWABLE  
ELECTRICAL GENERATING FACILITY SIZED GREATER THAN ONE  
MEGAWATT INTERCONNECTION AGREEMENT  
ORANGE COUNTY SANITATION DISTRICT  
NST-497000**

4.1 The Generating Facility should be sized such that the total annual output in kWh is primarily used to offset the customer's own annual electrical requirements. For a new customer, or a customer with less than 12 months of billing history, the following attestation is required when seeking service under Schedule NBT:

4.2 By initialing each line in the section below, I attest to the following:

- \_\_\_\_\_ The Generating Facility is sized to meet expected my future electrical usage.
- \_\_\_\_\_ I expect that my electrical usage will correspond to the size of the Generating Facility within the next year (12 months after receiving Permission to Operate (PTO)).
- \_\_\_\_\_ I understand that SCE reserves the right to further validate that the Generating Facility is sized in accordance with Schedule NBT.

**5. GENERATING FACILITY INTERCONNECTION AND DESIGN REQUIREMENTS:**

- 5.1 Customer shall be responsible for the design, installation, operation, and maintenance of the Generating Facility and shall obtain and maintain any required governmental authorizations and/or permits.
- 5.2 Customer shall be responsible for all applicable study costs as outlined in SCE's Electric Tariff Rule 21 – *Generating Facility Interconnections* ("Rule 21").
- 5.3 If the studies conducted pursuant to the applicable provisions of Rule 21 result in the need for upgrades to SCE's Distribution and/or Transmission System, SCE shall be afforded the time necessary to complete those upgrades before issuing written approval allowing the Customer to operate the Generating Facility. Costs for those upgrades and any necessary Interconnection Facilities shall be borne by the Customer, pursuant to the terms and conditions outlined in Attachments A and B of this Agreement.
- 5.4 The Generating Facility shall meet all applicable safety and performance standards established by the National Electrical Code, the Institute of Electrical and Electronics Engineers ("IEEE"), and accredited testing laboratories such as Underwriters Laboratories ("UL"), and, where applicable, rules of the Commission regarding safety and reliability. This requirement shall include, but not be limited to, the provisions of IEEE Standard 929, UL Standard 1741 and SCE's Electric Rule 21 – *Generating Facility Interconnections*.
- 5.5 The Generating Facility must have a warranty of at least 10 years for all equipment and the associated installation from the system provider. Warranties or service agreements conforming to requirements applicable to the Self-Generation Incentive Program ("SGIP") may be used for technologies eligible for the SGIP. In appropriate circumstances conforming to industry practice, this requirement may also rely on and be satisfied by manufacturers' warranties for equipment and separate contractors' warranties for workmanship (i.e., installation).
- 5.6 All major solar system components (including PV panels and other generation equipment, inverters and meters) must be on the verified equipment list maintained by the California Energy Commission ("CEC"). Any other equipment, as determined by SCE, must be

**SOUTHERN CALIFORNIA EDISON COMPANY  
NET BILLING TARIFF OR NET ENERGY METERING AND RENEWABLE  
ELECTRICAL GENERATING FACILITY SIZED GREATER THAN ONE  
MEGAWATT INTERCONNECTION AGREEMENT  
ORANGE COUNTY SANITATION DISTRICT  
NST-497000**

verified as having safety certification from a Nationally Recognized Testing Laboratory (“NRTL”).

- 5.7 Customer shall not commence parallel operation of the Generating Facility until written approval has been provided to it by SCE.
- 5.8 SCE shall have the right to have its representatives present at the final inspection made by the local authority having jurisdiction to inspect and approve the installation of the Generating Facility.
- 5.9 Customer shall not add generation capacity in excess of the ratings set forth in Sections 2.7 and 2.8 of this Agreement, or otherwise modify the Generating Facility without the prior written permission of SCE.

**6. METERING AND BILLING:**

Metering requirements and billing procedures shall be set forth in the SCE, Electric Service Provider's, Community Choice Aggregator's and/or Community Aggregator's rate schedule(s) applicable to the electric service account assigned to the location where the Generating Facility is connected.

**7. DISCONNECTION, INTERRUPTION OR REDUCTION OF DELIVERIES:**

- 7.1 SCE may require Customer to interrupt or reduce the output of its Generating Facility under the following circumstances:
  - (a) Whenever SCE deems it necessary in its sole judgment, to construct, install, maintain, repair, replace, remove, investigate, or inspect any of its equipment or any part of its electric system; or
  - (b) Whenever SCE determines in its sole judgment, that curtailment, interruption, or reduction of Customer's electrical generation is otherwise necessary due to emergencies, forced outages, force majeure, or compliance with prudent electrical practices.
- 7.2 Notwithstanding any other provision of this Agreement, upon termination of this Agreement or at any time SCE determines the continued parallel operation of the Generating Facility may endanger the public or SCE personnel, or affect the integrity of SCE's electric system or the quality of electric service provided to other customers, SCE shall have the right to require the Generating Facility to be immediately disconnected from SCE's electric system. The Generating Facility shall remain disconnected until such time as SCE is satisfied, in its sole judgment that the condition(s) causing such disconnection have ended or have been corrected.
- 7.3 Whenever feasible, SCE shall give Customer reasonable notice of the possibility that interruption or reduction of deliveries may be required.
- 7.4 Electrical energy and capacity provided to Customer during periods of curtailment or interruption of the output of the Generating Facility shall be provided pursuant to the terms

**SOUTHERN CALIFORNIA EDISON COMPANY  
NET BILLING TARIFF OR NET ENERGY METERING AND RENEWABLE  
ELECTRICAL GENERATING FACILITY SIZED GREATER THAN ONE  
MEGAWATT INTERCONNECTION AGREEMENT  
ORANGE COUNTY SANITATION DISTRICT  
NST-497000**

of the rate schedule(s) applicable to the electric service account to which the Generating Facility is connected.

**8. ACCESS TO PREMISES:**

SCE may enter Customer's premises at all times, without notice to Customer for emergency purposes only.

- (a) To inspect Customer's protective devices or check meter(s); to ascertain there is no power flow; or
- (b) To disconnect the Generating Facility and/or service to Customer, whenever in SCE's discretion, a hazardous condition exists and such immediate action is necessary to protect persons, SCE's facilities, or property of others from damage or interference caused by the Generating Facility, or the failure of properly operating protective devices.

SCE will make prior arrangements with the Customer for gaining emergency access to Customer's premises by obtaining keys to a lock box or a padlock or by making other mutually agreeable arrangements.

**9. INSURANCE**

9.1 In connection with Customer's performance of its duties and obligations under this Agreement, Customer shall maintain, during the term of this Agreement, commercial general liability insurance with a limit of two million dollars (\$2,000,000) for each occurrence.

Such commercial general liability insurance shall include coverage for Premises-Operations and Contractual Liability.

9.2 The commercial general liability insurance required in Section 9.1 shall, by endorsement to the policy or within the policy general condition itself, (a) include SCE as an additional insured; (b) contain a severability of interest clause or cross-liability clause; (c) provide that SCE shall not by reason of its inclusion as an additional insured incur liability to the insurance carrier for payment of premium for such insurance; (d) that coverage provided is primary and not in excess to or contributing with any insurance or self-insurance maintained by SCE; (e) waiver of subrogation shall be granted to SCE; and (f) provide for thirty (30) calendar days' written notice to SCE prior to cancellation, termination, alteration, or material change of such insurance.

9.3 [Intentionally Blank]

9.4 Customer agrees to furnish evidence of insurance (certificates of insurance and endorsements as appropriate) to SCE prior to Parallel Operation, and thereafter for each insurance policy renewal during the term of this Agreement. SCE shall have the right to inspect or obtain a copy of the original policy or policies of insurance.

9.5 If Customer is self-insured with an established record of self-insurance, Customer may comply with the following in lieu of Sections 9.1 through 9.2:

**SOUTHERN CALIFORNIA EDISON COMPANY  
NET BILLING TARIFF OR NET ENERGY METERING AND RENEWABLE  
ELECTRICAL GENERATING FACILITY SIZED GREATER THAN ONE  
MEGAWATT INTERCONNECTION AGREEMENT  
ORANGE COUNTY SANITATION DISTRICT  
NST-497000**

- (a) Customer shall provide to SCE, at least thirty (30) calendar days prior to the date of Parallel Operation, evidence of an acceptable plan to self-insure to a level of coverage equivalent to that required under Section 9.1.
  - (b) If Customer ceases to self-insure to the level required hereunder, or if Customer is unable to provide continuing evidence of Producer's ability to self-insure, Customer agrees to immediately obtain the insurance coverage required under Section 9.1 and 9.2 above.
- 9.6 All insurance policies, certificates of insurance, statements of self-insurance, endorsements, cancellations, terminations, alterations, and material changes of such insurance shall be issued and submitted to the following:

Southern California Edison Company  
Attention: NBT Program Administrator  
SCE Customer Solar & Self Generation  
P.O. Box 800  
Rosemead, CA 91770

**10. LIABILITY:**

- 10.1 Each Party as indemnitor shall defend, hold harmless, and indemnify the other Party and the directors, officers, employees, and agents of the other Party against and from any and all loss, liability, damage, claim, cost, charge, demand, or expense (including any direct, indirect or consequential loss, liability, damage, claim, cost, charge, demand, or expense, including attorneys' fees) for injury or death to persons, including employees of either Party, and damage to property, including property of either Party, arising out of or in connection with (a) the engineering, design, construction, maintenance, repair, operation, supervision, inspection, testing, protection or ownership of the indemnitor's facilities, or (b) the making of replacements, additions, betterments to, or reconstruction of the indemnitor's facilities. This indemnity shall apply notwithstanding the active or passive negligence of the indemnitee. However, neither Party shall be indemnified hereunder for its loss, liability, damage, claim, cost, charge, demand, or expense resulting from its sole negligence or willful misconduct.
- 10.2 The indemnitor shall, on the other Party's request, defend any suit asserting a claim covered by this indemnity and shall pay for all costs, including reasonable attorney fees, that may be incurred by the other Party in enforcing this indemnity.
- 10.3 The provisions of this Section shall not be construed to relieve any insurer of its obligations to pay any insurance claims in accordance with the provisions of any valid insurance policy.
- 10.4 Except as otherwise provided in Section 10.1, neither Party shall be liable to the other Party for consequential damages incurred by that Party.
- 10.5 Nothing in this Agreement shall create any duty to, any standard of care with reference to, or any liability to any person who is not a Party to it.

**SOUTHERN CALIFORNIA EDISON COMPANY  
NET BILLING TARIFF OR NET ENERGY METERING AND RENEWABLE  
ELECTRICAL GENERATING FACILITY SIZED GREATER THAN ONE  
MEGAWATT INTERCONNECTION AGREEMENT  
ORANGE COUNTY SANITATION DISTRICT  
NST-497000**

10.6 Notwithstanding the provisions of Section 10.1, Customer shall be responsible for protecting its Generating Facility from damage by reason of the electrical disturbances or faults caused by the operation, faulty operation, or non-operation of SCE's facilities, and SCE shall not be liable for any such damage so caused.

**11. GOVERNING LAW:**

This Agreement shall be interpreted, governed, and construed under the laws of the State of California as if executed and to be performed wholly within the State of California.

**12. CALIFORNIA PUBLIC UTILITIES COMMISSION:**

12.1 This Agreement shall at all times be subject to such changes or modifications by the Commission as the Commission may, from time to time, direct in the exercise of its jurisdiction.

12.2 Notwithstanding any other provisions of this Agreement, SCE has the right to unilaterally file with the Commission, pursuant to the Commission's rules and regulations, an application for change in rates, charges, classification, service, or rule or any agreement relating thereto.

**13. AMENDMENT, MODIFICATIONS, WAIVER OR ASSIGNMENT:**

13.1 This Agreement may not be altered or modified by either of the Parties, except by an instrument in writing executed by each of them.

13.2 None of the provisions of this Agreement shall be considered waived by a Party unless such waiver is given in writing. The failure of a Party to insist in any one or more instances upon strict performance of any of the provisions of this Agreement or to take advantage of any of its rights hereunder shall not be construed as a waiver of any such provisions or the relinquishment of any such rights for the future, but the same shall continue and remain in full force and effect.

13.3 This Agreement shall supersede any existing agreement under which Customer is currently operating the Generating Facility identified in Section 2, herein, and any such agreement shall be deemed terminated as of the date this Agreement becomes effective.

13.4 This Agreement contains the entire agreement and understanding between the Parties, their agents, and employees as to the subject matter of this Agreement. Each party also represents that in entering into this Agreement, it has not relied on any promise, inducement, representation, warranty, agreement or other statement not set forth in this Agreement.

13.5 This Agreement shall not be assigned if such assignment would cause the Generating Facility to not comply with the provisions of Public Utilities Code Section 2827.1. The Customer shall not voluntarily assign its rights or delegate its duties under this Agreement without SCE's written consent. Any assignment or delegation Customer makes without SCE's written consent shall not be valid. SCE shall not unreasonably withhold its consent to Customer's assignment of this Agreement.

**SOUTHERN CALIFORNIA EDISON COMPANY  
NET BILLING TARIFF OR NET ENERGY METERING AND RENEWABLE  
ELECTRICAL GENERATING FACILITY SIZED GREATER THAN ONE  
MEGAWATT INTERCONNECTION AGREEMENT  
ORANGE COUNTY SANITATION DISTRICT  
NST-497000**

**14. NOTICES:**

- 14.1 Any notice required under this Agreement shall be in writing and mailed at any United States Post Office with postage prepaid and addressed to the Party, or personally delivered to the Party, at the address below. Changes in such designation may be made by notice similarly given. All written notices shall be directed as follows:

**SOUTHERN CALIFORNIA EDISON COMPANY:**

Attn: NBT Program Administrator  
SCE Customer Solar & Self Generation  
P.O. Box 800  
Rosemead, CA 91770

**CUSTOMER:**

Account Name: Orange County Sanitation District  
Mailing Address 10844 Ellis Ave  
Mailing City: Fountain Valley Mailing State: CA  
Mailing Zip Code: 92646

- 14.2 Customer's notices to SCE pursuant to this Section shall refer to the Generating Facility Identification Number that is set forth in Section 2.1

**15. TERM AND TERMINATION OF AGREEMENT:**

- 15.1 This Agreement shall become effective when SCE issues written authorization to interconnect the Generating Facility after receipt of all required documents and payments, and this completed Agreement is signed by the Customer and SCE, and shall remain in effect thereafter from month to month unless terminated by either Party on thirty (30) days' prior written notice in accordance with Section 14.
- 15.2 This Agreement shall terminate, without notice, upon: (a) termination of the electric distribution service provided to Customer by SCE; or (b) changes to Customer's electric load which cause the Customer to no longer satisfy all requirements of the definition of an Eligible Customer-Generator, as set forth in Section 2827.1(a) of the California Public Utilities Code; or (c) termination of Customer's Net Billing Tariff or Net Energy Metering arrangements with its Electric Service Provider, Community Choice Aggregator and/or Community Aggregator.
- 15.3 Pursuant to Public Utilities (PU) Code Section 769.2 and California Public Utilities Commission (CPUC or Commission) Decision 23-11-068, if the Customer-Generator's contractor is found to have willfully violated Section 769.2 of the PU Code by failing to pay its workers a prevailing wage, the Renewable Electrical Generating Facility is ineligible to participate on a tariff developed pursuant to PU Code Sections 2827 or 2827.1. Upon notice of a determination of a willful violation of Section 769.2 by the Department of Industrial Relations or a court, SCE shall transition the Renewable Electrical Generating Facility (after the required 30/60-day notification)<sup>1</sup> to the Public Utility Regulatory Policies Act of 1978

<sup>1</sup> Pursuant to Decision 23-11-068, Customers with single generating account with no benefitting/aggregated account will get a 30-day notice. Customers with single generating account with benefitting/aggregated accounts will get a 60-day notice



**SOUTHERN CALIFORNIA EDISON COMPANY  
NET BILLING TARIFF OR NET ENERGY METERING AND RENEWABLE  
ELECTRICAL GENERATING FACILITY SIZED GREATER THAN ONE  
MEGAWATT INTERCONNECTION AGREEMENT  
ORANGE COUNTY SANITATION DISTRICT  
NST-497000**

(PURPA) compliant tariff. All the terms and conditions of this agreement will remain in effect except that the Customer will not receive billing under tariffs developed pursuant to 2827 or 2827.1, including but not limited to NEM or NBT.

The Customer has the right to choose an alternate applicable tariff before or after the transition. If the Customer does not choose another applicable tariff in advance of the next billing cycle, the billing will transition to the PURPA compliant tariff to avoid any delay in billing. Customer will remain on the PURPA compliant tariff (or other applicable tariff if available and chosen by the Customer unless the willful wage violation is reversed or nullified by the determining body.

This provision does not apply to the following Customers that are being served by tariffs pursuant to PU Code 2827 and 2827.1:

- (1) Residential Renewable Electrical Generating Facilities that have a maximum generating capacity of 15 kilowatts or less of electricity;
- (2) Residential Renewable Electrical Generating Facilities installed on a single-family home;
- (3) Public Work projects that are subject to Article 2 of Chapter 1 of Part 7 of Division 2 of the Labor Code;
- (4) Renewable Electrical Generating Facilities that serve only a modular home, a modular home community, or multi-unit housing that has two or fewer stories.

**16. TRANSITION PROVISIONS:**

- 16.1 Customers receiving service on Schedule NEM-ST, or who have submitted all documentation necessary for receiving service on Schedule NEM-ST, are subject to the transition provisions as outlined therein.
- 16.2 Customers receiving service on Schedule NBT, or who submit application on or after April 15, 2023 are subject to the transition provisions as outlined therein.

**17. REQUIRED DISCLOSURE:**

This Agreement is subject to SCE's Rule 21 protocols, including the Confidentiality provisions (Section D.7) and the Required Disclosure (Section D.7.d). As a condition of interconnection, pursuant to the California Public Utilities Commission (CPUC) Decisions (D).14-11-001 and D.21-06-026, SCE is required to provide certain data, including, but not limited to, confidential customer information, to the CPUC, its contractors, the California Department of Consumer Affairs Contractors State License Board, the California Department of Financial Protection & Innovation and the Department of Industrial Relations. Customer authorizes SCE to release any and all information contained in the application for interconnection to the entities identified above without further notification or consent.

**18. SIGNATURES:**

This Agreement may be executed in counterparts, and by Electronic Signature on the part of SCE and/or the Customer, and copies of a Party's signed signature page may be transmitted to the other Party by facsimile or other electronic means. Copies of the signature page so transmitted may be used for the purpose of enforcing the terms of this Agreement as though they were originals and



**SOUTHERN CALIFORNIA EDISON COMPANY**  
**NET BILLING TARIFF OR NET ENERGY METERING AND RENEWABLE**  
**ELECTRICAL GENERATING FACILITY SIZED GREATER THAN ONE**  
**MEGAWATT INTERCONNECTION AGREEMENT**  
**ORANGE COUNTY SANITATION DISTRICT**  
NST-497000

will not be made inadmissible in any legal or regulatory proceeding concerning this Agreement on the basis of the Best Evidence Rule or similar rule of admissibility.

IN WITNESS WHEREOF, the Parties hereto have caused this Agreement to be executed by their duly authorized representatives. This Agreement is effective as provided in Section 15.1 above.

**ORANGE COUNTY SANITATION DISTRICT**

**SOUTHERN CALIFORNIA EDISON COMPANY**

By: \_\_\_\_\_  
Name:                     Ryan P. Gallagher                      
Title:                     Board Chairman                      
Date: \_\_\_\_\_

By: \_\_\_\_\_  
Name:                     Marcus Lotto                      
Title:                     Senior Manager, Grid Interconnection  
                            & Contract Development                      
Date: \_\_\_\_\_

**ATTEST:**

By: \_\_\_\_\_  
Name:                     Kelly A. Lore, MMC                      
Title:                     Clerk of the Board                      
Date: \_\_\_\_\_

**APPROVED AS TO FORM:**

By: \_\_\_\_\_  
Name:                     Scott C. Smith                      
Title:                     General Counsel                      
Date: \_\_\_\_\_



**SOUTHERN CALIFORNIA EDISON COMPANY  
NET BILLING TARIFF OR NET ENERGY METERING AND RENEWABLE  
ELECTRICAL GENERATING FACILITY SIZED GREATER THAN ONE  
MEGAWATT INTERCONNECTION AGREEMENT  
ORANGE COUNTY SANITATION DISTRICT  
NST-497000**

**ATTACHMENT A**

Additional Terms and Conditions for Projects Requiring  
Interconnection Facilities and/or Upgrades to SCE's Distribution and/or Transmission System

REFERENCE COPY

## **Section 1. Cost Responsibility for Interconnection Facilities and Distribution Upgrades**

### **1.1 Interconnection Facilities**

- 1.1.1 The Customer shall pay for the cost of the Interconnection Facilities itemized in Attachment A-1 below and as provided, where applicable, in the Facilities Financing and Ownership Agreement (“FFOA”) incorporated as Attachment B below. SCE shall provide a best estimate cost, including a cost estimate pursuant to the Cost Envelope Option provisions of Rule 21, Section F.7, if applicable, including overheads any applicable Income Tax Component of Contribution (ITCC), for the purchase and construction of its Interconnection Facilities and provide a detailed itemization of such costs. Costs associated with Interconnection Facilities may be shared with other entities that may benefit from such facilities by agreement of the Customer, such other entities, and SCE. Customers who elected the Cost Envelope Option will be subject to the provisions of Rule 21, Section F.7, as applicable, for the determination of actual costs
- 1.1.2 The Customer shall be responsible for its share of all reasonable expenses, including overheads and any applicable ITCC, associated with (1) owning, operating, maintaining, repairing, and replacing its own Interconnection Facilities, and (2) operating, maintaining, repairing, and replacing SCE's Interconnection Facilities.

### **1.2 Distribution Upgrades**

- 1.2.1 No portion of this Section 1.2 shall apply unless the interconnection of the Generating Facility requires Distribution Upgrades.
- 1.2.2 SCE shall design, procure, construct, install, and own the Distribution Upgrades described in Attachment A-2 below and as provided, where applicable, in the FFOA incorporated as Attachment B below. If SCE and the Customer agree, the Customer may construct Distribution Upgrades that are located on land owned by the Customer. The actual cost of the Distribution Upgrades, including overheads and any applicable IITCC, shall be directly assigned to the Customer. Customers who elected the Cost Envelope Option will be subject to the provisions of Rule 21, Section F.7, as applicable, for the determination of actual costs.

## **Section 2. Cost Responsibility for Network Upgrades**

### **2.1 Applicability**

No portion of this Section 2 shall apply unless the interconnection of the Generating Facility requires Network Upgrades.

### **2.2 Network Upgrades**

SCE shall design, procure, construct, install, and own the Network Upgrades described in Attachment A-2 below and as provided, where applicable, in the FFOA incorporated as Attachment B below. If SCE and the Customer agree, the Customer may construct Network Upgrades that are located on land owned by the Customer. Unless SCE elects to pay for Network Upgrades, the actual cost of the Network Upgrades, including overheads, shall be borne by the Customer unless Section 2.2.1 directs otherwise.

### **2.2.1 Repayment of Amounts Advanced for Network Upgrades**

To the extent that the CAISO Tariff, currently Section 14.3.2 of Appendix DD, provides for cash repayment to interconnection customers for contribution to the cost of Network Upgrades, the Customer shall be entitled to a cash repayment, equal to the total amount paid to SCE and Affected System operator, if any, for Network Upgrades, including any tax gross-up or other tax-related payments associated with the Network Upgrades, and not otherwise refunded to the Customer, to be paid to the Customer on a dollar-for-dollar basis for the non-usage sensitive portion of transmission charges, as payments are made under SCE's tariff and Affected System's tariff for transmission services with respect to the Generating Facility.

Any repayment shall include interest calculated in accordance with the methodology set forth in FERC's regulations at 18 C.F.R. §35.19a(a)(2)(iii) from the date of any payment for Network Upgrades through the date on which the Customer receives a repayment of such payment pursuant to this subparagraph. The Customer may assign such repayment rights to any person. To the extent that the CAISO Tariff does not provide for cash repayment to interconnection customers for contribution to the cost of Network Upgrades, Customer is not entitled to a cash repayment for amounts paid to SCE and Affected System operator for Network Upgrades, and no cash repayment shall be made pursuant to this Agreement.

2.2.1.1 If the Customer is entitled to a cash repayment pursuant to Section 2.2.1, the Customer, SCE, and any applicable Affected System operators may adopt any alternative payment schedule that is mutually agreeable so long as SCE and said Affected System operators take one of the following actions no later than five years from the Commercial Operation Date: (1) return to the Customer any amounts advanced for Network Upgrades not previously repaid, or (2) declare in writing that SCE or any applicable Affected System operators will continue to provide payments to the Customer on a dollar-for-dollar basis for the non-usage sensitive portion of transmission charges, or develop an alternative schedule that is mutually agreeable and provides for the return of all amounts advanced for Network Upgrades not previously repaid; however, full reimbursement shall not extend beyond twenty (20) years from the Commercial Operation Date.

2.2.1.2 If the Generating Facility fails to achieve commercial operation, but it or another generating facility is later constructed and requires use of the Network Upgrades, SCE and Affected System operator shall at that time reimburse the Customer for the amounts advanced for the Network Upgrades if the Customer is entitled to a cash repayment pursuant to Section 2.2.1. Before any such reimbursement can occur, the Customer, or the entity that ultimately constructs the generating facility, if different, is responsible for identifying the entity to which reimbursement must be made.

### **2.3 Rights Under Other Agreements**

**SOUTHERN CALIFORNIA EDISON COMPANY  
NET BILLING TARIFF OR NET ENERGY METERING AND RENEWABLE  
ELECTRICAL GENERATING FACILITY SIZED GREATER THAN ONE  
MEGAWATT INTERCONNECTION AGREEMENT  
ORANGE COUNTY SANITATION DISTRICT  
NST-497000**

Notwithstanding any other provision of this Agreement, nothing herein shall be construed as relinquishing or foreclosing any rights, including but not limited to firm transmission rights, capacity rights, transmission congestion rights, or transmission credits, that the Customer shall be entitled to, now or in the future, under any other agreement or tariff as a result of, or otherwise associated with, the transmission capacity, if any, created by the Network Upgrades, including the right to obtain cash reimbursements or transmission credits for transmission service that is not associated with the Generating Facility.

### **Section 3. Billing, Payment, Milestones, and Financial Security**

#### **3.1 Billing and Payment Procedures and Final Accounting**

SCE shall bill the Customer for the design, engineering, construction, and procurement costs, including any applicable ITCC and/or other taxes, of Interconnection Facilities and Distribution and/or Network Upgrades contemplated by this Agreement pursuant to the FFOA, or as otherwise agreed by the Parties.

#### **3.2 Milestones**

The Parties shall agree on milestones for which each Party is responsible and list them in Attachment A-3 below. A Party's obligations under this provision may be extended by agreement. If a Party anticipates that it will be unable to meet a milestone for any reason other than a Uncontrollable Force Event, it shall immediately notify the other Party of the reason(s) for not meeting the milestone and (1) propose the earliest reasonable alternate date by which it can attain this and future milestones, and (2) requesting appropriate amendments to Attachment A-3 below. The Party affected by the failure to meet a milestone shall not unreasonably withhold agreement to such an amendment unless it will suffer significant uncompensated economic or operational harm from the delay, (2) attainment of the same milestone has previously been delayed, or (3) it has reason to believe that the delay in meeting the milestone is intentional or unwarranted notwithstanding the circumstances explained by the Party proposing the amendment.

#### **3.3 Financial Security Arrangements**

At least 20 Business Days prior to the commencement of the design, procurement, installation, or construction of a discrete portion of SCE's Interconnection Facilities and Distribution and/or Network Upgrades, the Customer shall provide SCE, at the Customer's option, a guarantee, a surety bond, letter of credit or other form of security that is reasonably acceptable to SCE and is consistent with the Uniform Commercial Code of the jurisdiction where the Point of Interconnection is located. Such security for payment shall be in an amount sufficient to cover the costs for constructing, designing, procuring, and installing the applicable portion of the SCE's Interconnection Facilities and Distribution and/or Network Upgrades and shall be reduced on a dollar-for-dollar basis for payments made to SCE under this Agreement during its term. In addition:

- 3.3.1 The guarantee must be made by an entity that meets the creditworthiness requirements of SCE, and contain terms and conditions that guarantee payment of any amount that may be due from the Customer, up to an agreed-to maximum amount.
- 3.3.2 The letter of credit or surety bond must be issued by a financial institution or insurer reasonably acceptable to SCE and must specify a reasonable expiration date.

## **Section 4. Taxes**

### **4.1 Applicable Tax Laws and Regulation**

The Parties agree to follow all applicable tax laws and regulations, consistent with Commission policy and Internal Revenue Service requirements.

### **4.2 Maintenance of Tax Status**

Each Party shall cooperate with the other to maintain the other Party's tax status. Nothing in this Agreement is intended to adversely affect SCE's tax exempt status with respect to the issuance of bonds including, but not limited to, local furnishing bonds.

## **Section 5. Environmental Releases**

Each Party shall notify the other Party, first orally and then in writing, of the release of any hazardous substances, any asbestos or lead abatement activities, or any type of remediation activities related to the Generating Facility or the Interconnection Facilities, each of which may reasonably be expected to affect the other Party. The notifying Party shall (1) provide the notice as soon as practicable, provided such Party makes a good faith effort to provide the notice no later than 24 hours after such Party becomes aware of the occurrence, and (2) promptly furnish to the other Party copies of any publicly available reports filed with any governmental authorities addressing such events.

## **Section 6. Subcontractors**

Nothing in this Agreement shall prevent a Party from utilizing the services of any subcontractor as it deems appropriate to perform its obligations under this Agreement; provided, however, that each Party shall require its subcontractors to comply with all applicable terms and conditions of this Agreement in providing such services and each Party shall remain primarily liable to the other Party for the performance of such subcontractor.

- 6.1 The creation of any subcontract relationship shall not relieve the hiring Party of any of its obligations under this Agreement. The hiring Party shall be fully responsible to the other Party for the acts or omissions of any subcontractor the hiring Party hires as if no subcontract had been made; provided, however, that in no event shall SCE be liable for the actions or inactions of the Customer or its subcontractors with respect to obligations of the Customer under this Agreement. Any applicable obligation imposed by this Agreement upon the hiring Party shall be equally binding upon, and shall be construed as having application to, any subcontractor of such Party.
- 6.2 The obligations under this article will not be limited in any way by any limitation of subcontractor's insurance.

**SOUTHERN CALIFORNIA EDISON COMPANY  
NET BILLING TARIFF OR NET ENERGY METERING AND RENEWABLE  
ELECTRICAL GENERATING FACILITY SIZED GREATER THAN ONE  
MEGAWATT INTERCONNECTION AGREEMENT  
ORANGE COUNTY SANITATION DISTRICT  
NST-497000**

**Attachment A-1**

**Description and Costs of the Generating Facility,  
Interconnection Facilities, and Metering Equipment**

**Recitals**

**This Agreement is made with reference to the following facts, among others:**

**WHEREAS**, the Customer owns and operates the Generating Facility that is described below in Section 1 of this Attachment A-1 to this Agreement.

**WHEREAS**, Customer (as successor-in-interest to County Sanitation Districts of Orange County) and SCE are parties to a Power Purchase Agreement, dated July 2, 1992 as amended ("Existing PPA"), which includes, as an Appendix thereto, an Interconnection Facilities Agreement (the "IFA"), pursuant to which, among other things, the Customer and SCE established interconnection arrangements between the Generating Facility and the Distribution System.

**WHEREAS**, Customer and SCE have agreed to enter into this Agreement for the purpose of (i) replacing the existing IFA which is under the jurisdiction of the CPUC, and (ii) establishing interconnection arrangements pursuant to Rule 21.

**WHEREAS**, Generating Facility is described below in Section 1 of this Attachment A-1 to this Agreement and includes: (i) an existing 12,000 kW interconnected generation resource which was not required to submit an Interconnection Request pursuant to Rule 21 and did not participate in the Fast Track Process, Independent Study Process, Cluster Study Process or Transmission Cluster Process and was not subject to the related Interconnection Studies, and (ii) a new 4,000 kW generation resource which submitted a new Interconnection Request pursuant to Rule 21 and participated in the Fast Track Process to complete the related Interconnection Studies.

**WHEREAS**, the existing PPA, including the IFA will terminate upon the effective date of this Agreement.

**WHEREAS**, in the FFOA included as Attachment B to this Agreement, Existing Interconnection Facilities ("Existing") installed pursuant to the IFA are identified as well as the Customer's related cost responsibility. New Interconnection Facilities, Distribution Upgrades, and Network Upgrades, as applicable, ("New") have also been identified in the FFOA included as Attachment B to this Agreement consistent with current interconnection standards pursuant to the requirements of this Agreement.

**WHEREAS**, New Interconnection Facilities described in the FFOA included as Attachment B to this Agreement are based on SCE's preliminary engineering and design. Such descriptions are subject to modification to reflect the actual facilities constructed and installed following SCE's final engineering and design, identification of field conditions, and compliance with applicable environmental and permitting requirements.

**NOW THEREFORE**, the Parties agree to the additional terms of this Agreement as follows:

Equipment, including the Generating Facility, Interconnection Facilities, and metering equipment, shall be itemized and identified as being owned by the Customer or SCE. SCE will provide a best estimate itemized cost, including a cost estimate pursuant to the Cost Envelope Option provisions of Rule 21, Section F.7, if applicable, including overheads and any applicable ITCC, of its Interconnection Facilities



**SOUTHERN CALIFORNIA EDISON COMPANY  
NET BILLING TARIFF OR NET ENERGY METERING AND RENEWABLE  
ELECTRICAL GENERATING FACILITY SIZED GREATER THAN ONE  
MEGAWATT INTERCONNECTION AGREEMENT  
ORANGE COUNTY SANITATION DISTRICT  
NST-497000**

and metering equipment, and a best estimate itemized cost of the annual operation and maintenance expenses associated with its Interconnection Facilities and metering equipment.

**1. Description of Generating Facility:**

All equipment and facilities comprising the Customer's 16,000 kW (16,000 kW CEC-AC) digester gas fueled cogeneration generating facility located at 22212 Brookhurst St, Huntington Beach, CA, 92646, as disclosed by the Customer in its Application, which includes:

- a. **Existing Generators:** a 12,000 net kW (12,000 gross kW) digester gas fueled cogeneration system which consists of (i) four (4) Ideal Electric Company SAMB Frame M-9-33 internal combustion engine each rated at 3,000 net kW (3,000 gross kW) for a total maximum output of 12,000 kW, (ii) the associated infrastructure, (iii) power factor correction equipment, as necessary, (iv) meters and metering equipment, and (v) appurtenant equipment.
- b. **New Generators:** a 4,000 net kW (4,000 gross kW) digester gas fueled cogeneration system which consists of (i) one (1) Ideal Electric Company SAMB Frame M-9-33 internal combustion engine rated at 3,000 net kW (3,000 gross kW), one (1) Kato Engineering A251460000 steam turbine synchronous generator rated at 1,000 net kW (1,000 gross kW) for a total maximum output of 4,000 kW, (ii) the associated infrastructure, (iii) power factor correction equipment, as necessary, (iv) meters and metering equipment, and (v) appurtenant equipment.

**2. Description and Costs of Interconnection Facilities and Metering Equipment:**

See FFOA included as Attachment B to this Agreement.

**3. Single-Line Diagram:**

See FFOA included as Attachment B to this Agreement.

**Attachment A-2**

**Description of Distribution and/or Network Upgrades and Cost Responsibility**

SCE shall describe the Distribution and/or Network Upgrades and provide an itemized best estimate of the cost, including a cost estimate pursuant to the Cost Envelope Option provisions of Rule 21, Section F.7, if applicable, including overheads and any applicable ITCC, of the Distribution and/or Network Upgrades and annual operation and maintenance expenses associated with such Distribution and/or Network Upgrades. SCE shall functionalize the upgrade costs and annual expenses as either transmission or distribution related.

**1. Description of Distribution Upgrades and Network Upgrades and Cost Responsibility:**

See FFOA included as Attachment B to this Agreement.

REFERENCE COPY

**SOUTHERN CALIFORNIA EDISON COMPANY  
NET BILLING TARIFF OR NET ENERGY METERING AND RENEWABLE  
ELECTRICAL GENERATING FACILITY SIZED GREATER THAN ONE  
MEGAWATT INTERCONNECTION AGREEMENT  
ORANGE COUNTY SANITATION DISTRICT  
NST-497000**

**Attachment A-3**

**Milestones**

In-Service Date: See Milestone 10 below

Critical milestones and responsibility as agreed to by the Parties:

	<b>Milestone</b>	<b>Date</b>	<b>Responsible Party</b>
(1)	Provide project payment(s) to SCE in accordance with Section 3.1 of Attachment A of this Agreement	<u>Existing</u> Deemed to have been completed under the IFA  <u>New</u> Within twenty (20) Business Days of the effective date of this Agreement	Customer
(2)	Submit complete design package <sup>2</sup> as requested by SCE	<u>Existing</u> Deemed to have been completed under the IFA  <u>New</u> Within twenty (20) Business Days of the effective date of this Agreement	Customer
(3)	Review and approval of Customer's design package <sup>3</sup>	<u>Existing</u> Deemed to have been completed under the IFA  <u>New</u> Within five (5) Business Days of completion of Milestone (2)	SCE
(4)	Draft of SCE's preliminary design for Interconnection Facilities and Distribution Upgrades	<u>Existing</u> Deemed to have been completed under the IFA  <u>New</u> Within sixty (60) Business Days from approval of Milestone (3)	SCE

<sup>2</sup> See the Generating Facility's interconnection study report dated April 3, 2024 for design package requirements.

<sup>3</sup> Additional time will be required between Milestone (2) and (3) if the design package is not deemed complete and requires additional information.

**SOUTHERN CALIFORNIA EDISON COMPANY  
NET BILLING TARIFF OR NET ENERGY METERING AND RENEWABLE  
ELECTRICAL GENERATING FACILITY SIZED GREATER THAN ONE  
MEGAWATT INTERCONNECTION AGREEMENT  
ORANGE COUNTY SANITATION DISTRICT  
NST-497000**

	<b>Milestone</b>	<b>Date</b>	<b>Responsible Party</b>
(5)	Approve preliminary design for Interconnection Facilities	<u>Existing</u> Deemed to have been completed under the IFA  <u>New</u> Within five (5) Business Days of completion of Milestone (4)	Customer
(6)	Complete final design for Interconnection Facilities	<u>Existing</u> Deemed to have been completed under the IFA  <u>New</u> Within thirty (30) Business Days of completion of Milestone (5)	SCE
(7)	Complete below grade civil work <sup>4</sup> (“Civil Construction” as defined in Section 2 of Attachment A of the FFOA) with SCE oversight and receive SCE inspector release	<u>Existing</u> Deemed to have been completed under the IFA  <u>New</u> Within forty (40) <sup>5</sup> Business Days following completion of Milestone (6)	Customer
(8)	Completion of the construction of the Interconnection Facilities	<u>Existing</u> Deemed to have been completed under the IFA  <u>New</u> Within ninety (90) Business Days following completion of Milestone (7)	SCE
(9)	Submit proof of insurance coverage in accordance with Section 9 of this Agreement	At least ten (10) Business Days prior to the date of Parallel Operation	Customer

<sup>4</sup> Delays in obtaining requisite easements and/or permits and customer delays in constructing all civil work for the underground scope in accordance with SCE Electrical Design Standards will result in additional time required to complete Milestone (8) as completion of this milestone is dependent on completion of all civil work.

<sup>5</sup> Timeline is only an estimate and is dependent upon project design specifications and Customer’s ability to complete.

**SOUTHERN CALIFORNIA EDISON COMPANY  
NET BILLING TARIFF OR NET ENERGY METERING AND RENEWABLE  
ELECTRICAL GENERATING FACILITY SIZED GREATER THAN ONE  
MEGAWATT INTERCONNECTION AGREEMENT  
ORANGE COUNTY SANITATION DISTRICT  
NST-497000**

	<b>Milestone</b>	<b>Date</b>	<b>Responsible Party</b>
(10)	In-Service Date <sup>6</sup> and schedule commissioning testing	<u>Existing</u> Deemed to have been completed under the IFA  <u>New</u> Following completion of Milestone (8) (estimated In-Service Date by 9/19/2025) <sup>6</sup>	Customer
(11)	Testing of SCE's Interconnection Facilities and testing of the Customer's Interconnection Facilities and Generating Facility in accordance with Rule 21 Sections F.5 and L.5	<u>Existing</u> Deemed to have been completed under the IFA  <u>New</u> Within ten (10) Business Days following completion of Milestone 10.	Customer and SCE
(12)	SCE's written authorization for Parallel Operation of the Generating Facility in compliance with Rule 21 Section F.5 (b)	Within five (5) Business Days after the provision of any required documentation and satisfaction of any inspections and testing requirements in Rule 21 and compliance with the terms of this Agreement	SCE

Agreed to by:

For SCE: \_\_\_\_\_ Date: \_\_\_\_\_  
                  Marcus Lotto

For the Customer: \_\_\_\_\_ Date: \_\_\_\_\_  
                                  Ryan P. Gallagher

<sup>6</sup> Customer understands and acknowledges that such timeline is only an estimate and that equipment and material lead times, labor availability, outage coordination, regulatory approvals, right-of-way negotiations, or other unforeseen events, or [ESR](#) violations could delay the actual in-service dates of SCE's Interconnection Facilities and Distribution Upgrades beyond those specified. SCE shall use Reasonable Efforts to complete engineering, procurement and installation of the Distribution Provider's Interconnection Facilities and Distribution Upgrades by the dates set forth above.





**SOUTHERN CALIFORNIA EDISON COMPANY  
NET BILLING TARIFF OR NET ENERGY METERING AND RENEWABLE  
ELECTRICAL GENERATING FACILITY SIZED GREATER THAN ONE  
MEGAWATT INTERCONNECTION AGREEMENT  
ORANGE COUNTY SANITATION DISTRICT  
NST-497000**

**Attachment B  
(If Applicable)**

**FACILITIES FINANCING AND OWNERSHIP AGREEMENT  
(Provided by SCE)**

REFERENCE COPY

**1. PARTIES:**

The Parties to this Facilities Financing and Ownership Agreement (FFOA) are, Orange County Sanitation District (Customer), and Southern California Edison Company, (SCE). Customer and SCE are sometimes referred to herein individually as "Party," and collectively as "Parties."

**2. RECITALS:**

- 2.1 Customer has applied to interconnect a 16,000 kW (Gross Nameplate capacity) Generating Facility that will be operated in parallel with SCE's Distribution System. Said Generating Facility is described in Section 2 and Attachment A-1 of the Generating Facility Interconnection Agreement ("GFIA") between the Parties to which this FFOA is attached. SCE has assigned the Generating Facility identification number NST-497000 to this facility.
- 2.2 The electrical facilities installed, owned, operated and maintained by SCE described in Attachment A, attached hereto, are required to interconnect Customer's Generating Facility to the SCE Distribution System pursuant to SCE's Rule 21. Such electrical facilities may include Interconnection Facilities, Distribution Upgrades and Network Upgrades.
- 2.3 Pursuant to SCE's Rule 21 all or a portion of the Interconnection Facilities, Distribution Upgrades and Network Upgrades are provided at the Customer's expense by SCE as "Added Facilities" as defined in SCE's Rule 2.H.

**3. AGREEMENT:**

The Parties agree as follows:

- 3.1 Unless otherwise defined herein, initially capitalized terms shall have the same meanings as defined in the GFIA or Section C of SCE's Rule 21. If any term is defined in both the GFIA and Rule 21, the definition in Rule 21 shall prevail.
- 3.2 The Parties agree to the arrangements as indicated in this Section 3.2 for the financing, design, installation, operation, maintenance, and ownership of the Interconnection Facilities, Distribution Upgrades and Network Upgrades described in Attachment A, attached hereto.
  - 3.2.1 SCE, at Customer's expense, shall install, own, operate, and maintain the Interconnection Facilities, Distribution Upgrades and Network Upgrades described as "Customer-Financed Added Facilities" in Attachment A, attached hereto.
  - 3.2.2 Customer shall finance, install, own, operate, and maintain the Interconnection Facilities described as "Customer-Constructed and Owned Interconnection Facilities" in Attachment A, attached hereto.

**4. TERM AND TERMINATION:**

- 4.1 This FFOA shall become effective as of the last date entered in Section 11 below. The FFOA shall continue in full force and effect until terminated by (1) either Party on at least thirty (30) days advance written notice or (2) the end of the 20-year term provided under Section 6.3(b) herein or (3) termination of the GFIA to which this FFOA is attached. Upon termination, Customer shall pay all costs and charges incurred to the date of termination pursuant to Section 8.9 herein, including but not limited to charges for engineering, surveying, right-of-way and easement acquisition expenses or any other expense incurred by SCE for the Customer, even if the Interconnection Facilities, Distribution Upgrades and Network Upgrades have not been installed.



4.2 Customer agrees to utilize the Interconnection Facilities, Distribution Upgrades and Network Upgrades described in Attachment A, attached hereto, in accordance with Prudent Electrical Practices. If Customer fails to so utilize said Interconnection Facilities, Distribution Upgrades and Network Upgrades, SCE may terminate this FFOA, remove the Interconnection Facilities, Distribution Upgrades and Network Upgrades, and Customer shall be subject to the Termination Charge pursuant to Section 8.9 herein.

**5. PROJECT DEVELOPMENT MILESTONES:**

Project development milestones, if applicable, are identified in Attachment A-3 of the GFIA.

**6. INTERCONNECTION FACILITIES, DISTRIBUTION UPGRADES AND NETWORK UPGRADES PROVIDED AS CUSTOMER-FINANCED ADDED FACILITIES:**

The following shall apply for that portion of the Interconnection Facilities, Distribution Upgrades and Network Upgrades specified in Attachment A, attached hereto, as "Customer-Financed Added Facilities."

6.1 SCE shall, pursuant to SCE's Rule 21, engineer, design, procure equipment and materials, construct, install, own, operate, and maintain the Customer-Financed Added Facilities.

6.2 Customer shall pay to SCE in advance of construction, the estimated total Added Facilities Investment of said Customer-Financed Added Facilities, as set forth in Attachment A, attached hereto, as may be revised pursuant to Sections 8.2 and/or 8.3, herein. If applicable, said cost shall include the estimated Income Tax Component of Contributions (ITCC), pursuant to SCE's Preliminary Statement Part M as filed with the Commission and as may be revised from time to time.

6.3 In addition to the payment required under Section 6.2 herein, Customer shall pay to SCE an ownership charge determined as the product of (1) the total Added Facilities Investment in Customer-Financed Added Facilities as set forth in Attachment A, attached hereto, as may be revised pursuant to Sections 8.2 and/or 8.3 herein, and (2) the rate established for the replacement coverage option for "Customer-Financed Added Facilities" agreed to by the Parties as reflected in this Section 6.3 as set forth in SCE's Rule 2.H as filed with the Commission and as may be revised from time to time. Whenever Added Facilities are replaced, the Added Facilities Investment amount used as the basis for determining the ownership charge Customer pays SCE shall be subject to the conditions set forth in Section 8.6 or 8.7 herein. The replacement coverage option for Customer-Financed Added Facilities is as follows:

Existing:

(a) Replacement Coverage into Perpetuity

Under this option, Customer shall pay to SCE, at SCE's sole option, either:

(1) A Monthly Charge determined by SCE based upon an initial monthly rate of **0.39** % times the total Added Facilities Investment amount; or,

N/A (2) A One-Time Payment determined by SCE representing the present value of the sum of the Monthly Charges for the total Added Facilities Investment amount.

N/A (b) Replacement Coverage with 20-Year Term

Under this Option, for a term of 20 years beginning with the date said Added Facilities are first made available for Customer's use, Customer shall pay to SCE a Monthly Charge determined by SCE based upon an initial monthly rate

of 0.32 % times the total Added Facilities Investment amount. At the end of the 20-year term, this FFOA shall terminate. If the Customer elects to continue to utilize the Added Facilities past the term of this FFOA, Customer and SCE must execute a new Added Facilities agreement without replacement coverage or with replacement coverage in perpetuity pursuant to the provision in SCE's Rule 2 Section H.2.f.(3).

N/A (c) Without Replacement Coverage

Under this option, Customer shall pay SCE a Monthly Charge determined by SCE based upon an initial monthly rate of 0.29 % times the total Added Facilities Investment amount.

New:

N/A (a) Replacement Coverage into Perpetuity

Under this option, Customer shall pay to SCE, at SCE's sole option, either:

N/A (1) A Monthly Charge determined by SCE based upon an initial monthly rate of 0.39 % times the total Added Facilities Investment amount; or,

N/A (2) A One-Time Payment determined by SCE representing the present value of the sum of the Monthly Charges for the total Added Facilities Investment amount.

N/A (b) Replacement Coverage with 20-Year Term

Under this Option, for a term of 20 years beginning with the date said Added Facilities are first made available for Customer's use, Customer shall pay to SCE a Monthly Charge determined by SCE based upon an initial monthly rate of 0.32 % times the total Added Facilities Investment amount. At the end of the 20-year term, this FFOA shall terminate. If the Customer elects to continue to utilize the Added Facilities past the term of this FFOA, Customer and SCE must execute a new Added Facilities agreement without replacement coverage or with replacement coverage in perpetuity pursuant to the provision in SCE's Rule 2 Section H.2.f.(3).

N/A (c) Without Replacement Coverage

Under this option, Customer shall pay SCE a Monthly Charge determined by SCE based upon an initial monthly rate of 0.29 % times the total Added Facilities Investment amount.

**7. INTERCONNECTION FACILITIES PROVIDED AS CUSTOMER-CONSTRUCTED AND OWNED INTERCONNECTION FACILITIES:**

For that portion of the Interconnection Facilities specified in Attachment A, attached hereto, as "Customer-Constructed and Owned Interconnection Facilities", the Customer is subject to the following:

- 7.1 At Customer's expense, Customer shall finance, engineer, design, acquire equipment and materials, construct, obtain rights-of-way as necessary, install, own, lease or rent, operate, and maintain the Customer-Constructed and Owned Interconnection Facilities. The Customer-Constructed and Owned Interconnection Facilities shall be engineered, designed and constructed to be compatible with SCE's Interconnection Facilities, Distribution Upgrades and Network Upgrades, and in accordance with SCE's Rule 21, as applicable.

- 7.2 SCE shall, at Customer's expense, review Customer's design and require modifications that SCE reasonably determines necessary to assure compatibility with SCE's electrical system and assure SCE system integrity.
- 7.3 Customer shall notify SCE at least thirty (30) days prior to the Parallel Operation of Customer's Generating Facility and SCE shall have the right to inspect the Customer-Constructed and Owned Interconnection Facilities and shall notify Customer of any deficiencies within five (5) days after inspection. Customer must correct any deficiencies prior to Parallel Operation of the Generating Facility.

**8. INTERCONNECTION FACILITIES, DISTRIBUTION UPGRADES AND NETWORK UPGRADES BILLING:**

- 8.1 Customer shall pay to SCE in advance of any construction by SCE, any one-time costs (including, when applicable, the ITCC) to rearrange existing facilities and/or to provide facilities normally installed by the Customer as set forth in Attachment A, attached hereto, as "One-Time Costs."
- 8.2 Unless otherwise agreed in writing, the costs and charges paid by Customer pursuant to Sections 6.2, 6.3, 7.2, 8.1, and 8.9 herein shall initially be based upon estimated costs. When the recorded book costs have been determined by SCE, the costs and charges paid by Customer under this FFOA shall be revised to be based upon such recorded costs and adjusted retroactively to the date when service was first available by means of such Added Facilities. By executing this FFOA, Customer has been informed and understands SCE's determination of recorded book cost may be delayed and that unless otherwise agreed, retroactive adjustments resulting from such determination may occur at anytime during the term of this FFOA. All amounts billed under this FFOA, unless other terms are mutually agreed upon, shall be payable to SCE within thirty (30) days from the date of presentation of a bill. Any credits resulting from such adjustments will, unless other terms are mutually agreed upon, be refunded to Customer.
- 8.3 SCE shall have the right to revise the initial estimated costs and bill Customer using such revised estimated costs during the period preceding determination of the recorded book costs. SCE shall indicate such revisions on Attachment A, attached hereto, or a superseding Attachment A and provide a copy to Customer. SCE shall commence billing the costs and charges paid by Customer pursuant to this FFOA using such revised estimate not earlier than thirty (30) days from the date the revised estimate is provided to Customer.
- 8.4 Whenever the ownership charge is to be paid by Customer as a Monthly Charge pursuant to Section 6.3 herein, the Monthly Charge shall automatically increase or decrease without formal amendment to this FFOA if the Commission subsequently authorizes a higher or lower percentage rate in the calculation of the costs of ownership for Added Facilities as stated in SCE's Rule 2.H, effective with the date of such authorization.
- 8.5 If it becomes necessary for SCE to alter or rearrange the Added Facilities including, but not limited to, the conversion of overhead facilities to underground, Customer shall be notified of such necessity and shall be given the option to either terminate this FFOA in accordance with Sections 4 and 8.9 herein, or to pay to SCE additional amounts consisting of:
  - (a) Revised costs and charges based on the total net additional installed cost of all new and remaining Added Facilities. Such revised costs and charges shall be determined, as applicable, in the same manner as described in Sections 6.2 and 6.3 herein; plus

- (b) An additional payment of ITCC, and/or one-time cost, if any, for any new Added Facilities which shall be determined in the same manner as described in Sections 6.2 and 8.1 herein; plus
  - (c) The cost to remove any portion of the Added Facilities that are no longer necessary because of alteration or rearrangement, such charge is to be determined by SCE in the same manner as described in Section 8.9 herein.
- 8.6 Whenever Added Facilities are replaced due to damage (caused by other than the Customer's intentional or negligent conduct) or equipment failure and replacement coverage is provided pursuant to Sections 6.3(a) or (b) herein, such replacement will be at SCE's expense with no change in the Added Facilities Investment amount.
- 8.7 Whenever Added Facilities are replaced (1) due to damage or equipment failure and replacement coverage is not provided pursuant to Section 6.3(c) herein, or (2) due to Customer's increased load or generation levels, as determined by SCE, or (3) Customer's intentional or negligent conduct, such replacement will be made by SCE at the Customer's expense, including any applicable ITCC. Any additional amounts due to SCE as a result of such replacement shall be payable by the Customer to SCE within thirty (30) days from the date of presentation of a bill. If such replacement results in a change in the Added Facilities Investment, the Monthly Charge will be adjusted based on the revised added investment amount effective with the date the replaced Added Facilities are first available for Customer's use. Except that, where the replacement of Added Facilities is solely required for SCE's operating convenience or necessity or because of damage caused by the sole negligence or willful act of SCE, no increase shall be made in the Added Facilities Investment amount or the Monthly Charge.
- 8.8 Except as otherwise provided in this FFOA, SCE shall have the right to charge Customer under the terms and conditions of this FFOA commencing with the date SCE, in its sole opinion, determines the Added Facilities are available for Customer's use.
- 8.9 Upon discontinuance of the use of any Added Facilities due to termination of service, termination of this FFOA, or otherwise:
  - (a) Customer shall pay to SCE on demand (in addition to all other moneys to which SCE may be legally entitled by virtue of such termination) a Termination Charge defined as the removal cost less the salvage value of the Added Facilities to be removed. Commencing in the sixteenth (16) year after the date service is first rendered by means of said Added Facilities, 20 percent of the Termination Charge shall be subtracted from that charge each year until the total charge is zero.
  - (b) SCE shall be entitled to remove and shall have a reasonable time in which to remove any portion of the Added Facilities located on the Customer's property.
  - (c) SCE may, at its option, alter, rearrange, convey, or retain in place any portion of the Added Facilities located on property other than Customer's property. Where all or any portion of the Added Facilities located on property other than Customer's property are retained in place and used by SCE to provide permanent service to other customers, the facility Termination Charge described in Section 8.9(a), herein, shall be reduced by the recorded installed cost of the retained facilities.
- 8.10 Customer shall not be required to pay the Termination Charge specified in Section 8.9, herein if termination of the use of the Added Facilities is caused solely by SCE. Termination pursuant to Section 4.2 herein or Section 15.2 of the GFIA shall be deemed not to have been caused solely by SCE.

- 8.11 Should any amount billed pursuant to this FFOA not be paid by Customer, SCE shall at any time be entitled to collect such amounts through an offset against any amount SCE may owe to Customer.

**9. GENERAL PROVISIONS:**

- 9.1 Unless otherwise provided for in this FFOA, Interconnection Facilities connected to SCE's side of the Point of Common Coupling, Distribution Upgrades and Network Upgrades shall be provided, installed, owned, and maintained by SCE at Customer's expense in accordance with SCE's Rule 21.
- 9.2 SCE shall not be obligated to begin construction of Added Facilities prior to Customer's payment of all moneys due as described in Sections 6.2, 6.3, 8.1, and 8.9 herein.
- 9.3 Where it is necessary to install Added Facilities on Customer's property, Customer hereby grants to SCE (a) the right to make such installation on Customer's property including installation of a line extension along the shortest practical route thereon and (b) the right of ingress to and egress from Customer's property as determined by SCE in its sole discretion for any purpose connected with the operation and maintenance of the Added Facilities. Customer shall provide rights-of-way or easements of sufficient space to provide legal clearance from all structures now or hereafter erected on Customer's property for any facilities of SCE.
- 9.4 Where formal rights-of-way or easements are required in, on, under, or over Customer's property or the property of others for the installation of the Added Facilities, SCE shall not be obligated to install the Added Facilities unless and until any necessary permanent rights-of-way or easements, satisfactory to SCE, are granted without cost to SCE. Upon termination of this FFOA in accordance with Section 4, SCE shall quitclaim all easements and rights of way in, on, under, and over Customer's property, which are, as determined by SCE in its sole discretion, no longer required by SCE due to the removal of its Added Facilities.
- 9.5 SCE shall not be responsible for any delay in completion of the installation of the Added Facilities including, but not limited to, delays resulting from shortage of labor or materials, strike, labor disturbances, war, riot, weather conditions, governmental rule, regulation, or order, including orders or judgments of any court or commission, delay in obtaining necessary rights-of-way and easements, act of God, or any other cause or condition beyond control of SCE. SCE shall have the right in the event it is unable to obtain materials or labor for all of its construction requirements, to allocate materials and labor to construction projects which it deems, in its sole discretion, most important to serve the needs of its customers, and any delay in construction hereunder resulting from such allocation shall be deemed to be a cause beyond SCE's control.
- 9.6 SCE shall not be liable for any loss, damage, or injury arising from SCE's installation, operation, maintenance, or control of the Added Facilities, unless such loss, damage, or injury results from SCE's sole negligence, and, in no event, shall SCE be liable for loss of profits, revenues, or other consequential damages. No adjustment shall be made to reduce billings if damages to, or malfunction of the Added Facilities results from any cause other than the negligence or willful act of SCE.
- 9.7 Added Facilities provided hereunder shall at all times remain the property of SCE.
- 9.8 This FFOA supplements the appropriate application and contract(s) for electric service presently in effect between the Parties.
- 9.9 Customer may assign this FFOA only with SCE's written consent. Such consent shall not be unreasonably withheld. Such assignment shall be deemed to include, unless

otherwise specified therein, all of Customer's rights to any refunds, which might become due upon discontinuance of the use of any Added Facilities.

**10. GOVERNING LAW**

This FFOA shall be interpreted, governed, and construed under the laws of the State of California as if executed and to be performed wholly within the State of California and shall, to the extent provided by law, at all times be subject to applicable tariff rules and modification of such rules as directed by the Commission in the exercise of its jurisdiction.

**11. SIGNATURES**

This FFOA may be executed in counterparts, and by Electronic Signature on the part of SCE and/or the Customer, and copies of a Party's signed signature page may be transmitted to the other Party by facsimile or other electronic means. Copies of the signature page so transmitted may be used for the purpose of enforcing the terms of this FFOA as though they were originals and will not be made inadmissible in any legal or regulatory proceeding concerning this FFOA on the basis of the Best Evidence Rule or similar rule of admissibility.

IN WITNESS WHEREOF, the Parties hereto have caused this FFOA to be executed by their duly authorized representatives. This FFOA is effective as provided in Section 4.1 above.

**ORANGE COUNTY SANITATION DISTRICT**

**SOUTHERN CALIFORNIA  
EDISON COMPANY**

By: \_\_\_\_\_  
Name:           Ryan P. Gallagher            
Title:           Board Chairman            
\_\_\_\_\_  
Date: \_\_\_\_\_

By: \_\_\_\_\_  
Name:           Marcus Lotto            
Title:           Senior Manager, Grid  
          Interconnection & Contract  
          Development            
\_\_\_\_\_  
Date: \_\_\_\_\_

**ATTEST:**

By: \_\_\_\_\_  
Name:           Kelly A. Lore, MMC            
Title:           Clerk of the Board            
Date: \_\_\_\_\_

ATTACHMENT B  
FACILITIES FINANCING AND OWNERSHIP AGREEMENT  
SOUTHERN CALIFORNIA EDISON COMPANY  
ORANGE COUNTY SANITATION DISTRICT  
NST-497000

---

**APPROVED AS TO FORM:**

By: \_\_\_\_\_

Name: Scott C. Smith

Title: General Counsel

Date: \_\_\_\_\_

REFERENCE COPY

ATTACHMENT A TO ATTACHMENT B  
 FACILITIES FINANCING AND OWNERSHIP AGREEMENT  
 SOUTHERN CALIFORNIA EDISON COMPANY  
 ORANGE COUNTY SANITATION DISTRICT  
 NST-497000

1. **Added Facilities Investment for Customer- Financed Facilities (Existing – Installed Pursuant to the IFA)**  
 (Provided per Section 3.2.1)

	<b>Component</b>	<b>Original Estimate</b>	<b>Revised Estimate</b>	<b>Recorded Cost</b>
A.	<b>Interconnection Facilities*</b>			
	- Huntington Beach Generating Station – Install telesync circuit equipment			\$11,486.84
	- Huntington Beach-La Fayette-Plant 66 kV transmission line – Install three spans of 954 KCMIL SAC conductor and two KPF switches			\$50,205.47
	- Ellis Substation – Install telesync circuit equipment			\$9,809.84
	- Ellis Substation – Engineer and install a telesync transmitter			\$36,583.92
	Orcogen Substation – Install telesync circuit equipment			\$6,589.01
	Orcogen Substation – Construct a 22.4 MVA 66/12 kV customer substation with 66 kV circuit breaker, HCB pilot wire protection and metering			\$613,048.06
	Orcogen Substation – Engineer and construct the required additions to equip the substation as a cogen interface facility			\$558,814.75
	Orcogen Substation – Install terminal blocks in communication terminal pole to provide pilot wire circuits			\$3,352.01
	Huntington Beach Generating Station – Install 12,000 feet of 12/19 cable on existing route and on 5,000 feet of new messenger			\$19,347.13
B.	<b>Total Added Facilities Investment</b>			<b>\$1,309,237.03</b>
C.	<b>Income Tax Component of Contribution (ITCC)</b>  (B x 24%) (eff. 1/1/2018)			Not Applicable.
D.	<b>One-Time Costs</b> - None.			\$0.00
E.	Customer shall pay to SCE a <b>Monthly Charge</b> determined by SCE based upon an initial monthly rate of <b>0.39%</b> times the Added Facilities Investment amount shown in Row B. above pursuant to Section 6.3 of this FFOA. (((\$1,309,237.03) x 0.39%)			\$5,106.02**



ATTACHMENT A TO ATTACHMENT B  
 FACILITIES FINANCING AND OWNERSHIP AGREEMENT  
 SOUTHERN CALIFORNIA EDISON COMPANY  
 ORANGE COUNTY SANITATION DISTRICT  
 NST-497000

F.	<b>Total Amount to be Advanced by Customer (B.+ C.+ D.)</b>			Not Applicable.
----	---	--	--	-----------------

\*Note: The Interconnection Facilities described in Item A above were installed pursuant to the IFA.

\*\*Note: The Monthly Charge of \$5,106.02 will commence upon the effective date of this Agreement and FFOA.

**1.a. Added Facilities Investment for Customer- Financed Facilities (New – Installed Pursuant to this Agreement, FFOA)**  
 (Provided per Section 3.2.1)

	Component	Original Estimate	Revised Estimate	Recorded Cost
A.	<b>Interconnection Facilities</b> - None.	\$0.00		
B.	<b>Total Added Facilities Investment</b>	<b>\$0.00</b>		
C.	<b>Income Tax Component of Contribution (ITCC)</b>  (B x 24%) (eff. 1/1/2018)	\$0.00		
D.	<b>One-Time Costs</b> - Protection Coordination	\$3,500.00		
E.	Customer shall pay to SCE a <b>Monthly Charge</b> determined by SCE based upon an initial monthly rate of <b>N/A%</b> times the Added Facilities Investment amount shown in Row B. above pursuant to Section 6.3 of this FFOA. (( $\$0.00$ ) x N/A%)	\$0.00		
F.	<b>Total Amount to be Advanced by Customer (B.+ C.+ D.)</b>	<b>\$3,500.00</b>		

**2. Description of Customer - Constructed and Owned Facilities** (Provided per Section 3.2.2)

	Interconnection Facilities Component
a.	All generating unit protective relays, controls and switchgear in compliance with SCE's Rule 21 and Electrical Service Requirements (ESR).
b.	If applicable, Customer is responsible to procure and construct underground duct banks and related structures required for the Customer-Financed Added Facilities ("Civil Construction") in accordance with specifications and designs provided by SCE. SCE may subsequently determine that the Civil Construction, or a portion thereof, may need to be



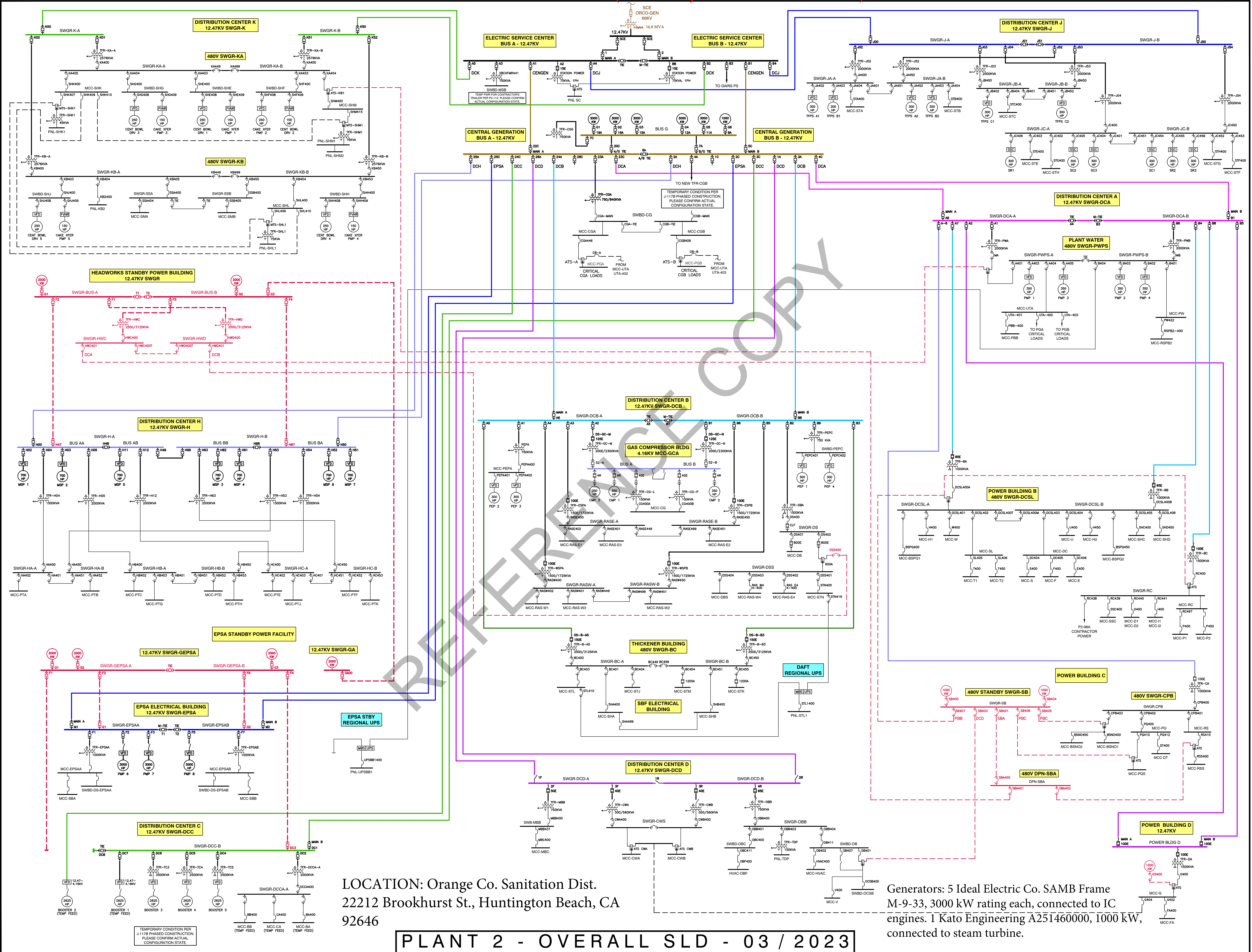

LOCATION: Orange Co. Sanitation Dist.  
 2212 Brookhurst St., Huntington Beach, CA  
 92646

Generators: 5 Ideal Electric Co. SAMB Frame  
 M-9-33, 3000 kW rating each, connected to IC  
 engines. 1 Kato Engineering A251460000, 1000 kW,  
 connected to steam turbine.