

GENERAL SERVICES CONTRACT
Installation and Disposal of Activated Carbon for P1 & P2 Co-Gen Facilities
Specification No. S-2022-1289BD

This GENERAL SERVICES CONTRACT (hereinafter referred to as "Contract"), is made and entered into as of the date fully executed below, by and between Orange County Sanitation District (hereinafter referred to as "OC San") and Carbon Bulk Sales LLC (hereinafter referred to as "Contractor"), and collectively referred to herein as the "Parties."

RECITALS

WHEREAS, OC San desires the Installation and Disposal of Activated Carbon for P1 & P2 Co-Gen Facilities as described in Exhibit "A" attached hereto and incorporated herein by this reference ("Services"); and

WHEREAS, Contractor is qualified to perform the Services by virtue of experience, training, and expertise; and

WHEREAS, OC San desires to engage Contractor to render the Services as provided herein; and

WHEREAS, OC San selected Contractor to perform the Services in accordance with Ordinance No. OC SAN-56; and

WHEREAS, on June 22, 2022, OC San's Board of Directors, by minute order, authorized execution of this Contract.

NOW, THEREFORE, in consideration of the above recitals and the mutual promises and benefits specified below, the Parties agree as follows:

1. General.

1.1 This Contract and all exhibits hereto are made by OC San and the Contractor.

1.2 The following exhibits, in order of precedence, are incorporated by reference and made part of this Contract.

Exhibit "A" – Scope of Work

Exhibit "B" – Bid

Exhibit "C" – Determined Insurance Requirement Form

Exhibit "D" – Contractor Safety Standards

Exhibit "E" – Human Resources Policies

1.3 In the event of any conflict or inconsistency between the provisions of this Contract and any of the provisions of the exhibits hereto, the provisions in the Contract shall control and thereafter the provisions in the document highest in precedence shall be controlling.

1.4 Except as expressly provided otherwise, OC San accepts no liability for any expenses, losses, or actions incurred or undertaken by Contractor as a result of work performed in anticipation of purchases of the Services by OC San.

1.5 Work Hours: All work shall be scheduled Monday through Thursday, between the hours of 7:00 a.m. and 4:00 p.m.

- 1.6 Days: Shall mean calendar days, unless otherwise noted.
- 1.7 OC San holidays (non-working days) are as follows: New Year's Day, Lincoln's Birthday, Presidents' Day, Memorial Day, Independence Day, Labor Day, Veterans Day, Thanksgiving Day, Day after Thanksgiving, Christmas Eve, and Christmas Day.
- 1.8 The provisions of this Contract may be amended or waived only by an amendment executed by authorized representatives of both Parties.
- 1.9 The various headings in this Contract are inserted for convenience only and shall not affect the meaning or interpretation of this Contract or any paragraph or provision hereof.

2. Scope of Work.

- 2.1 Contractor shall perform the Services identified in Exhibit "A" in accordance with generally accepted industry and professional standards.
- 2.2 Modifications to Scope of Work. OC San shall have the right to modify the Scope of Work at any time. All modifications must be made by an amendment signed by both Parties.
- 2.3 Product Availability. In the event the specified product becomes unavailable for any reason, including but not limited to supply chain issues, OC San reserves the right to negotiate pricing with the Contractor, for a substitute product acceptable to OC San.
- 2.4 Familiarity with Work. By executing this Contract, Contractor warrants that: (a) it has investigated the work to be performed; and (b) it understands the facilities, difficulties, and restrictions of the work under this Contract. Should Contractor discover any latent or unknown condition materially differing from those inherent in the work or as represented by OC San, it shall immediately inform OC San of this and shall not proceed, except at Contractor's risk, until written instructions are received from OC San.
- 2.5 Performance. Time is of the essence in the performance of the provisions hereof.

3. Contract Term.

- 3.1 The term of this Contract shall be for one (1) year commencing on July 1, 2022 and continuing through June 30, 2023.
- 3.2 Renewals. At its sole discretion, OC San may exercise the option to renew this Contract for up to four (4) one-year periods. This Contract may be renewed by an OC San Purchase Order. OC San shall have no obligation to renew the Contract nor to give a reason if it elects not to renew it.
- 3.3 Extensions. The term of this Contract may be extended only by an amendment signed by both Parties.

4. Compensation.

- 4.1 As compensation for the Services provided under this Contract, OC San shall pay Contractor a total amount not to exceed Four Hundred Twenty Thousand, Nine Hundred Seventy-two Dollars (\$420,972.00).
- 4.2 Contractor shall provide OC San with all required premiums and/or overtime work at no charge beyond the amount specified above.

5. Payments and Invoicing.

- 5.1 OC San shall pay itemized invoices for work completed in accordance with Exhibit "A", at the prices identified in Exhibit "B", thirty (30) days from receipt of the invoice and after approval by OC San's Project Manager or designee. OC San shall be the determining party, in its sole discretion, as to whether the Services have been satisfactorily completed.
- 5.2 Contractor shall submit its invoices to OC San Accounts Payable by electronic mail to APStaff@OCSan.gov. In the subject line include "INVOICE" and the Purchase Order Number.

6. California Department of Industrial Relations Registration and Record of Wages.

- 6.1 Pursuant to Labor Code sections 1720 et seq., and as specified in Title 8, California Code of Regulations section 16000, prevailing wages are required to be paid for all work under this Contract. It is Contractor's responsibility to interpret and implement any prevailing wage requirements and Contractor agrees to pay any penalty or civil damages resulting from a violation of the prevailing wage laws.
- 6.2 Contractor and its subcontractors shall comply with the registration requirements of Labor Code section 1725.5. Pursuant to Labor Code section 1771.4(a)(1), the work is subject to compliance monitoring and enforcement by the California Department of Industrial Relations (DIR).
- 6.3 Pursuant to Labor Code section 1773.2, a copy of the prevailing rate of per diem wages is available upon request at OC San's principal office. The prevailing rate of per diem wages may also be found at the DIR website for prevailing wage determinations at <http://www.dir.ca.gov/DLSR/PWD>.
- 6.4 Contractor and its subcontractors shall comply with the job site notices posting requirements established by the Labor Commissioner per Title 8, California Code of Regulations section 16461(e). Pursuant to Labor Code sections 1773.2 and 1771.4(a)(2), Contractor shall post a copy of the prevailing rate of per diem wages at the job site.
- 6.5 Contractor and its subcontractors shall maintain accurate payroll records and shall comply with all the provisions of Labor Code section 1776. Contractor and its subcontractors shall submit payroll records to the Labor Commissioner pursuant to Labor Code section 1771.4(a)(3). Pursuant to Labor Code section 1776, the Contractor and its subcontractors shall furnish a copy of all certified payroll records to OC San and/or the general public upon request, provided the public request is made through OC San, the Division of Apprenticeship Standards, or the Division of Labor Standards Enforcement of the Department of Industrial Relations. Pursuant to Labor Code section 1776(h), penalties for non-compliance with a request for payroll records may be deducted from progress payments.
 - 6.5.1 As a condition to receiving payments, Contractor agrees to present to OC San, along with any request for payment, all applicable and necessary certified payrolls and other required documents for the period covering such payment request. Pursuant to Title 8, California Code of Regulations section 16463, OC San shall withhold any portion of a payment, up to and including the entire payment amount, until certified payroll forms and any other required documents are properly submitted. In the event certified payroll forms do not comply with the

requirements of Labor Code section 1776, OC San may continue to withhold sufficient funds to cover estimated wages and penalties under the Contract.

6.6 The Contractor and its subcontractors shall comply with Labor Code section 1774 and section 1775. Pursuant to Labor Code section 1775, the Contractor and any of its subcontractors shall forfeit to OC San a penalty of not more than two hundred dollars (\$200) for each calendar day, or portion thereof, for each worker paid less than the prevailing rates as determined by the DIR for the work or craft in which the worker is employed for any work.

6.6.1 In addition to the penalty and pursuant to Labor Code section 1775, the difference between the prevailing wage rates and the amount paid to each worker for each calendar day or portion thereof for which each worker was paid less than the prevailing wage rate shall be paid to each worker by the Contractor or its subcontractor.

6.7 Contractor and its subcontractors shall comply with Labor Code sections 1810 through 1815. Contractor and its subcontractors shall restrict working hours to eight (8) hours per day and forty (40) hours per week, except that work performed in excess of those limits shall be permitted upon compensation for all excess hours worked at not less than one and one-half (1.5) times the basic rate of pay, as provided in Labor Code section 1815. The Contractor shall forfeit, as a penalty to OC San, twenty-five dollars (\$25) per worker per calendar day during which such worker is required or permitted to work more than eight (8) hours in any one calendar day and forty (40) hours in any one calendar week in violation of Labor Code sections 1810 through 1815.

6.8 Contractor and its subcontractors shall comply with Labor Code sections 1777.5, 1777.6, and 1777.7 concerning the employment of apprentices by Contractor or any subcontractor.

6.9 Contractor shall include, at a minimum, a copy of the following provisions in any contract it enters into with any subcontractor: Labor Code sections 1771, 1771.1, 1775, 1776, 1777.5, 1810, 1813, 1815, 1860, and 1861.

6.10 Pursuant to Labor Code sections 1860 and 3700, the Contractor and its subcontractors will be required to secure the payment of compensation to employees. Pursuant to Labor Code section 1861, Contractor, by accepting this contract, certifies that:

“I am aware of the provisions of section 3700 of the Labor Code which require every employer to be insured against liability for workers’ compensation or to undertake self-insurance in accordance with the provisions of that code, and I will comply with such provisions before commencing the performance of the work of this contract.”

Contractor shall ensure that all its contracts with its subcontractors provide the provision above.

7. **Damage to OC San’s Property.** Any of OC San’s property damaged by Contractor, any subcontractor, or by the personnel of either will be subject to repair or replacement by Contractor at no cost to OC San.

8. **Freight (F.O.B. Destination).** Contractor assumes full responsibility for all transportation, transportation scheduling, packing, handling, insurance, and other services associated with delivery of all products deemed necessary under this Contract.
9. **Audit Rights.** Contractor agrees that, during the term of this Contract and for a period of three (3) years after its expiration or termination, OC San shall have access to and the right to examine any directly pertinent books, documents, and records of Contractor relating to the invoices submitted by Contractor pursuant to this Contract.
10. **Contractor Safety Standards and Human Resources Policies.** OC San requires Contractor and its subcontractor(s) to follow and ensure their employees follow all Federal, State, and local regulations as well as Contractor Safety Standards while working at OC San locations. If, during the course of the Contract, it is discovered that Contractor Safety Standards do not comply with Federal, State, or local regulations, the Contractor is required to follow the most stringent regulatory requirement at no additional cost to OC San. Contractor, its subcontractors, and all of their employees shall adhere to the safety requirements in Exhibit "A," all applicable Contractor Safety Standards in Exhibit "D," and the Human Resources Policies in Exhibit "E."
11. **Insurance.** Contractor and all its subcontractors shall purchase and maintain, throughout the term of this Contract and any periods of warranty or extensions, insurance in amounts equal to the requirements set forth in the signed Exhibit "C" – Determined Insurance Requirement Form. Contractor shall not commence work under this Contract until all required insurance is obtained in a form acceptable to OC San, nor shall Contractor allow any subcontractor to commence service pursuant to a subcontract until all insurance required of the subcontractor has been obtained. Failure to obtain and maintain the required insurance coverage shall result in termination of this Contract.
12. **Bonds.** Not used.
13. **Indemnification and Hold Harmless Provision.** Contractor shall assume all responsibility for damages to property and/or injuries to persons, including accidental death, which may arise out of or may be caused by Contractor's Services under this Contract, or by its subcontractor(s), or by anyone directly or indirectly employed by Contractor, and whether such damage or injury shall accrue or be discovered before or after the termination of the Contract. Except as to the sole active negligence of or willful misconduct of OC San, Contractor shall indemnify, protect, defend, and hold harmless OC San, its elected and appointed officials, officers, agents, and employees from and against any and all claims, liabilities, damages, or expenses of any nature, including attorneys' fees: (a) for injury to or death of any person, or damage to property, or interference with the use of property arising out of or in connection with Contractor's performance under the Contract, and/or (b) on account of use of any copyrighted or uncopyrighted material, composition, or process; or any patented or unpatented invention, article, or appliance furnished or used under the Contract, and/or (c) on account of any goods and services provided under this Contract. This indemnification provision shall apply to any acts or omissions, willful misconduct, or negligent misconduct, whether active or passive, on the part of Contractor or anyone employed by or working under Contractor. To the maximum extent permitted by law, Contractor's duty to defend shall apply whether or not such claims, allegations, lawsuits, or proceedings have merit or are meritless; or which involve claims or allegations that any of the parties to be defended were actively, passively, or concurrently negligent; or which otherwise assert that the parties to be defended are responsible, in whole or in part, for any loss, damage, or injury. Contractor agrees to provide this defense

immediately upon written notice from OC San, and with well qualified, adequately insured, and experienced legal counsel acceptable to OC San. This section shall survive the expiration or early termination of the Contract.

14. **Independent Contractor.** The relationship between the Parties hereto is that of an independent contractor and nothing herein shall be deemed to make Contractor an OC San employee. During the performance of this Contract, Contractor and its officers, employees, and agents shall act in an independent capacity and shall not act as OC San's officers, employees, or agents. Contractor and its officers, employees, and agents shall obtain no rights to any benefits which accrue to OC San's employees.
15. **Subcontracting and Assignment.** Contractor shall not delegate any duties nor assign any rights under this Contract without the prior written consent of OC San. Any such attempted delegation or assignment shall be void.
16. **Disclosure.** Contractor agrees not to disclose, to any third party, data or information generated from this Contract without the prior written consent from OC San.
17. **Non-Liability of OC San Officers and Employees.** No officer or employee of OC San shall be personally liable to Contractor, or any successor-in-interest, in the event of any default or breach by OC San, or for any amount which may become due to Contractor or to its successor, or for breach of any obligation under the terms of this Contract.
18. **Third-Party Rights.** Nothing in this Contract shall be construed to give any rights or benefits to anyone other than OC San and Contractor.
19. **Applicable Laws and Regulations.** Contractor shall comply with all applicable Federal, State, and local laws, rules, and regulations. Contractor also agrees to indemnify and hold OC San harmless from any and all damages and liabilities assessed against OC San as a result of Contractor's noncompliance therewith. Any provision required by law to be included herein shall be deemed included as a part of this Contract whether or not specifically included or referenced.
20. **Licenses, Permits, Ordinances, and Regulations.** Contractor represents and warrants to OC San that it has obtained all licenses, permits, qualifications, and approvals of whatever nature that are legally required to provide the Services. Any and all fees required by Federal, State, County, City, and/or municipal laws, codes, and/or tariffs that pertain to the work performed under this Contract will be paid by Contractor.
21. **Regulatory Requirements.** Contractor shall perform all work under this Contract in strict conformance with applicable Federal, State, and local regulatory requirements including, but not limited to, 40 CFR 122, 123, 124, 257, 258, 260, 261, and 503, Title 22, 23, and Water Codes Division 2.
22. **Environmental Compliance.** Contractor shall, at its own cost and expense, comply with all Federal, State, and local environmental laws, regulations, and policies which apply to the Contractor, its subcontractors, and the Services, including, but not limited to, all applicable Federal, State, and local air pollution control laws and regulations.
23. **South Coast Air Quality Management District's Requirements.** It is Contractor's responsibility to ensure that all equipment furnished and installed be in accordance with the

latest rules and regulations of the South Coast Air Quality Management District (SCAQMD). All Contract work practices, which may have associated emissions such as sandblasting, open field spray painting, or demolition of asbestos containing components or structures shall comply with the appropriate rules and regulations of SCAQMD.

- 24. Warranties.** In addition to the warranties stated in Exhibit "A," the following shall apply:
- 24.1 Manufacturer's standard warranty shall apply. All manufacturer warranties shall commence on the date of acceptance by the OC San Project Manager or designee of the work as complete.
- 24.2 Contractor's Warranty (Guarantee): If within a one (1) year period of completion of all work as specified in Exhibit "A," OC San informs Contractor that any portion of the Services provided fails to meet the standards required under this Contract, Contractor shall, within the time agreed to by OC San and Contractor, take all such actions as are necessary to correct or complete the noted deficiency(ies) at Contractor's sole expense.
- 25. Dispute Resolution.**
- 25.1 In the event of a dispute as to the construction or interpretation of this Contract, or any rights or obligations hereunder, the Parties shall first attempt, in good faith, to resolve the dispute by mediation. The Parties shall mutually select a mediator to facilitate the resolution of the dispute. If the Parties are unable to agree on a mediator, the mediation shall be conducted in accordance with the Commercial Mediation Rules of the American Arbitration Agreement, through the alternate dispute resolution procedures of Judicial Arbitration through Mediation Services of Orange County ("JAMS"), or any similar organization or entity conducting an alternate dispute resolution process.
- 25.2 In the event the Parties are unable to timely resolve the dispute through mediation, the issues in dispute shall be submitted to arbitration pursuant to Code of Civil Procedure, Part 3, Title 9, sections 1280 et seq. For such purpose, an agreed arbitrator shall be selected, or in the absence of agreement, each party shall select an arbitrator, and those two (2) arbitrators shall select a third. Discovery may be conducted in connection with the arbitration proceeding pursuant to Code of Civil Procedure section 1283.05. The arbitrator, or three (3) arbitrators acting as a board, shall take such evidence and make such investigation as deemed appropriate and shall render a written decision on the matter in question. The arbitrator shall decide each and every dispute in accordance with the laws of the State of California. The arbitrator's decision and award shall be subject to review for errors of fact or law in the Superior Court for the County of Orange, with a right of appeal from any judgment issued therein.
- 26. Liquidated Damages.** Not used.
- 27. Remedies.** In addition to other remedies available in law or equity, if the Contractor fails to make delivery of the goods or Services or repudiates its obligations under this Contract, or if OC San rejects the goods or Services or revokes acceptance of the goods or Services, OC San may (a) cancel the Contract; (b) recover whatever amount of the purchase price OC San has paid, and/or (c) "cover" by purchasing, or contracting to purchase, substitute goods or services for those due from Contractor. In the event OC San elects to "cover" as described in (c), OC San shall be entitled to recover from Contractor as damages the difference between the cost of the substitute goods or services and the Contract price, together with any incidental or consequential damages.

28. **Force Majeure.** Neither party shall be liable for delays caused by accident, flood, acts of God, fire, labor trouble, war, acts of government, or any other cause beyond its control, but the affected party shall use reasonable efforts to minimize the extent of the delay. Work affected by a force majeure condition may be rescheduled by mutual consent of the Parties.

29. **Termination.**

29.1 OC San reserves the right to terminate this Contract for its convenience, with or without cause, in whole or in part, at any time, by written notice from OC San. Upon receipt of a termination notice, Contractor shall immediately discontinue all work under this Contract (unless the notice directs otherwise). OC San shall thereafter, within thirty (30) days, pay Contractor for work performed (cost and fee) through the date of termination. Contractor expressly waives any claim to receive anticipated profits to be earned during the uncompleted portion of this Contract. Such notice of termination shall terminate this Contract and release OC San from any further fee, cost, or claim hereunder by Contractor other than for work performed through the date of termination.

29.2 OC San reserves the right to terminate this Contract immediately upon OC San's determination that Contractor is not complying with the Scope of Work requirements, if the level of service is inadequate, or for any other default of this Contract.

29.3 OC San may also immediately terminate this Contract for default, in whole or in part, by written notice to Contractor:

- if Contractor becomes insolvent or files a petition under the Bankruptcy Act; or
- if Contractor sells its business; or
- if Contractor breaches any of the terms of this Contract; or
- if the total amount of compensation exceeds the amount authorized under this Contract.

29.4 All OC San's property in the possession or control of Contractor shall be returned by Contractor to OC San on demand or at the expiration or early termination of this Contract, whichever occurs first.

30. **Attorney's Fees.** If any action at law or in equity or if any proceeding in the form of an Alternative Dispute Resolution (ADR) is necessary to enforce or interpret the terms of this Contract, the prevailing party shall be entitled to reasonable attorney's fees, costs, and necessary disbursements in addition to any other relief to which the prevailing party may be entitled.

31. **Waiver.** The waiver by either party of any breach or violation of, or default under, any provision of this Contract shall not be deemed a continuing waiver by such party of any other provision or of any subsequent breach or violation of this Contract or default thereunder. Any breach by Contractor to which OC San does not object shall not operate as a waiver of OC San's rights to seek remedies available to it for any subsequent breach.

32. **Severability.** If any section, subsection, or provision of this Contract; or any agreement or instrument contemplated hereby; or the application of such section, subsection, or provision is held invalid, the remainder of this Contract or instrument in the application of such section, subsection, or provision to persons or circumstances other than those to which it is held invalid, shall not be affected thereby, unless the effect of such invalidity shall be to substantially frustrate the expectations of the Parties.

IN WITNESS WHEREOF, intending to be legally bound, the Parties hereto have caused this Contract to be signed by their duly authorized representatives.

ORANGE COUNTY SANITATION DISTRICT

Dated: _____

By: _____

John B. Withers
Chair, Board of Directors

Dated: _____

By: _____

Kelly A. Lore
Clerk of the Board

Dated: _____

By: _____

Ruth Zintzun
Purchasing & Contracts Manager

CARBON BULK SALES LLC

Dated: _____

By: _____

Print Name and Title of Officer

CMM

Exhibit “A”
SCOPE OF WORK

EXHIBIT A
SCOPE OF WORK
Installation and Disposal of Activated Carbon for P1&P2 Co-Gen Facilities
Specification No. S-2022-1289BD

A. PURPOSE

This scope of work describes the materials, and installation and disposal requirements for one change out of the digester gas fuel filter system media located at the Orange County Sanitation District's (OC San) Plant No. 1 (10844 Ellis Ave. Fountain Valley, CA) & Plant No. 2 (22212 Brookhurst, Huntington Beach, CA). Services are to be performed up to twelve (12) times per year.

Plant No. 1 gas cleaning system consists of two (2) vessels. The vessels normally operate in series (primary vessel and polisher vessel). Plant No. 2 gas cleaning system consists of three (3) vessels. Two vessels normally operate in series (primary vessel and polisher vessel), and the third vessel is a standby vessel. Appendix A includes the system pictures and Appendix B has the system drawings.

B. SCOPE OF WORK

The change out of filter media will occur as soon as possible after contract award. The Contractor shall be responsible for providing a Certificate of Analysis for the carbon prior to installation. The delivery process shall include the following steps:

1. Delivery of the media to the OC San plant
2. Purging the storage vessel with nitrogen prior to opening
3. Removal of the existing spent media with vacuum truck
4. Installation of the new media in order as specified below
5. Resealing of vessel, purging of the vessel with Nitrogen, and checking for leaks
6. Inspect and replace tank gasket, as needed.
7. Testing of the spent media for suitability for transport and disposal (if required by Contractor)
8. Removal and disposal of spent media

The Contractor is required to equip their worksite staff with the following safety equipment:

1. One keyed lock per employee
2. Hard hat
3. Safety Glasses
4. Steel Toed Shoes
5. Hand protection
6. Safety Vest
7. Full Body Harness
8. Proper length Lanyard
9. 4-gas personal monitors

The Contractor is also required to provide the nitrogen required for purging the Carbon vessel, a vacuum truck capable of holding all 9900lbs, a man lift and a

forklift to facilitate the work. The equipment shall be on site prior to the start of work. The Contractor shall coordinate the schedule and the work with OC San and shall make every effort to minimize the total time for the change out.

C. THE ORDER OF INSTALL FOR EACH VESSEL WILL BE AS FOLLOWS:

1. 80, 4mm will be on the bottom of the vessel
2. 70, 4x8 Coconut shell will be in the center of the vessel
3. 70, 4mm will be the top layer of the vessel

D. FILTER MATERIAL FOR EACH VESSEL SHALL BE:

1. 3300 pounds of 4mm pelletized 70 CTC Virgin based Coal based activated carbon (Top)
2. 3300 pounds of 4x8 70 CTC Virgin based Coconut shell activated carbon (Middle)
3. 3300 pounds of 4mm pelletized 80 CTC Virgin based Coal based activated carbon (Bottom)

It shall have the following physical properties:

- | | | |
|--|------------------------------|-----------------|
| 1. Carbon Tetrachloride Active
noted above) | (ASTM D3467) | 70-80% min. (as |
| 2. Density | (ASTM D2854) | 0.5 ± 0.03 g/cc |
| 3. Moisture Content | (ASTM D2867) | 2-5% |
| 4. Ash | (ASTM D2866) | 12% max |
| 5. Hardness | (ASTM D3802) | 87-90 minimum |
| 6. Mesh size | (4mm and 4X8 as noted above) | |

The filter media shall be clean and free from all dirt, wood, plastic particulate matter or foreign substances. The Certificate of Analysis from an independent laboratory indicating above physical properties as well as Material Safety Data Sheet (MSDS) sheet must be submitted with the bill of lading. The Certificate of Analysis shall contain the analysis date, Bill of Lading number, and above properties. The Carbon Tetrachloride Activity Test may be replaced by Butane Activity Test (ASTM D5742) by the certified laboratory. Analysis of product samples and product troubleshooting analysis are the responsibility of the Contractor. OC San reserves the right to verify product quality using the methods above, as needed, at the Contractor's expense.

OC San may reject any delivery of the filter material which does not meet the product specifications. The Contractor shall remove the rejected material immediately following telephone notification. The Contractor shall replace the volume of removed material immediately.

E. STAFF ASSISTANCE

An OC San Project Manager will be assigned to work with the Contractor for this project. All work will be scheduled through the Project Manager or a designee.

Appendix “A”

Plant 1 - Gas Cleaning System



Plant 2 - Gas Cleaning System



Appendix “B”

REVISIONS				
ZONE	REV.	DESCRIPTION	DATE	APPROVED

NOTES:
 1. WEIGHT LISTED IS FULLY LADEN, WITH VESSELS FILLED WITH 9900 LB'S OF SAG MEDIA PER VESSEL
 2. VESSEL GROUNDING LUG LOCATIONS

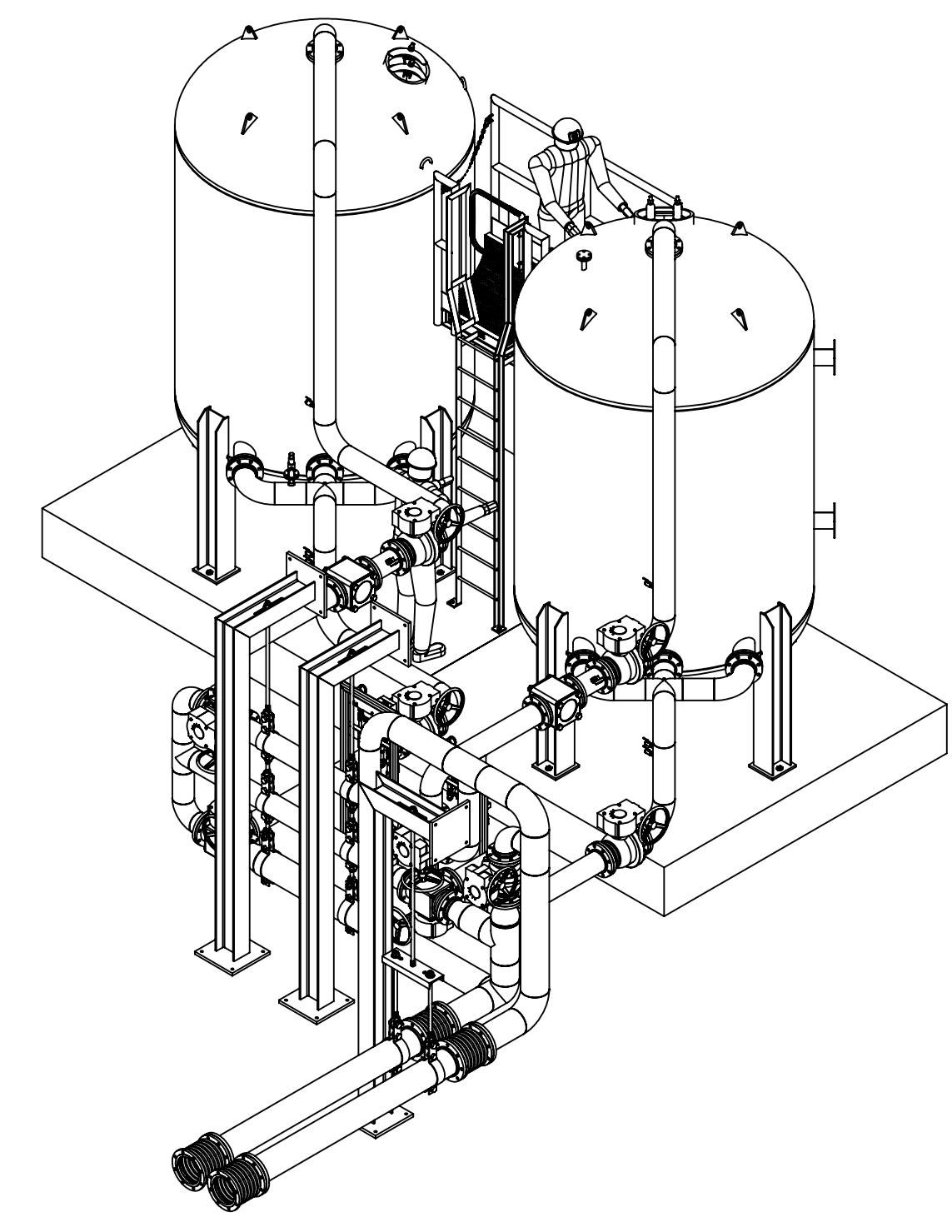
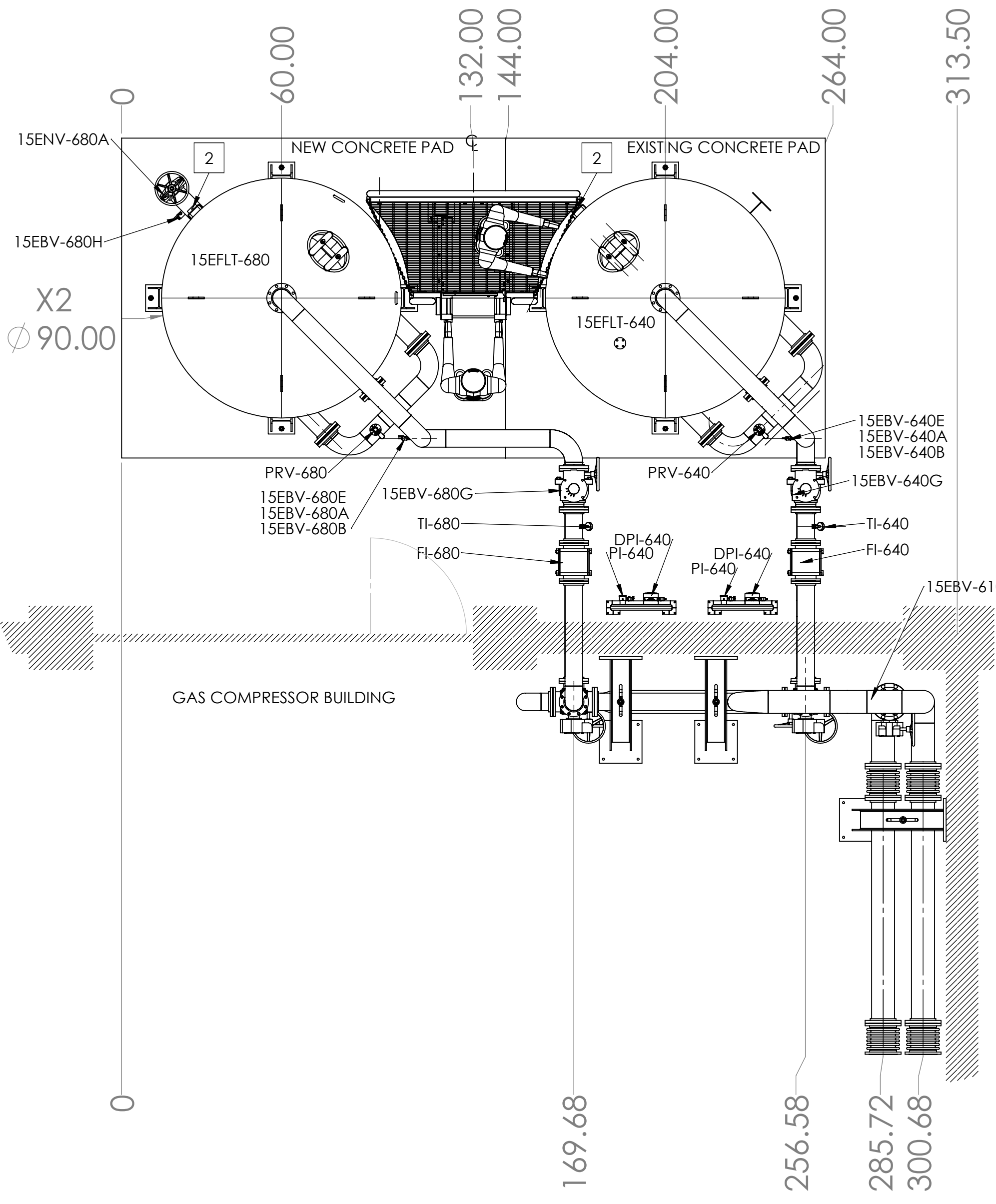
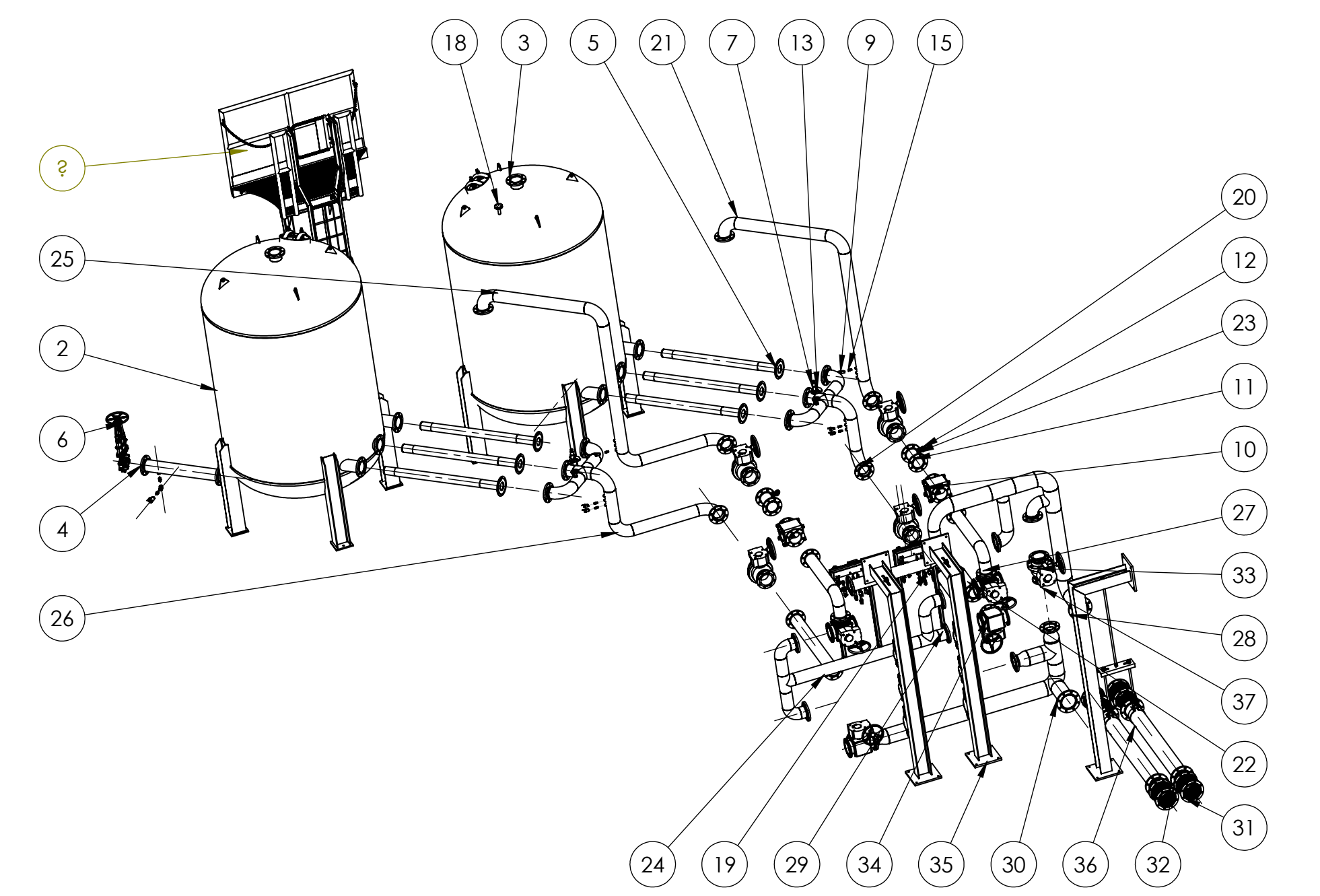
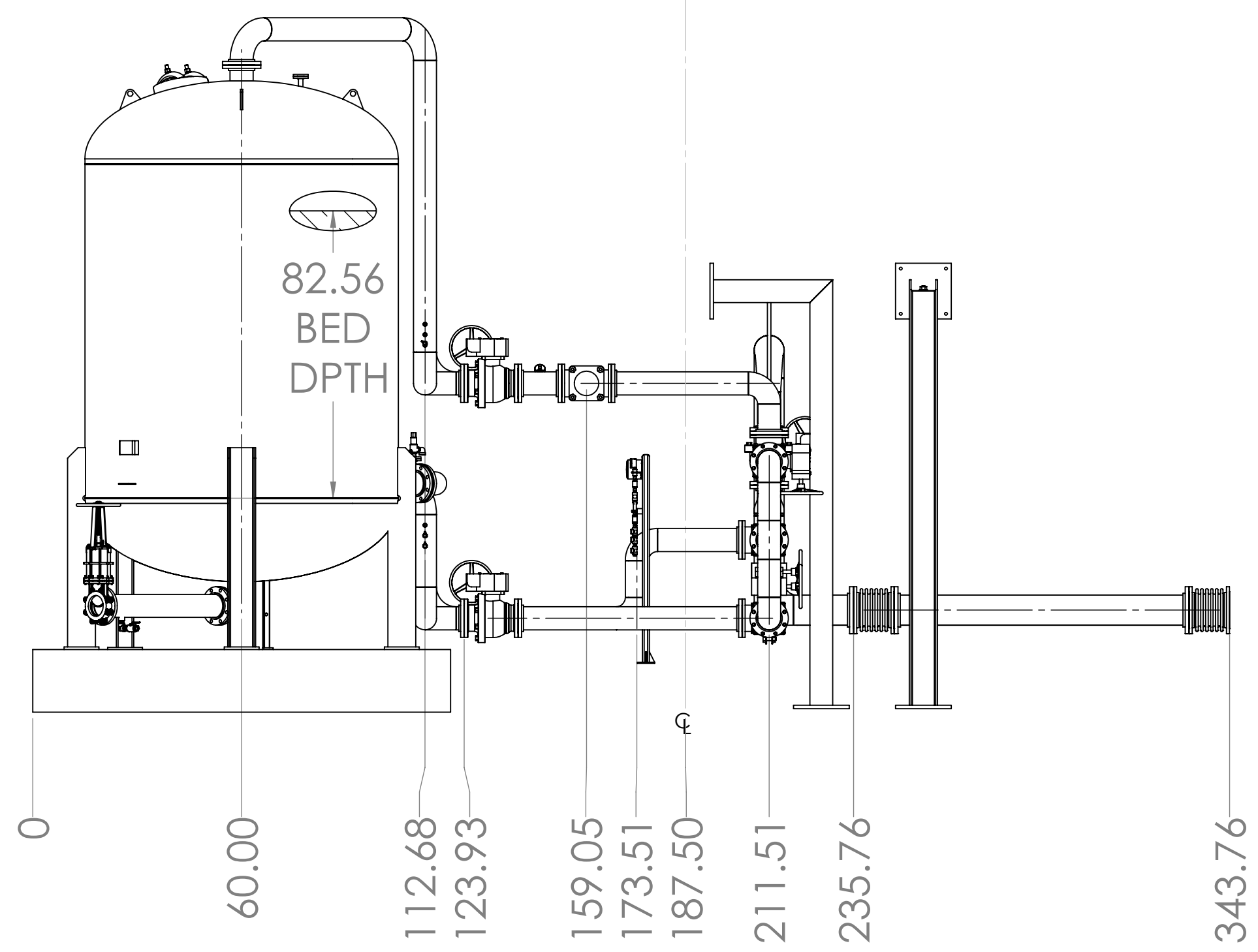
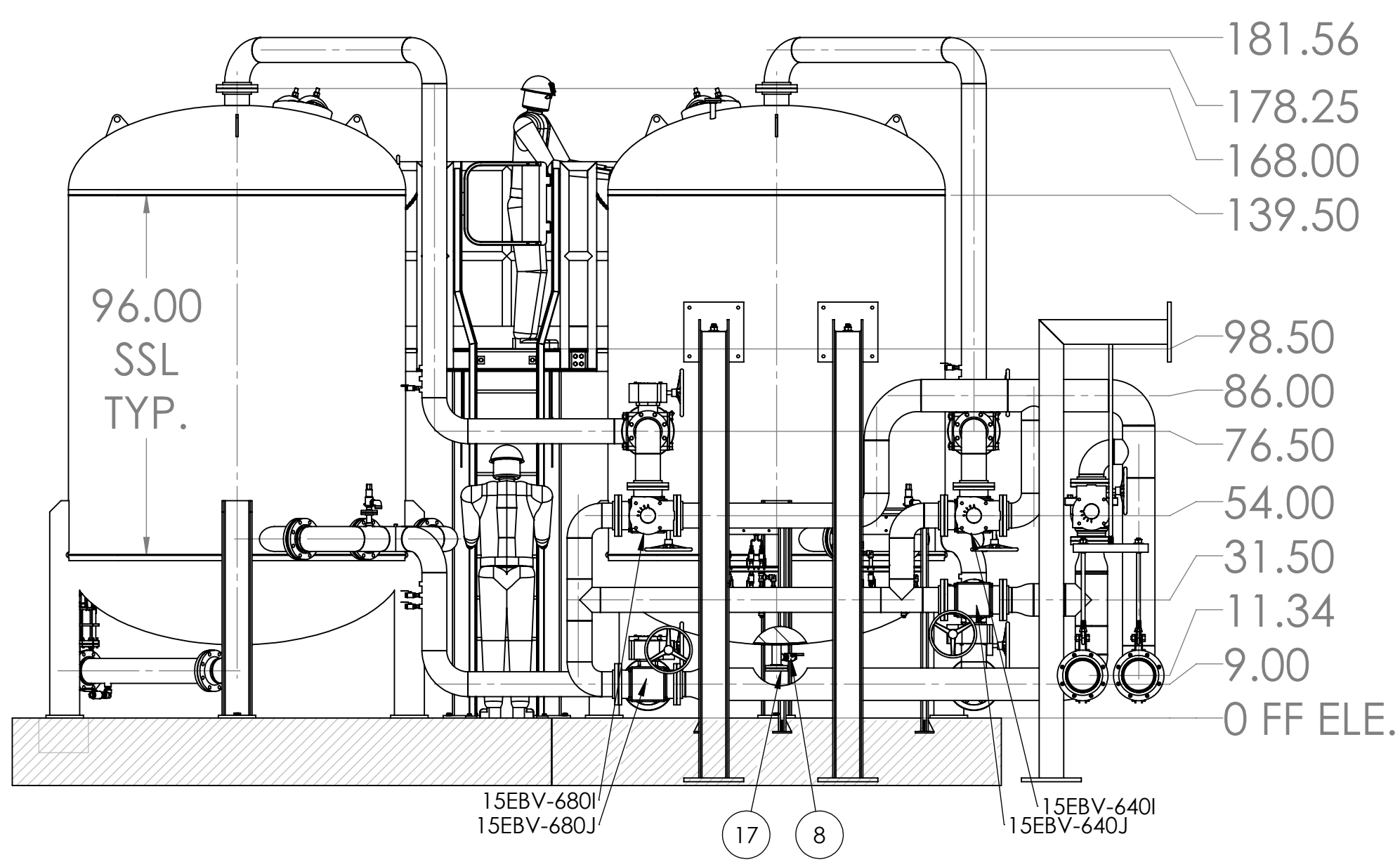

ITEM NO.	PART NUMBER	DESCRIPTION	QTY.
1	502102 WORK PLATFORM ASSY	B&V PLATFORM ASSY	1
2	500063 90IN DIA. X 96IN SSL VESSEL ASSY_AS_BUILT	Right Hand Vessel	1
3	500063 90IN DIA. X 96IN SSL VESSEL ASSY_AS_BUILT	Existing Vessel	1
4	Pipe_5-502100 OCSD SITE 2, 3 VESSEL SAG ASSEMBLY	PIPE SPOOL	1
5	502101 SEPTA FILTER	Septa, 6" 150# x 82"	6
6	800640 6in 150LB KNIFE GATE VALVE	Fabricast FV 150-BB	1
7	800447 Pressure Relief Valve, 1in x 1in	Kunkle 916, 1in inlet X 1in outlet	2
8	800216 1 IN FNPT BALL VALVE	Valve, ball, 1" SS thd, APOLLO	2
9	800022 .5in ball valve	304 SS Ball .5in Valve	6
10	Flowmeter, 6in 150LB Flanged.	John C. Ernst #216 Flow indicator	2
11	800486 THERMOWELL, .75in	.75in NPT X .5in NPT X 6in U Dim.	2
12	800488 Temp Indicator	6IN STEM LENGTH, STD MOUNT	2
13	4452K476	1in MNPT x FNPT Elbow.	2
14	Threaded Pipe 1 in, Sch 40-2	1IN, SCH 40, CLOSE, PIPE NIPPLE	3
15	Threaded Pipe 0.5 in, Sch 40-2	SCH 40 Threaded Pipe	6
16	CLASS 150 THREADED ELBOW, 1.00 IN	1" Threaded Elbow	1
17	Fig. Bld, NPS 2in, CLASS ASME 150, RF	BLIND FLANGE	1
18	Fig. Bld, NPS 1in, CLASS ASME 150, RF	BLIND FLANGE	1
19	502104 OUTDOOR INSTRUMENTATION PANEL	PI/DPI INST. PANEL	2
20	Pipe_14-502105 OCSD SITE 1 ASSEMBLY	Vessel Outlet Header Spool	1
21	Pipe_17-502105 OCSD SITE 1 ASSEMBLY	GAS INLET SPOOL	1
22	Pipe_13-502105 OCSD SITE 1 ASSEMBLY	PIPE SPOOL	1
23	Pipe_15-502105 OCSD SITE 1 ASSEMBLY	PIPE SPOOL	2
24	Pipe_12-502105 OCSD SITE 1 ASSEMBLY	PIPE SPOOL	1
25	Pipe_9-502105 OCSD SITE 1 ASSEMBLY	GAS INLET SPOOL	1
26	Pipe_10-502105 OCSD SITE 1 ASSEMBLY	Vessel Outlet Header Spool	1
27	Pipe_16-502105 OCSD SITE 1 ASSEMBLY	PIPE SPOOL	2
28	Pipe_18-502105 OCSD SITE 1 ASSEMBLY	PIPE SPOOL	1
29	Pipe_19-502105 OCSD SITE 1 ASSEMBLY	PIPE SPOOL	1
30	Pipe_20-502105 OCSD SITE 1 ASSEMBLY-001	PIPE SPOOL	1
31	800638 FLEX JOINT, 8INCH 150LB	8IN 150LB FLEXIBLE COUPLING	4
32	Pipe_21-502105 OCSD SITE 1 ASSEMBLY	PIPE SPOOL	2
33	800632 6in, 150LB Flanged Ball Valve	Ball Valve, 6inch 150lb RFSO	5
34	800641 6in, 150LB, 3 WAY BALL VALVE	6IN, 150LB, 3 WAY BALL VALVE	4
35	502109 CONSTANT SUPPORT ASSY	CONSTANT SUPPORT ASSY	2
36	502110 CONSTANT SUPPORT ASSY	CONSTANT SUPPORT ASSY	1
37	800643 GEAR OPERATOR,	SHARPE SG-16, GEAR OPERATOR	9

ROBINSON GROUP LLC
 20203 95th AVE
 TUALATIN OR 97062
 (425)420-1979

UNLESS OTHERWISE SPECIFIED:
 DIMENSIONS ARE IN INCHES
 TOLERANCES:
 FRACTIONAL ±
 ANGULAR: MACH ± BEND ±
 THREE PLACE DECIMAL ±
 INTERPRET GEOMETRIC TOLERANCES PER:
 ASME Y14.5-2009

PROPRIETARY AND CONFIDENTIAL
 THIS DRAWING IS THE PROPERTY OF ROBINSON GROUP LLC AND IS SUBJECT TO RETURN UPON REQUEST. THE INFORMATION SHOWN IS CONFIDENTIAL AND THE REPRODUCTION OR DISSEMINATION OF THIS DRAWING, IN ANY MANNER, WITHOUT PRIOR WRITTEN AUTHORIZATION OF ROBINSON GROUP LLC.

DATE: 7/24/2014
 NAME: MRH
 TITLE: OCSD SITE 1
 TITLE: 502105 OCSD SITE 1 ASSEMBLY
 TITLE: SITE 1, 2 VESSEL ARRANGEMENT
 SIZE DWG. NO. 1
 SCALE: 1:48 WEIGHT: 139162 SHEET 1 OF 1

REVISIONS				
ZONE	REV.	DESCRIPTION	DATE	APPROVED

NOTES:
 1. WEIGHT LISTED IS FULLY LADEN, WITH VESSELS FILLED WITH 9900 LB'S OF SAG MEDIA PER VESSEL
 2. VESSEL GROUNDING LUGS.

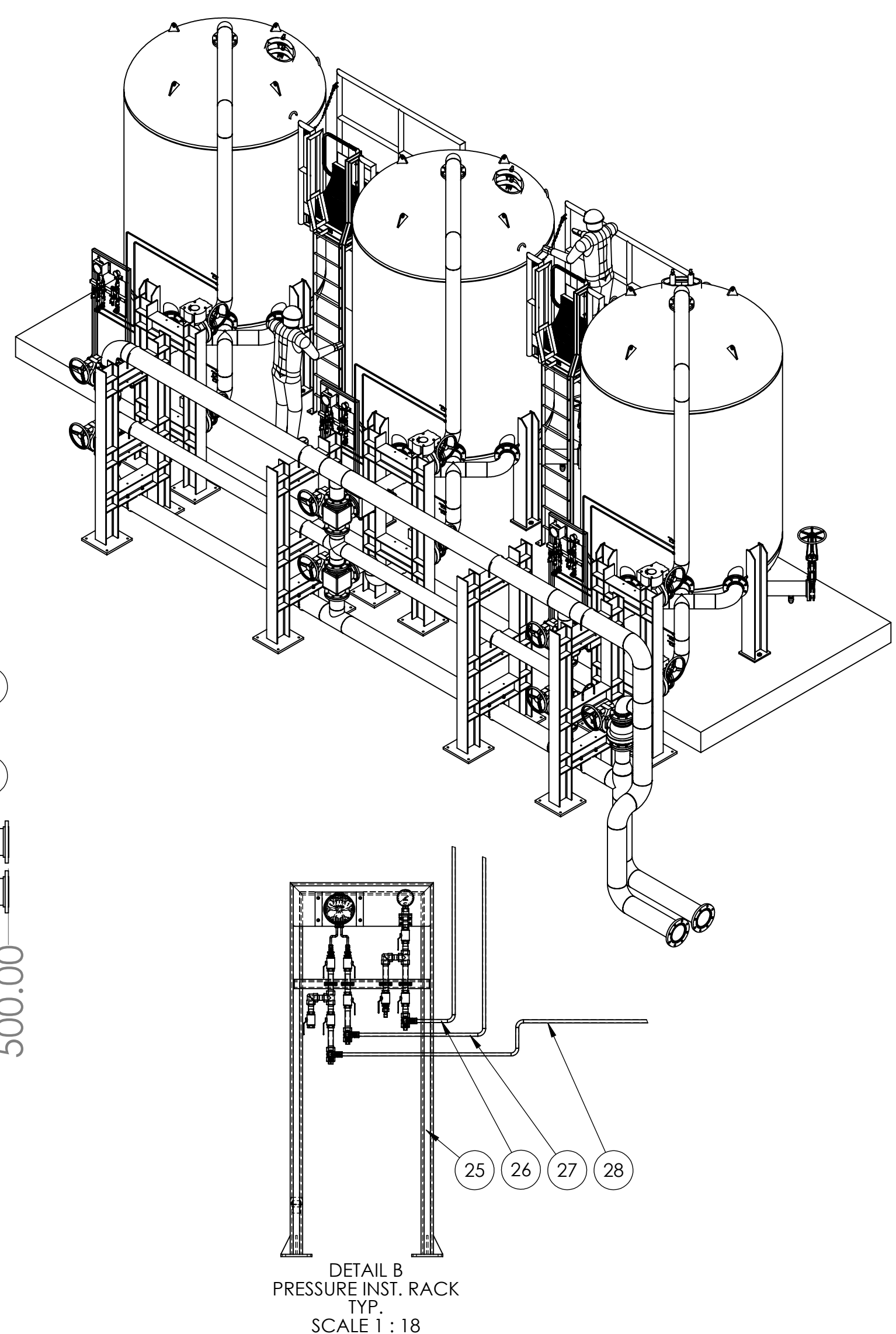
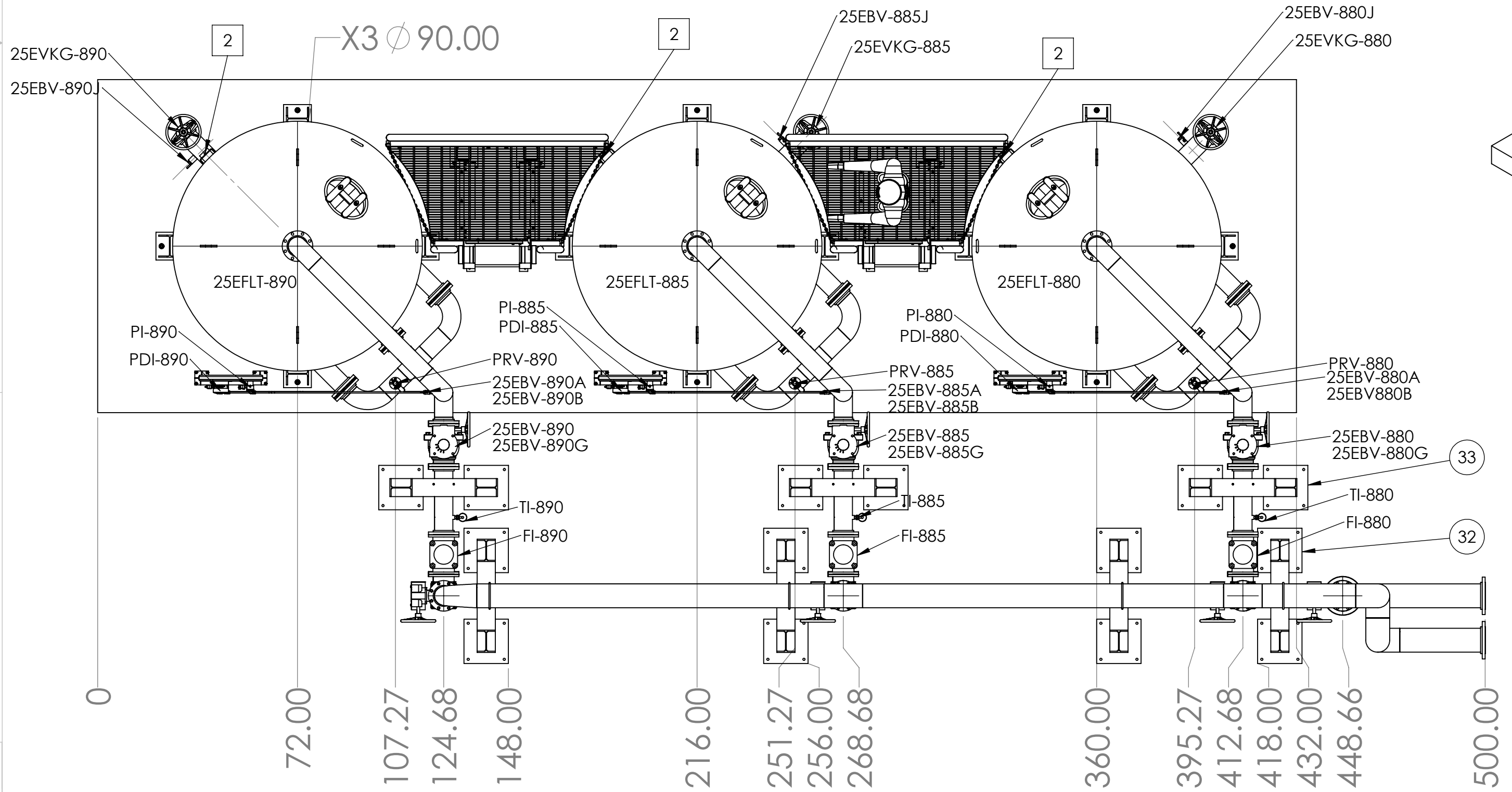
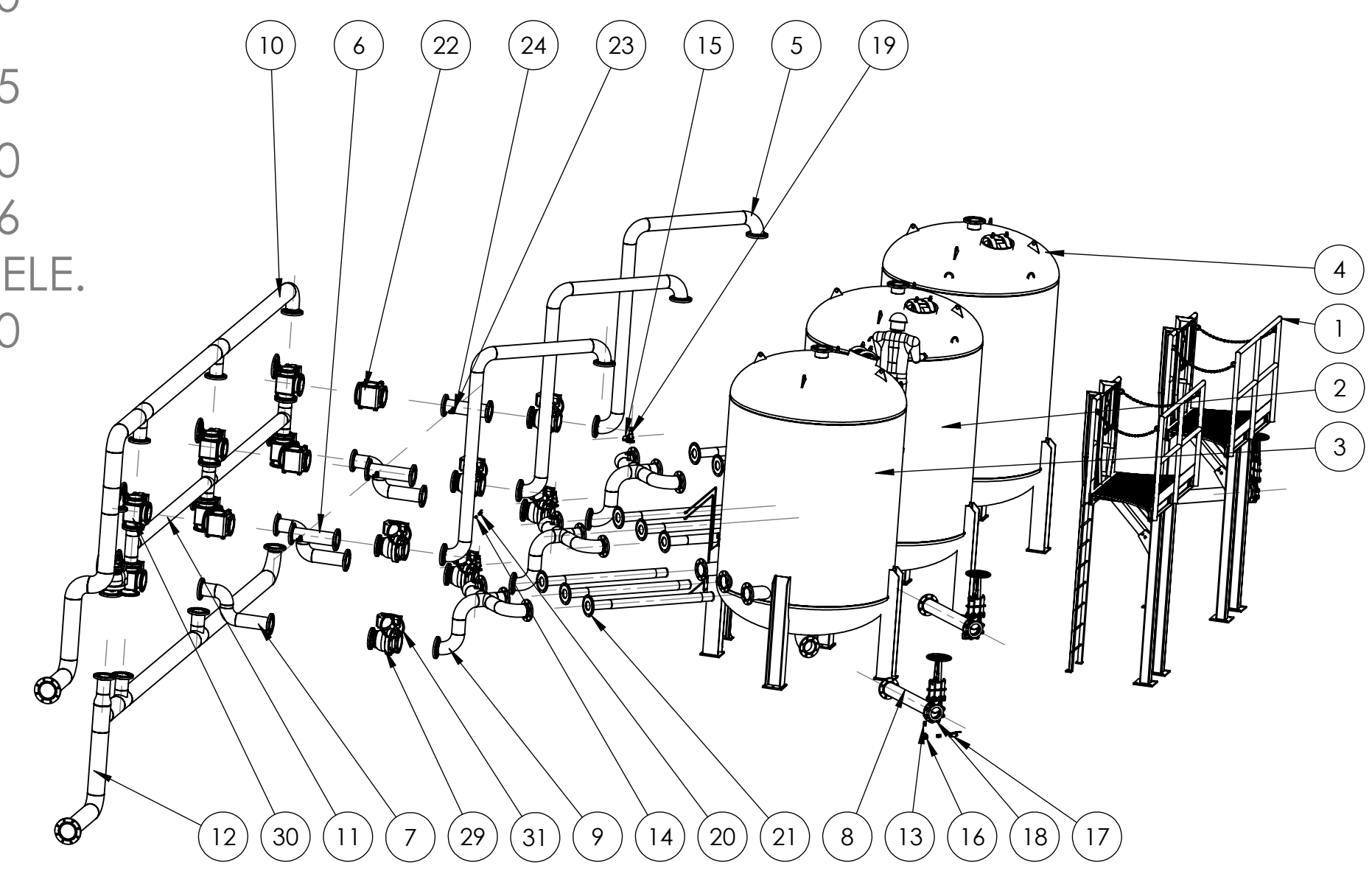
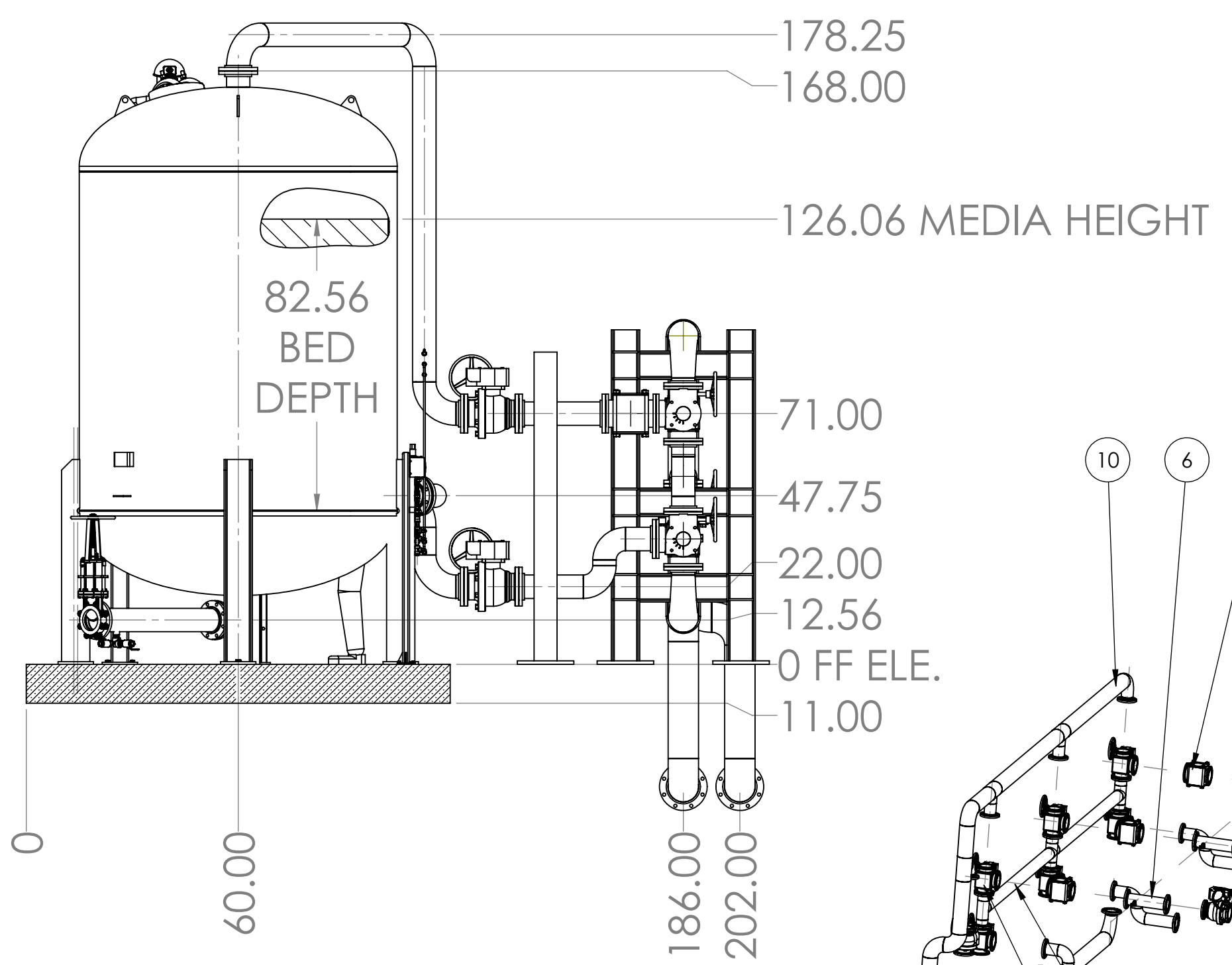
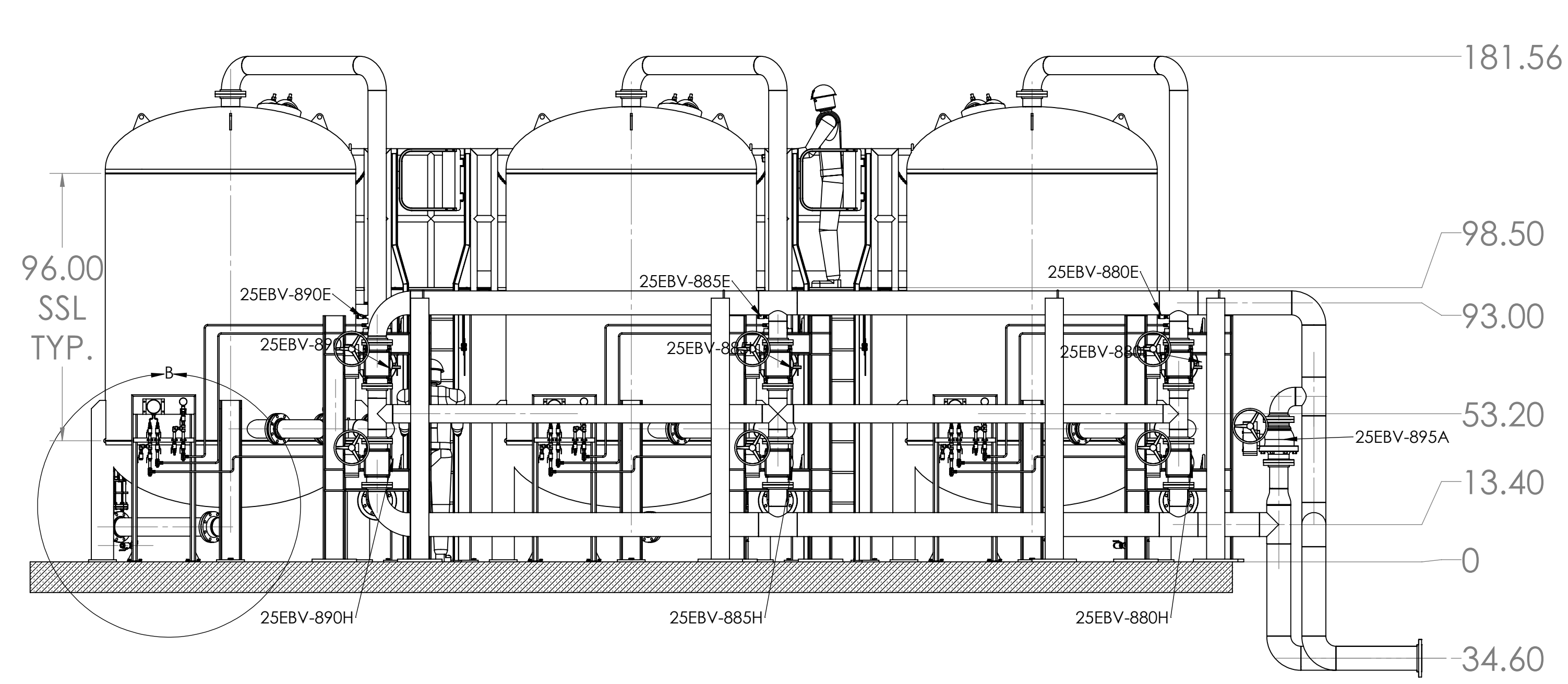

ITEM NO.	PART NUMBER	DESCRIPTION	QTY.
1	502102 WORK PLATFORM ASSY	B&V PLATFORM ASSY	1
2	500063 90IN DIA. X 96IN SSL VESSEL ASSY_AS_BUILT	Right Hand Vessel Alt Drain	2
3	500063 90IN DIA. X 96IN SSL VESSEL ASSY_AS_BUILT	Left Hand Vessel	1
4	500063 90IN DIA. X 96IN SSL VESSEL ASSY_AS_BUILT	Right Hand Vessel	1
5	Pipe_2-502100 OCSD SITE 2, 3 VESSEL ASSEMBLY	GAS INLET SPOOL	3
6	Pipe_3-502100 OCSD SITE 2, 3 VESSEL ASSEMBLY	PIPE SPOOL	3
7	Pipe_4-502100 OCSD SITE 2, 3 VESSEL ASSEMBLY	PIPE SPOOL	3
8	Pipe_5-502100 OCSD SITE 2, 3 VESSEL SAG ASSEMBLY	PIPE SPOOL	3
9	Pipe_6-502100 OCSD SITE 2, 3 VESSEL ASSEMBLY	Vessel Outlet Header Spool	3
10	Pipe_7-502100 OCSD SITE 2, 3 VESSEL ASSEMBLY	PIPE SPOOL	1
11	Pipe_8-502100 OCSD SITE 2, 3 VESSEL ASSEMBLY	PIPE SPOOL	1
12	Pipe_9-502100 OCSD SITE 2, 3 VESSEL ASSEMBLY	PIPE SPOOL	1
13	Threaded Pipe 1 in, Sch 40-2	1IN, SCH 40, CLOSE, PIPE NIPPLE	6
14	Threaded Pipe 0.5 in, Sch 40-1.5	.5IN SCH40, CLOSE, PIPE NIPPLE	9
15	4452K476	1in MNPT x FNPT Elbow.	3
16	CLASS 3000 THREADED ELBOW, 1.00 IN	90 degree elbow, threaded	3
17	800216 1 IN FNPT BALL VALVE	Valve, ball, 1" SS thd, APOLLO	3
18	800640 6in 150LB KNIFE GATE VALVE	Fabricast FV 150-BB	3
19	800447 Pressure Relief Valve, 1in x 1in	Kunkle 916, 1in inlet X 1in outlet	3
20	800022 .5in ball valve	304 SS Ball .5in Valve	9
21	502101 SEPTA FILTER	Septa, 6" 150# x 82"	9
22	Flowmeter, 6in 150LB Flanged.	John C. Ernst #216 Flow indicator	3
23	800486 THERMOWELL, .75in	.75in NPT X .5in NPT X 6in U Dim.	3
24	800488 Temp Indicator	6IN STEM LENGTH, STD MOUNT	3
25	502104 OUTDOOR INSTRUMENTATION PANEL	PI/DPI INST. PANEL	3
26	Tube_3-502100 OCSD SITE 2, 3 VESSEL SAG ASSEMBLY	PI TUBING ASSY	3
27	Tube_4-502100 OCSD SITE 2, 3 VESSEL SAG ASSEMBLY	HI DPI TUBING	3
28	Tube_5-502100 OCSD SITE 2, 3 VESSEL SAG ASSEMBLY	LOW DPI TUBING	3
29	800632 6in, 150LB Flanged Ball Valve	Ball Valve, 6inch 150lb RFSO	7
30	800641 6in, 150LB, 3 WAY BALL VALVE	6IN, 150LB, 3 WAY BALL VALVE	6
31	800643 GEAR OPERATOR,	SHARPE SG-16, GEAR OPERATOR	13
32	502110 PIPE SUPPORT RACK	FIXED PIPE SUPPORT RACK, SITE 2	4
33	502112 PIPE SUPPORT RACK ASSY	W8X28 PIPE RACK SUPPORT	3

ROBINSON GROUP LLC
 20203 95th AVE
 TUALATIN OR 97062
 (425)420-1979

UNLESS OTHERWISE SPECIFIED:
 DIMENSIONS ARE IN INCHES
 TOLERANCES:
 FRACTIONAL ±
 ANGULAR: MACH ±
 BEND ±
 TWO PLACE DECIMAL ±
 THREE PLACE DECIMAL ±
 INTERPRET GEOMETRIC TOLERANCES PER:
 ASME Y14.5-2009

PROPRIETARY AND CONFIDENTIAL
 THIS DRAWING IS THE PROPERTY OF ROBINSON GROUP LLC AND IS SUBJECT TO RETURN UPON REQUEST. THE INFORMATION SHOWN HEREON IS UNCLASSIFIED AND NOT CONTROLLED INFORMATION. ANY REPRODUCTION OR DISSEMINATION OF THIS DRAWING, IN ANY MANNER, WITHOUT WRITTEN AUTHORIZATION OF ROBINSON GROUP LLC.

DATE: 7/25/2014
 NAME: MRH
 DRAWN: MRH
 CHECKED: MRH
 ENG APPR: MRH
 MFG APPR: MRH
 P&ID REF #
 COMMENTS:

OCSD SITE 2
 TITLE: 502100 OCSD SITE 2, 3 VESSEL SAG ASSEMBLY
 3 VESSEL, DOWNFLOW, LEAD LAG, SAG ASSY, 90IN DIA X 96IN SSL

SIZE DWG. NO. 1
 REV 0
 SCALE: 1:48 WEIGHT: SHEET 1 OF 1

Exhibit “B”

BID

Bid Results

Bidder Details

Vendor Name Carbon Bulk Sales
Address 1791 Kaiser Ave
Irvine, California 92614
United States
Respondee Joseph Hunter
Respondee Title Account Manager
Phone 949-732-3318
Email jhunter@carbonbulksales.com
Vendor Type
License #
CADIR

Bid Detail

Bid Format Electronic
Submitted 04/26/2022 1:07 PM (PDT)
Delivery Method
Bid Responsive Yes
Bid Status Submitted
Confirmation # 289183

Respondee Comment

Buyer Comment

Attachments

File Title	File Name	File Type
OSCD Bid - Exhibit M.pdf	OSCD Bid - Exhibit M.pdf	Exhibit M
OCSD Bid - Exhibit_ K,L.pdf	OCSD Bid - Exhibit_ K,L.pdf	Exhibits K,L
OCSD Bid - Exhibit_ C,G,H,I,J.pdf	OCSD Bid - Exhibit_ C,G,H,I,J.pdf	Exhibits C,G,H,I,J

Line Items

Discount Terms No Discount

Item #	Item Code	Type	Item Description	UOM	QTY	Unit Price	Line Total	Response	Comment
Total Lump Sum Cost for up to Twelve (12) Service/Change-Outs of the Digester Gas Fuel Filter System Media at Plants 1 & 2 including Labor, Materials, Installation, Disposal, CA Sales Tax, Supplies, Misc. Cost and Freight (F.O.B. Destination). OC San Does Not Guarantee Usage.							\$420,972.00		
1			Total Cost for One (1) Service/Change-Out of the Digester Gas Fuel Filter System Media at Plant 1 (Fountain Valley) including Labor, Materials, Installation, Disposal, CA Sales Tax, Supplies, Misc. Cost and Freight (F.O.B. Destination). Estimated at 5 change outs per year	Per Service/Change Out	5	\$35,081.00	\$175,405.00	Yes	
2			Total Cost for One (1) Service/Change-Out of the Digester Gas Fuel Filter System Media at Plant 2 (Huntington Beach) including Labor, Materials, Installation, Disposal, CA Sales Tax, Supplies, Misc. Cost and Freight (F.O.B. Destination). Estimated at 7 change outs per year	Per Service/Change Out	7	\$35,081.00	\$245,567.00	Yes	

Line Item Subtotals

Section Title	Line Total
Total Lump Sum Cost for up to Twelve (12) Service/Change-Outs of the Digester Gas Fuel Filter System Media at Plants 1 & 2 including Labor, Materials, Installation, Disposal, CA Sales Tax, Supplies, Misc. Cost and Freight (F.O.B. Destination). OC San Does Not Guarantee Usage.	\$420,972.00
<p style="text-align: right;">Grand Total</p>	\$420,972.00