



SPECIAL NOTICE
PUBLIC ATTENDANCE & PARTICIPATION AT PUBLIC MEETINGS
Steering Committee Meeting
Wednesday, January 17, 2024
3:00 p.m.

Your participation is always welcome. OC San offers several ways in which to interact during meetings. You will find information as to these opportunities below.

IN-PERSON MEETING ATTENDANCE

You may attend the meeting in-person at the following location:

Orange County Sanitation District
Administration Building
10844 Ellis Avenue
Fountain Valley, CA 92708

ONLINE MEETING PARTICIPATION

You may join the meeting live via Teams on your computer or similar device or web browser by using the link below:

[Click here to join the meeting](#)

We suggest testing joining a Teams meeting on your device prior to the commencement of the meeting. For recommendations, general guidance on using Teams, and instructions on joining a Teams meeting, [please click here](#).

Please mute yourself upon entry to the meeting. Please raise your hand if you wish to speak during the public comment section of the meeting. The Clerk of the Board will call upon you by using the name you joined with.

Meeting attendees are not provided the ability to make a presentation during the meeting. Please contact the Clerk of the Board at least 48 hours prior to the meeting if you wish to present any items. Additionally, camera feeds may be controlled by the meeting moderator to avoid inappropriate content.

HOW TO PARTICIPATE IN THE MEETING BY TELEPHONE

To join the meeting from your phone: Dial (213) 279-1455
When prompted, enter the Phone Conference ID: 666 378 27#

All meeting participants may be muted during the meeting to alleviate background noise. If you are muted, please use *6 to unmute. You may also mute yourself on your device.

Please raise your hand to speak by use *5, during the public comment section of the meeting. The Clerk of the Board will call upon you by using the last 4 digits of your phone number as identification.

NOTE: All attendees will be disconnected from the meeting at the beginning of Closed Session. If you would like to return to the Open Session portion of the meeting, please login or dial-in to the Teams meeting again and wait in the Lobby for admittance.

WATCH THE MEETING ONLINE

The meeting will be available for online viewing at:

<https://ocsd.legistar.com/Calendar.aspx>

SUBMIT A COMMENT

You may submit your comments and questions in writing for consideration in advance of the meeting by using the eComment feature available online at: <https://ocsd.legistar.com/Calendar.aspx> or sending them to OCSanClerk@ocsan.gov with the subject line "PUBLIC COMMENT ITEM # (insert the item number relevant to your comment)" or "PUBLIC COMMENT NON-AGENDA ITEM".

You may also submit comments and questions for consideration during the meeting by using the eComment feature available online at: <https://ocsd.legistar.com/Calendar.aspx>. The eComment feature will be available for the duration of the meeting.

All written public comments will be provided to the legislative body and may be read into the record or compiled as part of the record.

For any questions and/or concerns, please contact the Clerk of the Board's office at 714-593-7433. Thank you for your interest in OC San!

January 10, 2024

NOTICE OF SPECIAL MEETING

**STEERING COMMITTEE
ORANGE COUNTY SANITATION DISTRICT**

Wednesday, January 17, 2024 – 3:00 P.M.

Administration Building
10844 Ellis Avenue
Fountain Valley, CA 92708

ACCESSIBILITY FOR THE GENERAL PUBLIC

Your participation is always welcome. Specific information as to how to participate in this meeting is detailed on the Special Notice attached to this agenda. In general, OC San offers several ways in which to interact during this meeting: you may participate in person, join the meeting live via Teams on your computer or similar device or web browser, join the meeting live via telephone, view the meeting online, and/or submit comments for consideration before or during the meeting.

The Special Meeting of the Steering Committee of the Orange County Sanitation District will be held at the above location and in the manner indicated on Wednesday, January 17, 2024 at 3:00 p.m.



Clerk of the Board

- Serving:
- Anaheim
- Brea
- Buena Park
- Cypress
- Fountain Valley
- Fullerton
- Garden Grove
- Huntington Beach
- Irvine
- La Habra
- La Palma
- Los Alamitos
- Newport Beach
- Orange
- Placentia
- Santa Ana
- Seal Beach
- Stanton
- Tustin
- Villa Park
- County of Orange
- Costa Mesa Sanitary District
- Midway City Sanitary District
- Irvine Ranch Water District
- Yorba Linda Water District

STEERING COMMITTEE & BOARD MEETING DATES

February 28, 2024

March 27, 2024

April 24, 2024

May 22, 2024

June 26, 2024

July 24, 2024

August 28, 2024

September 25, 2024

October 23, 2024

November 20, 2024 *

December 18, 2024 *

January 22, 2025

**** Meeting will be held on the third Wednesday of the month***

**ROLL CALL
STEERING COMMITTEE**

Meeting Date: January 17, 2024

Time: 3:00 p.m.

Adjourn: _____

COMMITTEE MEMBERS (7)

Chad Wanke, Board Chair	
Ryan Gallagher, Board Vice-Chair	
Jon Dumitru, Operations Committee Chair	
Christine Marick, Administration Committee Chair	
Pat Burns, Member-At-Large	
John Withers, Member-At-Large	
VACANT, Member-At-Large	

OTHERS

Brad Hogin, General Counsel	
-----------------------------	--

STAFF

Rob Thompson, General Manager	
Lorenzo Tyner, Assistant General Manager	
Mike Dorman, Director of Engineering	
Laura Maravilla, Director of Human Resources	
Riaz Moinuddin, Director of Operations & Maintenance	
Wally Ritchie, Director of Finance	
Lan Wiborg, Director of Environmental Services	
Kelly Lore, Clerk of the Board	

ORANGE COUNTY SANITATION DISTRICT
BOARD OF DIRECTORS
Complete Roster

Effective 1/10/2024

AGENCY/CITIES	ACTIVE DIRECTOR	ALTERNATE DIRECTOR
Anaheim	Stephen Faessel	Carlos A. Leon
Brea	Christine Marick	Cecilia Hupp
Buena Park	Susan Sonne	Art Brown
Cypress	Scott Minikus	Bonnie Peat
Fountain Valley	Glenn Grandis	Ted Bui
Fullerton	Bruce Whitaker	Nick Dunlap
Garden Grove	Stephanie Klopfenstein	John O'Neill
Huntington Beach	Pat Burns	Gracey Van Der Mark
Irvine	Farrah N. Khan	Kathleen Treseder
La Habra	Rose Espinoza	Jose Medrano
La Palma	Debbie Baker	Mark I. Waldman
Los Alamitos	Jordan Nefulda	Shelley Hasselbrink
Newport Beach	Brad Avery	Erik Weigand
Orange	Jon Dumitru	John Gyllenhammer
Placentia	Chad Wanke	Ward Smith
Santa Ana	Johnathan Ryan Hernandez	Benjamin Vazquez
Seal Beach	Schelly Sustarsic	Nathan Steele
Stanton	David Shawver	Carol Warren
Tustin	Ryan Gallagher	Austin Lumbard
Villa Park	Robbie Pitts	Jordan Wu

Sanitary/Water Districts

Costa Mesa Sanitary District	Bob Ooten	Art Perry
Midway City Sanitary District	Andrew Nguyen	Tyler Diep
Irvine Ranch Water District	John Withers	Douglas Reinhart
Yorba Linda Water District	Phil Hawkins	Tom Lindsey

County Areas

Board of Supervisors	Doug Chaffee	Donald P. Wagner
----------------------	--------------	------------------



STEERING COMMITTEE
Special Meeting Agenda
Wednesday, January 17, 2024 - 3:00 PM
Conference Room A
Administration Building
10844 Ellis Avenue
Fountain Valley, CA 92708
(714) 593-7433

ACCOMMODATIONS FOR THE DISABLED: If you require any special disability related accommodations, please contact the Orange County Sanitation District (OC San) Clerk of the Board's office at (714) 593-7433 at least 72 hours prior to the scheduled meeting. Requests must specify the nature of the disability and the type of accommodation requested.

AGENDA POSTING: In accordance with the requirements of California Government Code Section 54954.2, this agenda has been posted outside the main gate of the OC San's Administration Building located at 10844 Ellis Avenue, Fountain Valley, California, and on the OC San's website at www.ocsan.gov not less than 72 hours prior to the meeting date and time above. All public records relating to each agenda item, including any public records distributed less than 72 hours prior to the meeting to all, or a majority of the Board of Directors, are available for public inspection in the office of the Clerk of the Board.

AGENDA DESCRIPTION: The agenda provides a brief general description of each item of business to be considered or discussed. The recommended action does not indicate what action will be taken. The Board of Directors may take any action which is deemed appropriate.

MEETING RECORDING: A recording of this meeting is available within 24 hours after adjournment of the meeting at <https://ocsd.legistar.com/Calendar.aspx> or by contacting the Clerk of the Board at (714) 593-7433.

NOTICE TO DIRECTORS: To place items on the agenda for a Committee or Board Meeting, the item must be submitted in writing to the Clerk of the Board: Kelly A. Lore, MMC, (714) 593-7433 / klore@ocsan.gov at least 14 days before the meeting.

FOR ANY QUESTIONS ON THE AGENDA, BOARD MEMBERS MAY CONTACT STAFF AT:

General Manager: Rob Thompson, rthompson@ocsan.gov / (714) 593-7110
Asst. General Manager: Lorenzo Tyner, ltyner@ocsan.gov / (714) 593-7550
Director of Engineering: Mike Dorman, mdorman@ocsan.gov / (714) 593-7014
Director of Environmental Services: Lan Wiborg, lwiborg@ocsan.gov / (714) 593-7450
Director of Finance: Wally Ritchie, writchie@ocsan.gov / (714) 593-7570
Director of Human Resources: Laura Maravilla, lmavilla@ocsan.gov / (714) 593-7007
Director of Operations & Maintenance: Riaz Moinuddin, rmoinuddin@ocsan.gov / (714) 593-7269

CALL TO ORDER**ROLL CALL AND DECLARATION OF QUORUM:**

Clerk of the Board

PUBLIC COMMENTS:

Your participation is always welcome. Specific information as to how to participate in a meeting is detailed in the Special Notice attached to this agenda. In general, OC San offers several ways in which to interact during meetings: you may participate in person, join the meeting live via Teams on your computer or similar device or web browser, join the meeting live via telephone, view the meeting online, and/or submit comments for consideration before or during the meeting.

REPORTS:

The Board Chairperson and the General Manager may present verbal reports on miscellaneous matters of general interest to the Directors. These reports are for information only and require no action by the Directors.

CONSENT CALENDAR:

Consent Calendar Items are considered to be routine and will be enacted, by the Committee, after one motion, without discussion. Any items withdrawn from the Consent Calendar for separate discussion will be considered in the regular order of business.

1. APPROVAL OF MINUTES**[2024-3387](#)****RECOMMENDATION:**

Approve minutes of the Regular meeting of the Steering Committee held December 14, 2023.

Originator: Kelly Lore

Attachments: [Agenda Report](#)
[12-14-2023 Steering Committee Minutes](#)

2. PUBLIC AFFAIRS UPDATE FOR THE MONTH OF DECEMBER 2023**[2024-3402](#)**

RECOMMENDATION: Recommend to the Board of Directors to:

Receive and file the Public Affairs Update for the month of December 2023.

Originator: Rob Thompson

Attachments: [Agenda Report](#)
[Outreach and Media Report - December 2023](#)

3. **LEGISLATIVE AFFAIRS UPDATE FOR THE MONTH OF DECEMBER 2023** [2024-3431](#)

RECOMMENDATION: Recommend to the Board of Directors to:

Receive and file the Legislative Affairs Update for the month of December 2023.

Originator: Rob Thompson

Attachments: [Agenda Report](#)
[Federal Legislative Update](#)
[Federal 2023 Legislative Year In Review](#)
[State Legislative Update](#)
[State 2023 Legislative Year In Review](#)

NON-CONSENT:

4. **GENERAL MANAGER'S FY 2023-2024 WORK PLAN MID-YEAR REPORT** [2023-3362](#)

RECOMMENDATION: Recommend to the Board of Directors to:

Receive and file the General Manager's FY 2023-2024 Work Plan Mid-Year Report.

Originator: Rob Thompson

Attachments: [Agenda Report](#)
[General Manager's FY 2023-2024 Work Plan Mid-Year Report](#)

5. **PUBLIC AFFAIRS STRATEGIC PLAN FOR FISCAL YEARS 2022-2024 MID-YEAR UPDATE** [2023-3363](#)

RECOMMENDATION: Recommend to the Board of Directors to:

Receive and file the Public Affairs Strategic Plan for Fiscal Years 2022- 2024 Mid-Year Update.

Originator: Rob Thompson

Attachments: [Agenda Report](#)
[Public Affairs Strategic Plan, FY 2022-2024](#)

6. **REIMBURSEMENT AGREEMENT FOR ORANGE COUNTY SANITATION DISTRICT MANHOLE FRAME AND COVER ADJUSTMENTS ON PACIFIC COAST HIGHWAY IN THE CITY OF NEWPORT BEACH** [2024-3405](#)

RECOMMENDATION: Recommend to the Board of Directors to:

Approve the Reimbursement Agreement with the City of Newport Beach titled "Reimbursement Agreement (Orange County Sanitation District Manhole Adjustment)" for an amount not to exceed \$689,699 for Orange County Sanitation District manhole frame and cover adjustments on Pacific Coast Highway in the City of Newport Beach in a form approved by Special Counsel.

Originator: Mike Dorman

Attachments: [Agenda Report](#)
[Reimbursement Agreement](#)

INFORMATION ITEMS:

7. SOLICITATION OF GENERAL LEGAL SERVICES [2024-3433](#)

RECOMMENDATION:

Provide an update on the solicitation, scope of work, and contract structure for the upcoming General Legal Services procurement.

Originator: Lorenzo Tyner

Attachments: [Agenda Report](#)
[Draft General Legal Services Scope of Work - 01.08.2024](#)

DEPARTMENT HEAD REPORTS:

CLOSED SESSION:

During the course of conducting the business set forth on this agenda as a regular meeting of the Board, the Chairperson may convene the Board in closed session to consider matters of pending real estate negotiations, pending or potential litigation, or personnel matters, pursuant to Government Code Sections 54956.8, 54956.9, 54957 or 54957.6, as noted.

Reports relating to (a) purchase and sale of real property; (b) matters of pending or potential litigation; (c) employment actions or negotiations with employee representatives; or which are exempt from public disclosure under the California Public Records Act, may be reviewed by the Board during a permitted closed session and are not available for public inspection. At such time the Board takes final action on any of these subjects, the minutes will reflect all required disclosures of information.

CONVENE IN CLOSED SESSION.

CS-1 PUBLIC EMPLOYEE PERFORMANCE EVALUATION 54957(b)(1) [2023-3333](#)

RECOMMENDATION: Convene in Closed Session:

Public Employee Performance Evaluation

Number of Employees: 1

- General Counsel

Attachments: [Agenda Report](#)
[Steering CS Memo re General Counsel Evaluation 1-8-24](#)

CS-2 CONFERENCE WITH LEGAL COUNSEL RE ANTICIPATED LITIGATION - GOVERNMENT CODE SECTION 54956.9(d)(4) [2024-3436](#)

RECOMMENDATION: Convene in Closed Session:

Number of Potential Cases: 1

Potential initiation of litigation regarding Miller-Holder Easement.

Attachments: [Agenda Report](#)
[Steering CS Memo re Miller-Holder 1-8-24](#)

RECONVENE IN REGULAR SESSION.

CONSIDERATION OF ACTION, IF ANY, ON MATTERS CONSIDERED IN CLOSED SESSION:

OTHER BUSINESS AND COMMUNICATIONS OR SUPPLEMENTAL AGENDA ITEMS, IF ANY:

BOARD OF DIRECTORS INITIATED ITEMS FOR A FUTURE MEETING:

At this time Directors may request staff to place an item on a future agenda.

ADJOURNMENT:

Adjourn the meeting until the Regular Meeting of the Steering Committee on February 28, 2024 at 5:00 p.m.



STEERING COMMITTEE

Agenda Report

Administration Building
10844 Ellis Avenue
Fountain Valley, CA 92708
(714) 593-7433

File #: 2024-3387

Agenda Date: 1/17/2024

Agenda Item No: 1.

FROM: Robert Thompson, General Manager
Originator: Kelly A. Lore, Clerk of the Board

SUBJECT:

APPROVAL OF MINUTES

GENERAL MANAGER'S RECOMMENDATION

RECOMMENDATION:

Approve minutes of the Regular meeting of the Steering Committee held December 14, 2023.

BACKGROUND

In accordance with the Board of Directors Rules of Procedure, an accurate record of each meeting will be provided to the Directors for subsequent approval at the following meeting.

RELEVANT STANDARDS

- Resolution No. OC SAN 22-37

ATTACHMENT

The following attachment(s) may be viewed on-line at the OC San website (www.ocsan.gov) with the complete agenda package:

- December 14, 2023 Steering Committee meeting minutes



CALL TO ORDER

A regular meeting of the Steering Committee of the Orange County Sanitation District was called to order by Board Vice-Chairman Ryan Gallagher on Thursday, December 14, 2023 at 5:00 p.m. in the Administration Building of the Orange County Sanitation District.

ROLL CALL AND DECLARATION OF QUORUM:

The Clerk of the Board declared a quorum present as follows:

PRESENT: Ryan Gallagher, Pat Burns, Christine Marick, John Withers and Jon Dumitru
ABSENT: Chad Wanke and Marshall Goodman

STAFF PRESENT: Rob Thompson, General Manager; Lorenzo Tyner, Assistant General Manager; Michael Dorman, Director of Engineering; Laura Maravilla, Director of Human Resources; Riaz Moinuddin, Director of Operations and Maintenance; Wally Ritchie, Director of Finance; Lan Wiborg, Director of Environmental Services; Kelly Lore, Clerk of the Board; Mo Abiodun; Jackie Castro; Daisy Covarrubias; Tanya Chong; Thys DeVries; Martin Dix; Justin Fenton; Rebecca Long; Rob Michaels; Eros Yong; and Ruth Zintzun were present in Conference Room A.

OTHERS PRESENT: Brad Hogin, General Counsel; Lindsey Caro and Gary Weisberg, Associate Counsel, Woodruff & Smart; and Rob Coppedge, Special Counsel, were present in Conference Room A. Eric O' Donnell, Townsend Public Affairs; and Eric Sapirstein, ENS Resources, were present telephonically.

PUBLIC COMMENTS:

None.

REPORTS:

Board Vice-Chair Gallagher did not provide a report.

General Manager Rob Thompson provided a brief update to the Raul Palazuelos litigation and stated the case had been successfully resolved.

CONSENT CALENDAR:**1. APPROVAL OF MINUTES**[2023-3331](#)**Originator:** Kelly Lore

MOVED, SECONDED, AND DULY CARRIED TO:

Approve minutes of the Regular meeting of the Steering Committee held November 15, 2023.

AYES: Ryan Gallagher, Pat Burns, Christine Marick, John Withers and Jon Dumitru**NOES:** None**ABSENT:** Chad Wanke and Marshall Goodman**ABSTENTIONS:** None**2. LEGISLATIVE AFFAIRS UPDATE FOR THE MONTH OF NOVEMBER 2023**[2023-3339](#)**Originator:** Rob Thompson

MOVED, SECONDED, AND DULY CARRIED TO: Recommend to the Board of Directors to:

Receive and file the Legislative Affairs Update for the month of November 2023.

AYES: Ryan Gallagher, Pat Burns, Christine Marick, John Withers and Jon Dumitru**NOES:** None**ABSENT:** Chad Wanke and Marshall Goodman**ABSTENTIONS:** None**3. PUBLIC AFFAIRS UPDATE FOR THE MONTH OF NOVEMBER 2023**[2023-3340](#)**Originator:** Rob Thompson

MOVED, SECONDED, AND DULY CARRIED TO: Recommend to the Board of Directors to:

Receive and file the Public Affairs Update for the month of November 2023.

AYES: Ryan Gallagher, Pat Burns, Christine Marick, John Withers and Jon Dumitru**NOES:** None**ABSENT:** Chad Wanke and Marshall Goodman**ABSTENTIONS:** None

NON-CONSENT:**4. SOLICITATION OF GENERAL LEGAL COUNSEL SERVICES**[2023-3344](#)**Originator:** Wally Ritchie

Board Vice-Chair Gallagher provided an overview of the General Legal Services Ad Hoc Committee's discussion from the Committee's meeting earlier today and requested any input on the General Legal Services Ad Hoc Committee's recommendations. He stated that it was the consensus of the Ad Hoc Committee to proceed with an RFP + small percentage cost component for solicitation. The Committee requested a flexible solicitation with the option to submit a proposal for legal services as a whole, as a portion, or as only one category of the seven categories discussed. It was agreed that staff would provide the initial written scoring component; and would provide all scores to the Ad Hoc Committee to draw the line. It was recommended that the Ad Hoc Committee interview all firms above the line drawn for all disciplines, and would then provide a recommendation to the Steering Committee; the full Steering Committee will interview the top two firms for General Counsel and make a recommendation to the Board of Directors. The Ad Hoc Committee also recommended that the Contract duration be five (5) years with one (1) five-year extension. Staff anticipates holding interviews during the May Steering Committee meeting. In response to a request from Director John Withers, Finance and Procurement Manager Ruth Zintzun stated that a full written scope and process would be provided at the Ad Hoc Committee's next meeting in January.

INFORMATION ITEMS:

None.

DEPARTMENT HEAD REPORTS:

None.

CLOSED SESSION:**CONVENED IN CLOSED SESSION PURSUANT TO GOVERNMENT CODE SECTIONS 54956.9(d)(4) & 54956.9(D)(1).**

The Committee convened in closed session at 5:08 p.m. Confidential minutes of the Closed Sessions have been prepared in accordance with the above Government Code Sections and are maintained by the Clerk of the Board in the Official Book of Confidential Minutes of Board and Committee Closed Session meetings.

CS-1 CONFERENCE WITH LEGAL COUNSEL RE ANTICIPATED LITIGATION - GOVERNMENT CODE SECTION 54956.9(d)(4)[2023-3342](#)

CONVENED IN CLOSED SESSION:

Number of Potential Cases: 1

Potential initiation of litigation regarding Miller-Holder Easement.

**CS-2 CONFERENCE WITH LEGAL COUNSEL RE EXISTING LITIGATION - [2023-3361](#)
GOVERNMENT CODE SECTION 54956.9(D)(1)**

CONVENED IN CLOSED SESSION:

Number of Cases: 2

Fernando Herrera Workers' Compensation Claim, Workers Compensation Appeals Board, Case Nos. ADJ12271396 and ADJ16380462

RECONVENED IN REGULAR SESSION.

The Committee reconvened in regular session at 5:40 p.m.

CONSIDERATION OF ACTION, IF ANY, ON MATTERS CONSIDERED IN CLOSED SESSION:

General Counsel Brad Hogin stated there was no reportable action.

OTHER BUSINESS AND COMMUNICATIONS OR SUPPLEMENTAL AGENDA ITEMS, IF ANY:

None.

BOARD OF DIRECTORS INITIATED ITEMS FOR A FUTURE MEETING:

None.

ADJOURNMENT:

Vice-Chair Gallagher declared the meeting adjourned at 5:41 p.m. to the next Regular Steering Committee meeting to be held on Wednesday, January 17, 2024 at 5:00 p.m.

Submitted by:

Kelly A. Lore, MMC
Clerk of the Board



STEERING COMMITTEE

Agenda Report

Administration Building
10844 Ellis Avenue
Fountain Valley, CA 92708
(714) 593-7433

File #: 2024-3402

Agenda Date: 1/17/2024

Agenda Item No: 2.

FROM: Robert Thompson, General Manager

SUBJECT:

PUBLIC AFFAIRS UPDATE FOR THE MONTH OF DECEMBER 2023

GENERAL MANAGER'S RECOMMENDATION

RECOMMENDATION: Recommend to the Board of Directors to:

Receive and file the Public Affairs Update for the month of December 2023.

BACKGROUND

Included in this report are recent activities of interest managed by the Public Affairs Office for the month of December 2023.

RELEVANT STANDARDS

- Maintain influential legislative advocacy and a public outreach program
- Maintain collaborative and cooperative relationships with regulators, stakeholders, and neighboring communities
- Listen to and seriously consider community input on environmental concerns

PROBLEM

The Orange County Sanitation District (OC San) is well-recognized within the water/wastewater industry; however, within our service area, as we do not have direct communications through a billing method, there may be limited knowledge by our customers of the important work we do to protect public health and the environment. In general, the customers we serve may not realize that when they improperly dispose of waste into the sanitation system, it can negatively affect our sewer lines, our treatment plants, and the quality of water we supply for the GWRS.

PROPOSED SOLUTION

By providing tours, community outreach, education, and general communication via OC San's website, social media, and direct mailings, we can share information with the community, local agencies, and businesses on our messaging such as the What2Flush program, energy production, water recycling, biosolids, and OC San's source control program. This, in turn, helps improve the quality of wastewater that is recycled or released to the ocean and the knowledge and understanding of wastewater treatment.

RAMIFICATIONS OF NOT TAKING ACTION

If OC San does not inform the community, local agencies, and area businesses about OC San, we may not have the support necessary to deliver our mission.

PRIOR COMMITTEE/BOARD ACTIONS

July 2022 - Public Affairs Strategic Plan for Fiscal Years 2022-2024 approved.

ADDITIONAL INFORMATION

Activities for the month of December 2023:

Outreach Report

An outreach report that includes tours, website, social media posts, construction notifications, speaking engagements, and more is attached to this Agenda Report.

Social Media

OC San messaging, announcements, and program updates were posted across OC San's social media platforms. Our social media handle is @OCSanDistrict.

- Facebook: 14 posts reaching 2.9k people
- Twitter: 9 posts reaching 638 people
- Instagram: 23 posts reaching 4.6k people
- LinkedIn: 2 posts and reaching 2k people

Presentations and Industry Coverage

In December, employees participated in four tours which included schools from Edison High School and Bassett Adult School, a new employee tour, and a resident tour. Staff also gave a presentation to a class of fifth graders on wastewater treatment in total reaching approximately 80 people for the month. Staff also attended the City of Huntington Beach Water/Wastewater Workshop in early December. Details can be found in the Outreach Report.

Construction Outreach Update

Outreach efforts continue for OC San construction activities throughout the service area. Projects are ongoing in Fountain Valley, Costa Mesa, Buena Park, Anaheim, and within both of our treatment plants. Website updates, email text alerts, and direct notifications continue to be distributed as the projects progress. In December, construction notifications were distributed to the Newport Beach community informing them about upcoming construction in January for the MacArthur Sewer Project.

Internal Communication

In December, there were 133 posts on the employee intranet -*The San Box*, four weekly emails distributed on relevant topics for the week, and the employee newsletter, *The Pipeline* which is published bi-monthly (distributed in the month of December).

OC San Holiday Luncheons

During the holiday season, OC San hosted a luncheon for employees to celebrate the end of a successful year. This year one main luncheon was held at Plant No. 2 where over 450 employees from both plants gathered. The EMT also served night shift employees dinners which were held during the first week of December.

Spark of Love Toy Drive

OC San employees continued to donate toys to help children in need. In partnership with the Fountain Valley Fire Department, OC San staff donated over 100 toys and nearly \$500.

Website Redesign Begins

The OC San website redesign project began earlier this month. Public Affairs and IT staff are leading the effort with Neumeric Technologies to redesign and improve the website, allowing for greater transparency and accessibility for our public. The project is scheduled for completion in late summer 2024.

Upcoming Activities for January:**OC San Celebrates 70 Years of Environmental Excellence**

2024 marks OC San's 70th anniversary. To commemorate this milestone, OC San will celebrate throughout the year by sharing historical information and achievements through online posts, videos, and social media. We will also host a Community Open House in June to celebrate this milestone. New anniversary branding was launched on January 2 and will be carried out through the year.

Headquarters Completion and Move In

The Headquarters Building is nearing completion which will soon allow staff to make the transition from Plant No. 1 to the new site. Staff is preparing for the move by coordinating with the move management consultant to ensure a smooth transfer. Move-in is planned for later in the first quarter of 2024.

Neighborhood Connection Newsletter

The quarterly newsletter is intended to keep our customers in the service area informed of the service and various initiatives led by OC San. The winter issue will include messaging on OC San's 70th anniversary, the grand opening of the Headquarters Building, and a review of our CIP projects. The newsletter is distributed electronically.

Member Agency Outreach Toolkits

On a quarterly basis, toolkits are distributed to our member agencies with messages of importance for the local community. The toolkits include articles and graphics to be used in newsletters, websites, and social media. A winter toolkit will be distributed in late January.

CEQA

N/A

FINANCIAL CONSIDERATIONS

All items mentioned are included in OC San's FY 2022-2024 Budget.

ATTACHMENT

The following attachment(s) may be viewed on-line at the OC San website (www.ocsan.gov) with the complete agenda package:

- Outreach & Media Report - December 2023

Outreach and Media Summary



December 2023

OC San Public Affairs Office

Table of Contents

OUTREACH REPORT.....	PAGE 1
FACEBOOK POSTINGS	PAGE 2
TWITTER POSTINGS	PAGE 3
INSTAGRAM POSTINGS.....	PAGE 4
LINKEDIN POSTINGS.....	PAGE 5
NEWS ARTICLES.....	PAGE 6

Outreach Report December 2023

Date	Tours	Attendees	Tour Guide
12/4/23	Edison High School	40	Jacob Dalgoff/ Pegah Behravan
12/9/23	Bassett Adult School	9	Shabbir Basrai
12/12//23	New Employee Tour	18	Tom Meregillano
12/28/23	Resident Tour	5	Cortney Light
Date	Speaking Engagements/Events	Attendees	Presenter
12/7/23	Huntington Beach Water/Wastewater Workshop		
12/20/23	Anaheim Elementary School Class Presentation	15	Mohaab Abodia
Project Area	Outreach Notifications	# of People Reached	Website Posts and Text Alerts
Anaheim/ Buena Park	Orange Western Sewer - project update		1 website posts/
Newport Beach	MacArthur Sewer Project – start of construction notice	800	1 website posts
External Communications	Distribution	# of People Reached	
5 Minutes Per Month	VVP Plan	216	
Board Member Talking Points	One	50	
Website Posts	4 posts	3.8 k views	Website
Facebook	14 posts	2.9 k reached	Social Media
Twitter	9 tweets	638 reached	Social Media
Instagram	23 posts	4.6 k reached	Social Media
LinkedIn	2 posts	2 k reached	Social Media

Post performance - Facebook Pages

Data from 01 Dec, 2023 to 31 Dec, 2023

Sources

Orange County Sanitation District

DATE ▼	POST	ENGAGEMENT RATE	IMPRESSIONS	REACH
Orange County Sanitation District Dec 31, 16:02	(Post with no description)	3.48%	115	115
Orange County Sanitation District Dec 29, 19:55	One last #FlashbackFriday before the year ends. Christmas is still fresh in our minds so we want to thank Fountain Valley Firefighters Association for being our partners for Spark of Love. And a huge THANK YOU to our team for donating so...	15.25%	241	236
Orange County Sanitation District Dec 27, 19:37	#WastewaterWordWednesday. Trickling filter: A biological secondary treatment process where bacteria and other microorganisms grow as slime on the surface of rocks or plastic media and consume nutrients in the wastewater as it trickle...	9.17%	124	120
Orange County Sanitation District Dec 21, 03:01	OC San is currently experiencing a lot of water from this storm. During heavy rains, and in the hours immediately following, the sewer lines carry significantly higher levels of water to the treatment plants due to the inflow and infiltration ...	3.36%	351	327
Orange County Sanitation District Dec 19, 21:51	It's safe to say that receiving the STAR certification from Cal/OSHA for the Volunteer Protection Program was a lengthy but very worthwhile process! Flags up for this recognition that is all thanks to our team. Visit ocsan.gov to read the...	12.81%	218	203
Orange County Sanitation District Dec 15, 23:34	When the wipes say "flushable" on them... #The3Ps #PeePoopPaper #Dontclogthethrone	12.35%	184	170
Orange County Sanitation District Dec 13, 14:03	Biosolids and our biosolids team in action! The remaining solids from our wastewater treatment process gets turned into biosolids that are then used for farming non-edible crops. #BiosolidsTeam #OCSanCareers #JobsInWastewater	9.29%	238	226
Orange County Sanitation District Dec 11, 21:34	The OC San Administration Committee meeting will be held on Wednesday, Dec. 13 at 5 p.m. and the Steering Committee Meeting (5 p.m.) and Board of Directors Meeting (6 p.m.) will be held on Thursday, Dec. 14. Click here to vie...	1.79%	63	56
Orange County Sanitation District Dec 10, 17:10	🎁 Give the gift of a clog-free home this season! Remember, when you're at home or someone else's house celebrating, you should only put pee, poop, and (toilet paper down the drain...you could save them from the surprise of a...	7.59%	707	646
Orange County Sanitation District Dec 08, 23:30	The Administration Committee Meeting is happening next week on Wednesday, Nov. 13 at 5 p.m. Click here to view the agenda:	1.92%	65	52
Orange County Sanitation District Dec 08, 16:42	Welding was done at Plant No. 1 in Fountain Valley back in the mid-1950's. There is a large variety of careers at OC San, then and now. Visit ocsan.gov/job to view open positions. #FlashbackFriday	13.33%	343	315
Orange County Sanitation District Dec 06, 18:55	The General Legal Services Ad Hoc Committee Meeting is on Thursday, Dec. 14 at 3:30 p.m. Click here to view the agenda:	0%	47	40
Orange County Sanitation District Dec 04, 22:17	This Wednesday, Oct. 6, OC San will be having the Operations Committee Meeting (5 p.m.). Click here to view the agenda:	2.33%	49	43
Orange County Sanitation District Dec 02, 21:40	OC San is looking for experts in their fields to join our team. Apply at ocsan.gov/jobs	5.17%	360	329

Post performance - Twitter

Data from 01 Dec, 2023 to 31 Dec, 2023

Sources

@OCSanDistrict

DATE ▼	POST	ENGAGEMENT RATE	ENGAGEMENTS	IMPRESSIONS
@OCSanDistrict Dec 29, 19:55	One last #FlashbackFriday before the year ends. Christmas is still fresh in our minds so we want to thank @FountainValleyFirefighters for being our partners for Spark of Love. And a huge THANK YOU to our team for donating so many...	1.1%	2	182
@OCSanDistrict Dec 27, 19:38	#WastewaterWordWednesday. Trickling filter: A biological secondary treatment process where bacteria and other microorganisms grow as slime on the surface of rocks or plastic media and consume nutrients in the wastewater as it trickle...	7.5%	3	40
@OCSanDistrict Dec 21, 03:00	OC San is experiencing higher peak flows into the plant due to this recent storm. We are asking residents to please defer using water-using chores until after the storm has passed. Thank you for your cooperation. https://twitter.co...	7.55%	4	53
@OCSanDistrict Dec 19, 21:51	It's safe to say that receiving the STAR certification from Cal/OSHA for the Volunteer Protection Program was a lengthy but very worthwhile process! Flags up for this recognition that is all thanks to our team. Visit http://ocsan.gov to re...	3.85%	2	52
@OCSanDistrict Dec 15, 23:34	When the wipes say "flushable" on them... #The3Ps #PeePoopPaper #Dontclogthethrone https://twitter.com/OCSanDistrict/status/1735805458177261672/photo/1	4.84%	3	62
@OCSanDistrict Dec 13, 14:01	Biosolids and our biosolids team in action! The remaining solids from our wastewater treatment process gets turned into biosolids that are then used for farming non-edible crops. #BiosolidsTeam #OCSanCareers #JobsInWastewat...	5.26%	3	57
@OCSanDistrict Dec 10, 17:10	🎁 Give the gift of a clog-free home this season! Remember, when you're at home or someone else's house celebrating, you should only put pee, poop, and (toilet paper down the drain...you could save them from the surprise of a...	5.08%	3	59
@OCSanDistrict Dec 08, 16:42	Welding was done at Plant No. 1 in Fountain Valley back in the mid-1950's. There is a large variety of careers at OC San, then and now. Visit http://ocsan.gov/job to view open positions. #FlashbackFriday https://twitter.com/OCSanDis...	8.62%	5	58
@OCSanDistrict Dec 02, 21:42	OC San is looking for experts in their field to join our team. Visit http://ocsan.gov/jobs to apply now! https://twitter.com/OCSanDistrict/status/1731066268621681118/photo/1	2.67%	2	75

Post performance - Instagram Business

Data from 01 Dec, 2023 to 31 Dec, 2023

Sources

ocsandistrict





DATE ▼	POST	ENGAGEMENT RATE	IMPRESSIONS	LIKES	REACH
ocsandistrict Dec 29, 19:56	One last #FlashbackFriday before the year ends. Christmas is still fresh in our minds so we want to thank @FountainValleyFirefighters for being our partners for Spark of Love. And a huge THANK YOU to our team for donating so many...	13.85%	282	25	231
ocsandistrict Dec 27, 19:38	#WastewaterWordWednesday. Trickling filter: A biological secondary treatment process where bacteria and other microorganisms grow as slime on the surface of rocks or plastic media and consume nutrients in the wastewater as it trickle...	5.98%	0	18	301
ocsandistrict Dec 27, 19:36	(No description)	0%	132	0	131
ocsandistrict Dec 25, 19:59	(No description)	0%	97	0	97
ocsandistrict Dec 22, 21:28	Listen to the Elf or he'll tell Santa 🧝	0%	120	0	118
ocsandistrict Dec 21, 03:00	OC San is experiencing higher peak flows into the plant due to this recent storm. We are asking residents to please defer using water-using chores until after the storm has passed. Thank you for your cooperation.	4.17%	0	9	216
ocsandistrict Dec 19, 21:51	It's safe to say that receiving the STAR certification from Cal/OSHA for the Volunteer Protection Program was a lengthy but very worthwhile process! Flags up for this recognition that is all thanks to our team. Visit ocsan.gov to read the...	7.08%	257	15	240
ocsandistrict Dec 15, 23:34	When the wipes say "flushable" on them... #The3Ps #PeePoopPaper #Dontlogthethrone	2.79%	193	3	179
ocsandistrict Dec 13, 23:40	(No description)	0%	120	0	120
ocsandistrict Dec 13, 23:38	Load up the 🚒 @fountainvalleyfirefighters	0%	122	0	121
ocsandistrict Dec 13, 23:37	Spark of Love with @fountainvalleyfirefighters	0%	125	0	122
ocsandistrict Dec 13, 23:36	And then we took it a step further and invited @fountainvalleyfirefighters	0%	124	0	123
ocsandistrict Dec 13, 23:34	We did a thing 🎁	0%	132	0	131
ocsandistrict Dec 13, 17:56	Idk about you, but we can't wait for the new building to be completed. Look at those lines!	0%	142	0	139
ocsandistrict Dec 13, 17:54	(No description)	0%	158	0	154
ocsandistrict Dec 13, 14:03	Biosolids and our biosolids team in action! The remaining solids from our wastewater treatment process gets turned into biosolids that are then used for farming non-edible crops. #BiosolidsTeam #OCSanCareers #JobsInWastewater	6.81%	315	16	279
ocsandistrict Dec 10, 17:10	🎁 Give the gift of a clog-free home this season! Remember, when you're at home or someone else's house celebrating, you should only put pee, poop, and (toilet paper down the drain...you could save them from the surprise of a...	6.29%	527	25	493
ocsandistrict Dec 08, 16:42	Welding was done at Plant No. 1 in Fountain Valley back in the mid-1950's. There is a large variety of careers at OC San, then and now. Visit ocsan.gov/job to view open positions. #FlashbackFriday	6.84%	290	18	263
ocsandistrict Dec 07, 21:53	Deck the halls with some Division Stockings!	0%	161	0	159
ocsandistrict Dec 07, 21:44	Get your feast on. Thanks for all our OC San server volunteers	0%	172	0	170
ocsandistrict Dec 07, 21:41	(No description)	0%	186	0	183
ocsandistrict Dec 07, 21:40	The Holidays at OC San	0%	190	0	186
ocsandistrict Dec 02, 21:40	OC San is looking for experts in their fields to join our team. Apply at ocsan.gov/jobs	6.05%	450	23	413

Post performance - LinkedIn Pages

Data from 01 Dec, 2023 to 31 Dec, 2023

Sources

 Orange County Sanitation District

DATE ▼	POST	ENGAGEMENT RATE	IMPRESSIONS	REACTIONS	SHARES
 Orange County Sanitation District Dec 19, 21:51	 <p>It's safe to say that receiving the STAR certification from Cal/OSHA for the Volunteer Protection Program was a lengthy but very worthwhile process! Flags up for this recognition that is all thanks to our team. Visit ocsan.gov to read the...</p>	9.17%	600	18	3
 Orange County Sanitation District Dec 13, 14:03	 <p>Biosolids and our biosolids team in action! The remaining solids from our wastewater treatment process gets turned into biosolids that are then used for farming non-edible crops. #BiosolidsTeam #OCSanCareers #JobsInWastewater</p>	6.38%	1,411	42	1

Media Articles for December 2023

Article	Date	Source	Link
From flush to faucet: More places look to turn sewage into tap water	12/16/2023	Oregon Capital Chronicle	https://oregoncapitalchronicle.com/2023/12/16/from-flush-to-faucet-more-places-look-to-turn-sewage-into-tap-water/
STAR Status for OC San	12/18/2023	OC San Press Release	https://www.ocsan.gov/home/showpublisheddocument/34341/638385766867702233
California approves rules that turn sewage into drinking water	12/18/2023	Cal Matters	https://calmatters.org/environment/2023/12/california-rules-turn-sewage-into-drinking-water/
How Soon Will Southern Californians Be Using Water That's Gone From Toilet To Tap?	12/19/2023	Laist	https://laist.com/news/climate-environment/toilet-to-tap-water-southern-california-timeline
Stretch of Laguna Beach coast closed due to sewage spill (not OC San related)	12/23/2023	OC Register	https://www.ocreger.com/2023/12/23/stretch-of-laguna-beach-coast-closed-due-to-sewage-spill/
2023: The Year of Orange County Water Woes	12/26/2023	OC Voice	https://voiceofoc.org/2023/12/2023-the-year-of-orange-county-water-woes/



STEERING COMMITTEE

Agenda Report

Administration Building
10844 Ellis Avenue
Fountain Valley, CA 92708
(714) 593-7433

File #: 2024-3431

Agenda Date: 1/17/2024

Agenda Item No: 3.

FROM: Robert Thompson, General Manager

SUBJECT:

LEGISLATIVE AFFAIRS UPDATE FOR THE MONTH OF DECEMBER 2023

GENERAL MANAGER'S RECOMMENDATION

RECOMMENDATION: Recommend to the Board of Directors to:

Receive and file the Legislative Affairs Update for the month of December 2023.

BACKGROUND

The Orange County Sanitation District's (OC San) legislative affairs program includes advocating for OC San's legislative interests; sponsoring legislation (where appropriate); and seeking Local, State, and Federal funding for projects and programs.

RELEVANT STANDARDS

- Maintain influential legislative advocacy and a public outreach program
- Build brand, trust, and support with policy makers and community leaders
- Maintain collaborative and cooperative relationships with regulators, stakeholders, and neighboring communities

PROBLEM

Without a strong advocacy program, elected officials may not be aware of OC San's mission, programs, and projects and how they could be impacted by proposed legislation.

PROPOSED SOLUTION

Continue to work with Local, State, and Federal officials to advocate for OC San's legislative interests. Help to create/monitor legislation and grants that would benefit OC San, the wastewater industry, and the community. To assist in relationship building efforts, OC San will continue to reach out to elected officials through facility tours, one-on-one meetings, and trips to Washington D.C. and Sacramento.

RAMIFICATIONS OF NOT TAKING ACTION

If OC San does not work with Local, State, and Federal elected officials, legislation could be passed that negatively affects OC San and the wastewater industry. Additionally, a lack of engagement may result in missed funding opportunities.

ADDITIONAL INFORMATION

2023 Legislative Year in Review:

Attached to this report is the 2023 Legislative Year in Review which includes accomplishments achieved by our Federal and State Lobbyists as it relates to OC San and our Legislative and Regulatory Plan.

ATTACHMENT

The following attachment(s) may be viewed on-line at the OC San website (www.ocsan.gov) with the complete agenda package:

- Federal Legislative Update
- Federal 2023 Legislative Year in Review
- State Legislative Update
- State 2023 Legislative Year in Review



TO: Rebecca Long

FROM: Eric Sapirstein

DATE: December 18, 2023

SUBJECT: Washington Update

The past month's legislative and regulatory activities were minimal due to the approaching holidays and end of the congressional session. Generally, the activities centered around a limited number of bills and federal agencies issuing updates on rulemakings and notices of funding opportunities. Congress will return to work January 9, 2024 for the final session of the 118th Congress. Given the approaching November elections, the opening months of 2024 are expected to set the stage for final action on fiscal year 2024 spending bills, developing fiscal year 2025 spending bills, and a host of pending issues including per- and polyfluoroalkyl substances (PFAS) clean-up and western water legislation. The following summarizes how the current congressional session concluded and the outlook for the second session.

- ***Fiscal Year 2024 Appropriations Remain to be Finalized in 2024***
For the first time in years, Congress avoided an end of year shutdown potential. It agreed to the new Speaker's approach to pass a tiered Continuing Resolution with two deadlines, splitting the twelve annual spending bills into two baskets. The first basket that includes funding for U.S. Bureau of Reclamation and U.S. Army Corps of Engineers (USACE) programs and a final spending bill must be agreed upon by January 19. The second funding deadline of February 2 includes U.S. Environmental Protection Agency (USEPA) programs that fund Community Project Requests, State Revolving Loan Fund water infrastructure, Superfund cleanups and PFAS initiatives. Absent an agreement on final spending bills within these deadlines, Congress will need to extend the short term spending deadlines or default to a year-long Continuing Resolution.

Why the Outcome of Fiscal Year 2024 Negotiations is Important to OC San

If the House, Senate and Administration are unable to reach an agreement on overall spending, known as “top line,” spending levels, the House and Senate Committees on Appropriations will lack a common budgetary baseline upon which to guide individual spending bill negotiations. This is the current situation that the committees must address in the first few days of 2024. If successful, final negotiations on individual spending bills would proceed. If, however, an overall agreement remains elusive, the prospect of Congress passing a year-long Continuing Resolution grows. If a Continuing Resolution is passed, tradition holds that new programs and projects spending, including Community Projects, would be precluded.

Fiscal Year 2025 Spending Will Challenge Congressional Priorities

On the heels of any final Fiscal Year 2024 spending agreement, Congress must almost immediately turn its attention to the Fiscal Year 2025 budget request. Under the Budget and Impoundment Control Act, the president must transmit the formal budget on the first Monday of February. Past Administrations have missed this deadline, and this year is not likely to be different given the ongoing effort to finalize Fiscal Year 2024 spending. Nonetheless, when the budget is transmitted to Congress, we anticipate that the debate will unfold targeting cutting the federal budget or at least constrain any increases the Administration might propose.

Importance of Fiscal Year 2025 Budget Debate

The Fiscal Year 2025 budget request and ensuing congressional debate is likely to heighten the political debate over how the federal government should allocate federal resources as the congressional and presidential elections unfold. Given the growing clout of fiscal hawks that are seeking reduce the deficit, and by extension the growth of the federal debt, it is an almost foregone conclusion that any final spending resolution would be delayed until a Lame Duck Session following the November 2024 that would likely be guided on which party controls Congress and the White House. For OC San, the delay in finalizing spending bills could lead to a large omnibus spending bill that might carry other legislative priorities like PFAS mandates upon wastewater treatment operators with a focus upon biosolids. However, this is purely speculative and represents a worst case scenario where policy initiatives that might not have sufficient support to pass as stand-alone measures would be attached to must pass legislation.

- ***Senate PFAS Legislation Remains A Work in Progress***

The Senate Committee on Environment and Public Works continues to develop approaches to address PFAS control and clean-up needs. Following the November meetings called to consider Comprehensive Environmental Response, Compensation, and Liability Act (CERCLA) PFAS liability policy concerns, the committee staff have continued to re-evaluate approaches to protect passive receivers from CERCLA clean-up mandates.

At this writing, no agreements have been announced and the prospect remains that the committee will redouble its efforts to secure a bipartisan agreement on legislation not later than March to allow adequate time to consider a bill before Congress recesses later in the year for the November elections.

Why the Current Senate Committee Schedule is Important

The committee schedule to consider a PFAS bill has been delayed by several times. This demonstrates the committee commitment to develop a bipartisan bill that would address PFAS passive receivers' concerns over CERCLA liability. As of this writing, the committee is facing a U.S. Environmental Protection Agency announced intention to designate PFAS as a hazardous substance under CERCLA that would trigger potential and broad liability for all entities that came in contact with PFAS. Based upon the agency's recently published regulatory agenda, the final rule to designate is scheduled for March 2024. This means that the committee (and by extension Congress) would need to complete action on a PFAS bill before March 2024 to avoid a situation where PFAS liability would become a regulatory and legal reality.

- ***Water Resources Development Act of 2024***

Both the House and Senate committees with jurisdiction over the Water Resources Development Act reauthorization (WRDA) are likely to begin developing and marking up their respective bills in Spring 2024 to ensure enough time to finalize legislation for enactment in the fall. As has been the circumstance during the past few WRDA's, this cycle's WRDA is likely to be limited to U.S. Army Corps of Engineers programs and policies, resisting efforts to attach extraneous provisions like drinking water programs.

Importance of WRDA

WRDA 2024 is expected to continue to keep the focus on making USACE focus its efforts on climate resilience when undertaking its core missions. To this end, we anticipate programs that could leverage USACE facilities to address water supply reliability and storm events will be central to the development of WRDA 2024.

- ***U.S. Environmental Protection Agency Regulatory Agenda and PFAS***

USEPA as part of a government-wide update, the Unified Regulatory Agenda, issued its priorities for rulemakings over the next six months. The agenda was published alongside the agency's second PFAS Roadmap Update. Central to the publication is the announcement that the agency will:

- issue final PFAS drinking water Maximum Contaminant Level (MCL) by January 2024;
- issue final rule to designate PFAS as a hazardous substance under CERCLA by March 2024;
- issue an Advanced Notice of Proposed Rulemaking to designate PFAS as a hazardous constituent under the Resource Conservation and Recovery Act;

- define PFAS as a chemical of special concern under the Toxics Substances Control Act and thereby eliminate any exemption from reporting PFAS emissions by manufacturers (water and wastewater explicitly exempted from any impacts); and
- conduct national survey of wastewater influent, effluent and biosolids for PFAS levels.

Importance of USEPA Schedule

While the agenda contains a number of known priorities, in total it illustrates the commitment to move expeditiously on PFAS rules and policies in the lead-up to the final months of the Administration's first term.

ENS Resources: 2023 End of Year Review

Issue	Project	Status	Value to OC San
<u>Funding</u>	Per- and polyfluoroalkyl substances (PFAS) Treatment	\$3.45 million in funding secured in Federal assistance to demonstrate Supercritical Oxidation Technology.	OC San maintains its reputation as advancing solutions to address emerging treatment needs that can lead to reduced ratepayer costs.
Build America Buy America (BABA)	Seek Clarification on BABA Compliance	Working with United States Environmental Protection Agency (USEPA) Office of Water, we provided key contacts with Region IX staff and provided USEPA HQ staff with information on OC San project and needs.	Strong relationship established with USEPA contracting staff to ensure compliance with BABA and other mandates required forms for obligation of funding.
BABA/American Iron and Steel (AIS)	Community Project Grant Assistance	Working with, and monitoring, USEPA received advanced notice that BABA SRF waiver to incorporate OC San projects funded with federal assistance.	OC San has formal commitment that its project is not subject to BABA or AIS. This clarification should expedite project implementation and reduce project costs.

Issue	Project	Status	Value to OC San
PFAS	Secure Liability Protections under Comprehensive Environmental Response, Compensation, and Liability Act (CERCLA) for wastewater and biosolids management	Working Senate Committee on Environment and Public Works, we advanced the priority for liability protections from CERCLA litigation that might be levied against public agencies. OC San took a lead position in developing letters to USEPA and Congress on the importance of preserving the polluter pays principle and to ensure that Clean Water Act is preserved as the mechanism to regulate biosolids.	The effort to deliver CERCLA liability provisions for wastewater agencies will, if enacted into law preserve the foundational principle of polluter pays and avoid frivolous litigation filed against agencies like OC San by industry to dilute clean-up responsibilities.
PFAS	Communications	Developed and worked with OC San staff on communications to congressional delegation and Senate Committee on Environment and Public Works on proposed PFAS legislation.	Positioned OC San as a leading voice on commonsense legislative approaches to ensure industrial dischargers held responsible for cleanups and that funding be provided to support treatment and monitoring needs of wastewater stakeholders.

Issue	Project	Status	Value to OC San
<u>WIPES</u>	Prevent disposal of wipes into treatment systems	Working with OC congressioinal delegation and House and Senate committees OC San provided advocacy in support of legislation to label disposable wipes to avoid flushing. Legislation pending action in House. Companion Senate legislation introduced.	Maintained OC San as leader in developing policies that will help to restrain O&M costs attributable to impacts from improper flushing on wipes.
Monitoring	Monitored funding opportunities to support OC San mission	Provided timely updates on federal procurement opportunities from Infrastructure Investment and Jobs Act and Inflation Reduction Act (IRA).	Provides OC San staff with opportunities to support investment priorities.
Build America Bonds	Monitored subsidies	Monitored budget sequestration efforts to protect subsidy payments for Build America Bonds.	Provided OC San with analysis of threats to continued availability of subsidy payments avoiding need to restructure debt.
Delegation Visit	Worked with OC San to ensure visits	Secure visit by Representative Correa to tour OC San.	Maintained strong working relationship with Rep. Correa and allowed for formal thanks for leading effort to secure Community Project Assistance.

Issue	Project	Status	Value to OC San
State of the District	Worked with OC San staff to participate in State of OC San	Secured attendance Congressional attendance at the State of OC San including Congressman Correa and staffers from various Congressional Offices.	Allowed OC San to demonstrate to congressional delegation strong local support for OC San mission
<u>Legislative Planning</u>	Worked with OC San staff and subject matter experts in updateing the Legislative and Regulatory Plan	The 2024 Legislative and Regulatory Plan was passed by the Board of Directors at the November 2023 meeting.	Provided expert legislative guidance regarding potential legislation and regulations that could have an affect on OC San.
<u>Position Letters</u>	Position letters on behalf of OC San	Provide copy and guidance regarding OC San's position. Topics included financing, PFAS and various environmental issues.	Through the service of ENS Resources and their experts, OC San is well represented in D.C. and to the various agencies that work with OC San.

MEMORANDUM

To: Orange County Sanitation District
From: Townsend Public Affairs
Date: December 20, 2023
Subject: Monthly Legislative Report

STATE UPDATES

With the Legislature adjourned until January, the month of December largely focused on looking ahead to next year. The Legislature will be returning to Sacramento the first week in January to start the second year of the current two-year legislative session.

Looking to next year, there are over 1,240 measures that did not meet specified deadlines for passage in 2023 and were held as “Two-Year Bills.” These measures will be eligible for consideration in January of 2024 and may be re-integrated into the legislative process along with other measures introduced at the beginning of the new session. Legislators will be focused in January on advancing Two-Year Bills that did not pass out of their house of origin this year.

LAO Releases Comprehensive Fiscal Outlook

On December 7, the Legislative Analyst’s Office (LAO) released its Fiscal Outlook Report for the State’s 2024-25 upcoming budget cycle. The LAO’s annual Fiscal Outlook publication provides an independent assessment of the California state budget condition for the upcoming fiscal year, along with a forecast of the State’s longer-term fiscal condition. The key takeaway from the outlook report is a **projected \$68 billion budget shortfall in the 2024-25 fiscal year**, due mostly to the net effect of unexpected revenue changes in the 2022-23 and 2024-25 fiscal years.

The conditions surrounding the 2024-25 fiscal year outlook are atypical compared to recent years’ versions, which can largely be attributed to the unprecedented delay in tax return filings generated by the severe winter storms in early January 2023. The delay caused most high earners who contribute close to half of California’s personal tax income revenue to delay tax return filings until the last minute. This meant that the Administration and the Legislature had an incomplete picture of 2023-24 revenues when they passed the budget in June. The LAO approximates that the State overallocated close to \$26 billion in the enacted 2023-24 budget.

While the budget outlook recommends fiscal prudence over the next few years, the LAO reports that the Legislature has a number of tools at its disposal to address the scope of the deficit, including \$24 billion in reserves, cost shifts, reductions in one-time spending, and reducing spending on schools and community colleges.

Looking ahead, the Governor and the Department of Finance will continue to make their own assessments of the State's fiscal condition in preparation for the release of the January budget framework proposal. As is the case with most years, the status of the State's spending plan is subject to fluctuations and could change throughout 2024 once additional tax return filings are collected and accounted for.

This could mean that the State will pull back from competitive grant programs or budget allocations to specific projects in the 2024-2025 budget cycle.

Department Of Finance Letter Directs to Immediate Budget Reduction Actions

On December 12, the California Department of Finance released a budget letter to California State Agency Secretaries regarding a current year expenditure freeze to reduce current-year General Fund expenditures. The letter cites ways to limit expenditures including limiting new goods and services contracts, reducing information technology costs, limiting vehicle replacements, limiting office supply purchases, reducing non-essential travel, cancelling some leave buy-back programs, and deferring funding requests to the State's Architecture Revolving Fund. The budget letter was released about a week after the 2024-25 Fiscal Outlook Report by the Legislative Analyst's Office (LAO) was published, which forecasts the State's upcoming budget cycle and projected \$68 billion budget shortfall in the 2024-25 fiscal year.

However, the letter does include exemptions for emergency and essential spending by authorizing agency secretaries and cabinet-level directors to make exemptions in limited instances. Which include addressing a declared emergency, providing 24-hour medical care, avoiding significant revenue losses, or achieving significant net cost savings.

Tax Ballot Measure Heads to California Supreme Court

On November 29, the California State Supreme Court granted a hearing request from Governor Gavin Newsom and Democratic Legislators to remove the Taxpayer Protection and Government Accountability Act from the November 2024 ballot. While the request to have the measure immediately removed from the ballot was denied, the Court requested written arguments from election officials and measure sponsors proving why the measure should go before the voters. The written arguments are due to the Court in mid-February 2024, which could allow for a hearing in early Spring.

The Taxpayer Protection and Government Accountability Act seeks to raise vote threshold requirements for the passage of state and local tax measures and imposes a stringent burden of proof standard that local governing bodies must meet when modifying or increasing all taxes and fees by justifying their use, need, and duration. The measure is sponsored by the California Business Round Table and its affiliates. If enacted by voters, it would make it extremely difficult for local governments to maintain existing tax and fee revenues and modify them in the future.

Townsend Public Affairs: 2023 End of Year Review

Bill Positions				
Measure	Summary	Position	Status	Value to OC San
AB 246 (Papan)	Prohibits manufacturing or selling menstrual products that have intentionally added PFAS.	Support	Governor Vetoed	Source control to reduce PFAS in influent
AB 334 (Rubio)	Establishes that an independent contractor, is not an officer for purposes of being subject to the prohibition on being financially interested in a contract.	Support	Signed	Contractors can do both the design and the construction of projects without being disqualified
AB 727 (Weber)	Prohibits manufacturing or selling cosmetic products that have intentionally added PFAS.	Support	Vetoed	Source control to reduce PFAS in influent
AB 1216 (Muratsuchi)	Requires additional fence-line monitoring system equipment for certain wastewater treatment facilities (Hyperion).	Oppose	Signed	Precedent setting for future stringent regulations
AB 1594 (Garcia)	Seeks to give additional flexibilities to public agencies for procurement of medium- and heavy-duty zero-emission vehicles.	Support	Signed	More flexibility to meet fleet electrification standards

Additional Advocacy Services		
Project/Issue	Status	Value to OC San
Association Engagement and Advocacy	TPA operates as one of the primary contacts for CASA and CSDA to advance OC San legislative positions and policies. TPA coordinates directly with Association lobbyists on bills and positions. TPA attends Association meetings on OC San's behalf and represents OC San.	TPA coordinates advocacy efforts, facilitates OC San involvement in statewide policy issues, and supports goodwill amongst other agencies statewide.
Biosolids Funding	TPA is working to get language in the Climate Bond in 2024 for a new grant program for biosolids management.	This program could provide additional funds for SCWO project.
Sales Tax Exemption for Treatment Chemicals	TPA has been meeting with the OC San legislative delegation to educate them on the issue to be ready for a bill introduction ask.	This could save OC San \$1 million per year in state sales tax.
OC San Legislative Plan	TPA met with all Subject Matter Experts (SMEs) at OC San to go over legislative priorities and funding needs.	Additional education about what OC San SME care about and how State law effects their job.
Position Letters	TPA provides draft position letters to OC San on topics including local governance, PFAS, and various environmental issues.	This allows OC San's position on key legislation to be recognized in Sacramento.
State of the District	TPA secured video for the State of the District from the Chair of the Senate Natural Resources and Water Committee - Senator Dave Min.	This improves OC San brand recognition and allows OC San to show strong leadership in the County for wastewater policy.



STEERING COMMITTEE

Agenda Report

Administration Building
10844 Ellis Avenue
Fountain Valley, CA 92708
(714) 593-7433

File #: 2023-3362

Agenda Date: 1/17/2024

Agenda Item No: 4.

FROM: Robert Thompson, General Manager

SUBJECT:

GENERAL MANAGER'S FY 2023-2024 WORK PLAN MID-YEAR REPORT

GENERAL MANAGER'S RECOMMENDATION

RECOMMENDATION: Recommend to the Board of Directors to:

Receive and file the General Manager's FY 2023-2024 Work Plan Mid-Year Report.

BACKGROUND

Each year, the General Manager prepares a work plan of activities supporting Orange County Sanitation District's (OC San) strategic goals and initiatives to be accomplished during the fiscal year. The General Manager's FY 2023-2024 work plan was received and filed by the Steering Committee and Board of Directors in July 2023. Attached is the mid-year report for the General Manager's FY 2023-2024 work plan.

RELEVANT STANDARDS

- Maintain a culture of improving efficiency to reduce the cost to provide the current service level or standard
- Plan for and execute succession, minimizing vacant position times
- Cultivate a highly qualified, well-trained, and diverse workforce
- Maintain and adhere to appropriate internal planning documents (Biosolids, Odor, and Energy Master Plans)
- Use all practical and effective means for resource recovery

PRIOR COMMITTEE/BOARD ACTIONS

July 2023 - Steering Committee and Board of Directors received and filed the General Manager's Fiscal Year 2023-2024 Work Plan.

June 2023 - Steering Committee received and filed the General Manager's Fiscal Year 2023-2024 Proposed Work Plan.

ADDITIONAL INFORMATION

The General Manager's work plan includes 21 goals for the fiscal year. Thus far, eight items in the work plan have been completed and the remainder are on track to be completed by June 30, 2024.

FINANCIAL CONSIDERATIONS

All items included in the General Manager's Work Plan are budgeted in the FY 2022-2024 Budget.

ATTACHMENT

The following attachment(s) may be viewed on-line at the OC San website (www.ocsan.gov) with the complete agenda package:

- General Manager's FY 2023-2024 Work Plan Mid-Year Report

January 17, 2024

TO: Chairman and Members of the Board of Directors

FROM: Robert C. Thompson
General Manager



SUBJECT: General Manager's FY 2023-2024 Work Plan Mid-Year Update

I am pleased to present the mid-year update for my Fiscal Year 2023-2024 Work Plan. The Work Plan has 21 individual goals organized under four Strategic Planning categories: Business Principles, Environmental Stewardship, Wastewater Management, and Workplace Environment. At the mid-year point, eight of the 21 goals have been completed and the remainder are on track for completion by the end of the fiscal year.

1. Business Principles

- **Asset Management Plan – (1)** Identify critical plant and collections assets that are currently in service and under construction that have long lead times for parts and replacement. Develop an approach to mitigate procurement risks and impacts to plant and collections resiliency under current market conditions by March 31, 2024. **(2)** Develop an approach to evaluate procurement times, market pricing, and bidding risks for projects in the design phase and adjust construction cost estimates and schedules accordingly by December 31, 2023.

UPDATE: (1) In progress. Development of major equipment list has begun with completion anticipated by March 2024. **(2) Complete.** An approach to update the design scope of work template for current and future projects was developed.

- **Permit Outreach and Restructuring –** Conduct an analysis of member agency services, encroachment permits, and requirements to better understand and evaluate if a regional approach and harmonized fee structure is needed with a determination by June 30, 2024.

UPDATE: In progress. Outreach correspondence has been transmitted, via email, to member agencies and those managing public right-of-way access. Most agencies responded indicating their current processes that are in place. The permit process of each agency including current and active encroachment permits issued or held have been documented. OC San will

request additional information from select cities to evaluate if a regional fee structure can be established.

- **Interagency Agreements for Wastewater Service** – Expand on coordination opportunities with the Irvine Ranch Water District (IRWD) in anticipation of the expiration of agreements in 2026.

UPDATE: In progress. OC San and IRWD Management have begun to meet to explore collaborative opportunities that exist between agencies. Staff will continue to meet to develop ideas for improved service delivery to bring to our Boards of Directors.

- **Pretreatment Management** – Work with member agencies to update waste discharge and pretreatment ordinance by June 30, 2024.

UPDATE: In progress. The California Regional Water Quality Control Board affirmed OC San's audit responses in November. OC San is working with member agencies and others to update their ordinances to comply with changes required.

- **Organizational Advocacy and Outreach** – Implement an integrated outreach strategy that will include industry and media coverage for the Supercritical Water Oxidation project.

UPDATE: In progress. Various presentations have been given to groups of interest and news articles published over the last six months promoting and covering OC San's innovative project. All news articles are included in OC San's monthly outreach report presented to the Steering Committee and the Board of Directors.

2. Environmental Stewardship

- **Food Waste Treatment** – Continue with a county-centric approach. Finalize the unified specifications and collaborate with OC Waste & Recycling to support the construction and utilization of a regional food waste processing facility by June 30, 2024.

UPDATE: Complete. In March, OC San met with OC Waste and Recycling (OCWR) to discuss next steps concerning OCWR's strategic initiatives for developing a regional food waste processing facility. OCWR and other OC publicly owned treatment works digester owners were provided with a

unified food waste slurry specification. A draft project MOU was provided to OCWR for consideration.

- **Urban Runoff Optimization Study** – Identify opportunities within Orange County Water District, County of Orange, and OC San's respective water, stormwater, and wastewater systems for additional dry weather urban runoff diversion under a controlled discharge scenario by June 30, 2024.

UPDATE: In progress. Initial screening criteria has been developed and the initial list of potential urban runoff diversions has been identified. Initial meetings have been conducted with future project funding stakeholders and environmental stakeholders to review potential diversion locations.

- **Energy Resilience** – *(Carried over from FY 22/23)* **(1)** Investigate energy storage options to build resilience and offer potential cost savings. Work with the consultant as part of the Energy and Digester Gas Master Plan Study and report to the Board of Directors by October 31, 2023. **(2)** Complete the Study by June 30, 2024.

UPDATE: (1) Complete. An energy resilience information item was presented to the Operations Committee on October 4, 2023, and the Administration Committee on October 11, 2023. **(2) In progress.** The project has completed a portion of the technical memorandums that are part of the overall study.

- **Fleet Long-Term Strategy** – Review and update the fleet procurement strategy based on recently adopted regulations. Regulatory compliance will work with air quality consultants to analyze California Air Resources Board's Advanced Clean Fleet Regulations and develop recommendations for fleet replacement by December 31, 2023.

UPDATE: Complete. OC San Regulatory Compliance staff has successfully engaged with California Association of Sanitation Agencies and Yorke Engineering, LLC to analyze California Air Resource Board's Advance Clean Fleet Regulations. Together with OC San Fleet Services, Regulatory Compliance has developed three viable pathways for fleet replacement. The viable pathways/recommendations will be presented to the Executive Management Team for deliberation in early 2024.

- **Headquarters Educational Display** – Develop a Board approved design for the hands-on educational display for the outdoor patio by June 30, 2024.

UPDATE: In progress. Staff continues to work with the design consultant to develop a hands-on educational display following the grand opening of the building.

- **Member Agency Outreach Program** – Develop outreach material for member agencies to educate, inform, and reduce impacts affecting the local and regional sewer system by December 31, 2023.

UPDATE: Complete. An outreach toolkit including messaging and supporting graphics was distributed to our member agencies to share with their community regarding local issues affecting the regional system.

- **Industrial Users Award Program** – Identify opportunities to expand OC San Pretreatment Honor Roll Program beyond Significant Industrial Users by June 30, 2024.

UPDATE: In progress. Staff have identified the Wastehauler Program or the Dry Weather Urban Runoff Discharge Program as potential additions to the Pretreatment Honor Roll program.

- **Plant No. 2 Process Facilities Seismic Resilience** – Evaluate the seismic vulnerabilities of Plant No. 2 flow processes (primary clarifiers, activated sludge facility, and ocean outfall piping) within the plant. Determine the required improvements to maintain dry weather flow capacity after a seismic event. Incorporate necessary upgrades into future capital improvement projects. Advertise for a Request for Proposal by June 30, 2024.

UPDATE: In progress. Staff have started developing the draft scope of work in preparation to advertise for a Request for Proposal in June 2024.

3. Wastewater Management

- **Supercritical Water Oxidization (SCWO)** – *(Carried over from FY 22/23)* Complete the commissioning and begin demonstration of the pilot project by June 30, 2024, subject to regulatory permitting.

UPDATE: In progress. The SCWO project site preparation is scheduled to be completed by the end of January with some valve actuator deliveries that are outstanding. Factory demonstration testing is ongoing and the delivery and installation of the SCWO skids by 374Water is scheduled for March 2024. Delays in the completion of the factory demonstration testing are due to needed modifications to the control software to mitigate clogging of the

reactor from residual biosolids deposits or incomplete reaction. Start-up and commissioning activities are planned for April with demonstration testing scheduled to start in June 2024.

- **Wastewater Characterization Study** – In collaboration with the Orange County Water District and regulatory agencies, conduct research to characterize changes in OC San's final effluent following completion of the Groundwater Replenishment System (GWRS). Complete initial chemical and toxicological evaluation by June 30, 2024.

UPDATE: In progress. Staff have begun profiling changes in OC San's final effluent chemistry following GWRS Final Expansion (FE). A toxicity assessment study was also initiated to evaluate the effects of GWRS FE on effluent toxicity. Initial findings are on track for completion by June 30, 2024, with the possibility of additional studies in the event that GWRS does not achieve steady state of operation until after June 30, 2024.

- **Biosolids Management** – Refresh both short and long-term hauling and management options to ensure reliability and availability of failsafe options, promote local biosolids management options, and enable compliance with Advanced Clean Fleet and Greenhouse Gas reduction regulations by June 30, 2024.

UPDATE: In progress. OC San is on track to issue a Request for Proposal (RFP) to secure professional services from qualified hauling contractors by the first quarter of 2024. This initiative seeks to ensure the ongoing adaptability, sustainability, and diversity within OC San's biosolids management program. Additionally, OC San has commenced discussions on a quarterly basis with the Los Angeles County Sanitation District to explore potential biosolids management collaborations in the region.

- **Property Management** – Ensure compliance with easement requirements and maintain unobstructed access to OC San's regional sewer line within the Miller-Holder alignment in Huntington Beach. Begin outreach and coordination efforts by December 31, 2023.

UPDATE: Complete. The outreach and coordination efforts began in August with briefings to our Board of Directors and city representatives. Individual packets of information have been prepared and delivered as of December 1 to each property owner within the identified area. Ongoing efforts will continue in alignment with the Board's authorization, the 2023 Strategic Plan, and Resolution OCSD 07-14 to ensure unobstructed access with our easements.

4. Workplace Environment

- **Scanning & Paper Reduction** – (*Carried over from FY 22/23*) Complete Scope of Work for Phase II, issue Request for Proposal, and award the contract for implementation of the trusted system in a phased approach by December 31, 2023. Complete Phase II by June 30, 2024.

UPDATE: In progress. A Purchase Order Agreement with ECS Imaging, Inc., utilizing the California Multiple Award Schedules (CMAS) Contract, was approved by the Administration Committee on November 8, 2023. ECS Imaging, Inc. is the vendor that completed the first phase of the trusted system implementation. OC San staff have started on Phase II to meet with stakeholders, identify where data is currently stored, develop folder structure, and set up metadata in Laserfiche. A kickoff meeting with ECS Imaging, Inc. took place in December 2023. The project is slightly ahead of schedule.

- **Emergency Preparedness** – Develop and conduct an earthquake emergency response drill, which includes evacuation of buildings, assembly and accountability of employees, deployment of the damage assessment team, and medical team response by June 30, 2024. Conduct National Incident Management System (NIMS) training for employees that are involved in emergency planning and response or recovery efforts by June 30, 2024. NIMS training is determined based on assignment within OC San's Emergency Operations Center (EOC). Additionally, employees will receive training on how to use the Incident Command System (ICS) forms specific to their role within the EOC.

UPDATE: In progress. Risk Management is actively planning and developing an emergency response exercise for June 2024. The exercise will simulate an earthquake that requires full building evacuation with roll call, building re-occupancy assessments, and medical team deployment. Staff assigned to OC San's EOC are actively completing prerequisite online ICS training. In-person ICS training will occur and be fully completed by June 30, 2024.

- **Centralized Training Program** – (1) OC San's employee training programs and activities will be transitioned from individual departments to Human Resources over a two-year period. The centralized approach will provide greater consistency, transparency, and access for all employees, and ensure that OC San's training is responsive to the needs of the organization

and in alignment with the Strategic Plan and General Manager's Work Plan. One new full-time employee will be dedicated to the program and will be recruited for by December 30, 2023. **(2)** Human Resources will develop training profiles based on roles, classifications, and work groups and fully transition the compliance and essential training elements by June 30, 2024.

UPDATE: (1) Complete. The full-time position for this program was filled on July 28, 2023 through a competitive recruitment, ahead of schedule. Staff collaborated to identify and vet training requirements for regulatory and OC San-mandated courses to structure training profiles specific to roles, classifications, and workgroups. **(2) In progress.** Staff continues to work towards preparing the profile master plan and updating processes including course planning, training budget requests, and fund allocation for FY 2024-25.

- **Employee Relations Legal Services** – Solicit, interview, and recommend a licensed law firm to provide as-needed legal services to support Human Resources in employment related cases by December 31, 2023.

UPDATE: Complete. The solicitation was completed and contracts were awarded by the Board of Directors in October 2023, for services to be effective beginning November 1, 2023. Contracts were awarded to Liebert Cassidy Whitmore and Payne & Fears LLP.



STEERING COMMITTEE

Agenda Report

Administration Building
10844 Ellis Avenue
Fountain Valley, CA 92708
(714) 593-7433

File #: 2023-3363

Agenda Date: 1/17/2024

Agenda Item No: 5.

FROM: Robert Thompson, General Manager

SUBJECT:

PUBLIC AFFAIRS STRATEGIC PLAN FOR FISCAL YEARS 2022-2024 MID-YEAR UPDATE

GENERAL MANAGER'S RECOMMENDATION

RECOMMENDATION: Recommend to the Board of Directors to:

Receive and file the Public Affairs Strategic Plan for Fiscal Years 2022- 2024 Mid-Year Update.

BACKGROUND

The Orange County Sanitation District's (OC San) Public Affairs Office is responsible for creating, organizing, and disseminating all internal and external communication. The primary objective of the Public Affairs team is to deliver messages that are accurate, transparent, and designed to foster trust and confidence. An integrated Public Affairs Strategic Plan is essential to effectively manage the variety of audiences served.

RELEVANT STANDARDS

- Build brand, trust, and support with policy makers and community leaders
- Maintain collaborative and cooperative relationships with regulators, stakeholders, and neighboring communities
- Make it easy for people to understand OC San's roles and value to the community
- Maintain influential legislative advocacy and a public outreach program

PROBLEM

There are various initiatives and messages that the Public Affairs Office must share with internal and external stakeholders for continued operation and efficiency of OC San. The messaging must be consistent, concise, and thoroughly planned to be efficient and effective.

PROPOSED SOLUTION

The current Public Affairs Strategic Plan includes goals, objectives, strategies, and tactics to execute the various messages and efforts set forth by OC San. The two-year plan will be in place until June 2024, with updates provided to the Steering Committee every six months.

PRIOR COMMITTEE/BOARD ACTIONS

June 2023 - Board and Steering Committee received and filed the Public Affairs Strategic Plan for Fiscal Years 2022-2024 Year-End Report.

February 2023 - Board and Steering Committee received and filed the Public Affairs Strategic Plan for Fiscal Years 2022-2024 Mid-Year Update.

July 2022 - Board and Legislative and Public Affairs Committee received and filed the Public Affairs Strategic Plan for Fiscal Years 2022-2024.

ADDITIONAL INFORMATION

OC San's Public Affairs Office Strategic Plan for Fiscal Years 2022-2024 (Plan) was developed based upon the principles of OC San's mission of protecting public health and the environment and to support the implementation of OC San's Strategic Plan. This Plan offers a vision to unify communication efforts and focus resources to achieve the greatest impact and results. The Plan consists of 11 categories. Below is a recap of the first six months of the plan.

- **Employee Communications**
Goal: Optimize communication with internal audience including those operating in the field.
 - 505 The San Box Posts (Intranet)
 - 26 Three Things to Know Emails (Weekly email)
 - Three (3) *Pipeline* issues
- **Industry Experts**
Goal: Establish and solidify OC San's reputation as infrastructure leaders in the wastewater and resource recovery industry.
 - Seven (7) awards received
 - 15 speaking engagements reaching almost 1,000 people
- **Media Relations**
Goal: Cultivate relationships with traditional and social media journalists and influencers.
 - Four (4) press releases issued
 - 350 social media posts across five platforms with average reach of 5,000
 - 1,222 new followers
- **Agency Branding and Messaging**
Goal: Enhance OC San's image and branding by utilizing proper messaging in external communication pieces such as OC San's website, presentations, digital media, and advertising, which includes maintaining a positive experience for OC San visitors.
 - Two (2) issues of Neighborhood Newsletter reaching an average of 4,500 per issue
 - Published 39 articles on the OC San website

- **Educational Outreach**
Goal: Identify and implement avenues for education and outreach within OC San's service area to promote OC San's mission and vision.
 - 41 tours reaching almost 600 people
 - Continue supporting the Heritage Museum of Orange County with their virtual and in-person teachings reaching approximately 2,500 people
 - Participated in five (5) community events reaching over 500 people

- **Capital and Maintenance Outreach**
Goal: Develop and implement outreach programs that will engage the communities affected by OC San construction and maintenance activities.
 - Four (4) printed notifications distributed reaching over 7,000 people
 - 18 electronic messages issued
 - Held individual meetings with project stakeholders

- **Legislative Affairs**
Goal: Proactive engagement in legislative advocacy efforts that could impact OC San and the wastewater industry.
 - Created annual Legislative Plan
 - Issued seven (7) State position letters and two (2) Federal position letters

- **Grant Coordination**
Goal: Monitor, track, and apply for grants available to OC San.
 - Approved for \$3.45 million in community project funding
 - Received \$40,000 grant for Headquarters Building educational display

- **Local Government Affairs**
Goal: Ensure that local elected officials, member agencies, stakeholders, and OC San Board Members are actively engaged in the work of OC San.
 - Board Member Speaking Points issued monthly
 - Developed OC San's Annual Report
 - Hosted in-person State of OC San with 150 participants
 - Six "Five Minutes Per Month" published
 - Two (2) member-agency outreach toolkits produced
 - Developed outreach program for inflow and infiltration issues within sewer service area

- **Crisis Management**
Goal: Ensure the Public Affairs Office serves as the primary spokesperson for OC San during normal business and crisis scenarios and facilitates the dissemination of information.
 - Updated Integrated Emergency Response Plan areas pertaining to the Public Affairs Office
 - Updated the Public Affairs Office's Continuity of Operations Plan

- General Manager Support
Goal: Ensure the General Manager and Assistant General Manager are supported with information necessary to communicate to the varied OC San audiences.
 - Strategic Plan update
 - Six (6) General Manager Monthly Reports
 - Monthly talking points preparation
 - Preparation of GM Work Plan Update
 - Developed material for speaking engagements and presentations

FINANCIAL CONSIDERATIONS

All items included in the Public Affairs Strategic Plan FY 2022-2024 are budgeted in the FY 2022-2024 Budget.

ATTACHMENT

The following attachment(s) may be viewed on-line at the OC San website (www.ocsan.gov) with the complete agenda package:

- Public Affairs Strategic Plan, FY 2022-2024

PUBLIC AFFAIRS
STRATEGIC PLAN

2022-2024



Public Affairs Strategic Plan FY 2022–2024

Introduction

The Orange County Sanitation District's (OC San) Public Affairs Office (PAO) is responsible for creating, organizing, and disseminating all internal and external communication. The primary objective of the PAO is to deliver messages that are accurate, transparent, and designed to foster public trust and confidence. An integrated Public Affairs Strategic Plan is essential to deal effectively with the variety of audiences we serve.

The PAO staff provides services and tools and implements programs to meet the communication needs of several audiences for OC San. This includes planning and implementing media relations; website and intranet site content; construction outreach; elected officials and government relations; internal communications, education, and outreach; and graphic development.

The PAO has created a Strategic Plan for Fiscal Years 2022 - 2024. This Plan is developed based upon the principles of OC San's Mission of protecting public health and the environment and will support the implementation of OC San's Strategic Plan. This Plan offers a vision to unify our communication efforts and focus resources to achieve the greatest impact and greatest results. This plan was created as we are in the process of recovering and moving into our new normal post the COVID-19 pandemic. At the creation of the previous PAO Strategic Plan, it was impossible to project the length of time that COVID-19 would impact our lives and operations, as such some items are carrying over to this new plan. Because much of what is planned and created by this group is based on external factors and therefore outside of our control, flexibility and fluidity is integrated into the plan. The PAO will follow the guidance set forth by management and the Board of Directors to carry out OC San's messaging and support our member agencies.

Background Information

OC San represents 20 cities, 4 special districts and a portion of the unincorporated County of

Orange. This area represents a community of 2.6 million people with approximately 550,000 customer accounts.

Unlike most public agencies where there is direct contact with customers, at OC San, billing occurs through the County of Orange property tax bills. Therefore, OC San must work through other means to communicate with the public and the rate payers. We have a 25-member Board of Directors, and over 600 employees within six departments with various goals and objectives. While these groups work independently on a variety of projects, the goal of the PAO is to provide support and messaging that is consistent throughout the agency so that we are one voice, representing the same overall goals, and portraying the same brand.

While there are many challenges with serving such a large and diverse customer base, there are also great opportunities working through the strategies laid out in this Plan.

Public Affairs Team

The division is staffed with six full-time employees and overseen by a manager.

- **Jennifer Cabral**, Administration Manager
- **Daisy Covarrubias**, Principal Public Affairs Specialist
- **Rebecca Long**, Senior Public Affairs Specialist
- **Kelly Newell**, Public Affairs Specialist
- **Belen Carrillo**, Public Affairs Specialist
- **Gregg Deterding**, Graphics Designer
- **Cheryl Scott**, Administrative Assistant

Each of these team members carry out specific functions to meet the communication goals and objectives laid out in this Plan.

Situation Analysis

- The world is attempting to recover from a pandemic and return to a sense of normalcy, though identifying what - that remains to be seen. However, OC San has been able to continue with its operations and meet the mission of protecting public health and the environment.
- While operations continue for OC San, the business functions have been modified to meet the health and safety guidelines established.
- To ensure the safety of our critical on-site staff, approximately 50 percent of staff have been working remotely for the last two years. As stability with the health crisis is reached, telecommuting staff is beginning to return on-site. Communication methods have and will continue to address the varied audiences, work schedules and work environments to maintain open and transparent communications.
- OC San is concluding a five-year rate program, with a rate study about to begin. Public communication must factor in the financial impacts to the OC San rate payers as decisions and communication is made regarding proposed fees for the next five years.
- OC San has seen a high number of retirements this year resulting in significant personnel movement and new hires. Communicating OC San's culture and reinforcing the importance in relationships are essential to the effectiveness and functionality of the agency.
- OC San experienced high turnover in the Board of Directors in 2021. Continuous engagement with the Board Members is critical for the success of this agency.
- As an essential service, OC San has continued to execute the Capital Improvement Program (CIP) to keep the regional projects on schedule that are enhancing the regional sewer system throughout the service area. In the next two fiscal years, OC San plans to award 28 construction contracts worth a total of \$400 million.
- In partnership with the Orange County Water District, OC San is constructing facilities to complete the final expansion of the Groundwater Replenishment System (GWRS). Once completed, OC San will be able to recycle 100 percent of the reclaimable flow and allow GWRS to produce enough water for 1 million people.
- OC San is constructing a new administrative headquarters building in the City of Fountain Valley across the street from Plant No.1. The project will allow OC San to consolidate administrative staff into one building thus creating additional space for process facilities in the plant. The building is designed to be welcoming and inviting to the public. The main entry plaza will feature educational exhibits highlighting OC San's mission of protecting public health and environment.

Mission

The Public Affairs Office is committed to communicating information about OC San in a timely, accurate and accessible way to the employees, the Board of Directors, our member agencies, the public, and the news media.

- We are committed to open, honest, clear, and respectful two-way communication with our audiences.
- We are dedicated to informing others about how OC San serves the public and protects the environment.
- We are committed to outstanding customer service by responding to requests quickly and efficiently.
- We are dedicated to teamwork and collaboration as well as being creative and taking the initiative to be out in front of issues.

Audiences

This Public Affairs Plan focuses largely on four primary audiences.

- **Internal**

- Board of Directors
- Executive Management Team
- Employees
- Retirees

- **The Public**

- Ratepayers
- Member Agencies
- Residents, Businesses, Commuters Impacted by OC San Construction and Maintenance
- OC San Neighbors near our facilities (plants and pump stations)
- Schools and Students
- Tour Groups

- **Industry**

- Water/Wastewater Agencies
- Trade Organizations
- Trade Media

- **Influential Public**

- Local, State, and Federal Elected Officials
- Environmental Groups
- Local Media

- OC San is dedicated to exceeding wastewater quality standards used for resource recovery.
- OC San is committed to proper planning to ensure that the public's money is wisely spent.
- OC San's assets are monitored and evaluated regularly to ensure top performance and timely replacement.
- OC San values communicating our mission and strategies with those we serve and all other stakeholders.
- Providing reliable, responsive, and affordable services in line with our customer needs and expectations is a top priority for OC San.
- OC San focuses on creating the best possible workforce where safety, productivity, customer service, and training are a top priority.
- OC San has worked very hard to create an integrated planning environment which begins with the expectations of its Board of Directors and flows down to the work product of each employee. We have worked hard to assure our staff members are communicating and providing transparent services to each other in support of the plan.
- OC San has developed an integrated Planning/Asset Management system that allows for intentional, thoughtful decision making to maintain current operations while adding resilience and meeting new challenges.
- OC San has an organizational structure with informal relationships between employees that allow for collaboration toward common goals.

Agency Key Messages

- OC San is committed to protecting public health and the environment by providing effective wastewater collection, treatment, and recycling.
- OC San is more than a wastewater treatment facility; we are a resource recovery facility making use of all our byproducts.

Public Affairs' Goals for Fiscal Year 2022/23 and 2023/24

1. Optimize communication with our internal audience including those operating in the field.
2. Continue to build OC San's reputation as infrastructure leaders in the wastewater and resource recovery industry.
3. Cultivate relationships with traditional and social media journalists and influencers to promote OC San's programs and initiatives.
4. Enhance OC San's image and branding by utilizing proper messaging in external communication pieces such as OC San's website, presentation, digital media, and advertising. Maintain a positive experience and image for our visitors.
5. Identify and implement avenues for education and outreach within OC San's service area to further promote OC San as a resource recovery agency, promote OC San's mission and promote career opportunities within the wastewater industry.
6. Develop and implement outreach programs that will engage the communities affected by OC San's construction projects.
7. Ensure proactive engagement in legislative advocacy efforts that could impact OC San and the wastewater industry.
8. Monitor, track, and apply for grants available and that make business sense to OC San.
9. Ensure that local elected officials, member agencies, stakeholders, and OC San Board Members are actively engaged in the work of OC San.
10. Ensure the Public Affairs Office serves as the primary spokesperson for OC San during normal business and crisis scenarios and facilitates the dissemination of information.

To achieve these goals, the PAO presents the following strategies and tactics, along with the primary staff assigned to that area. While individual staff members are the key contacts for each of the goals, the team works collectively and collaboratively, reflecting our core values. Our staff recognizes the key role we play at OC San, not only communicating information, but also teaching and consulting others and serving as a resource to our Board of Directors, employees, the wastewater industry, and our member agencies.

As we navigate through the pandemic recovery efforts, the team will follow this plan, and make necessary modifications to effectively communicate OC San's strategic direction. Flexibility is implemented into this plan to deal with the dynamic situation we are all in.

Public Affairs Strategies and Tactics

1. Category: Employee Communication

Program Manager: Rebecca Long

Program Coordinator/Support: Kelly Newell, Belen Carrillo, Gregg Deterding, and Cheryl Scott

Goal (what): Optimize communication with our internal audience including those operating in the field.

Objective (measure): Create employee engagement by utilizing the identified communication methods to share agency wide messages.

Strategy (why): We value open and honest communication with our employees. PAO is committed to various efforts aimed at keeping OC San employees informed about important topics, increasing the overall quality of communications to our employees while tying the business aspects of the agency with the human-interest side.

Tactics (how):

- Keep information on The San Box homepage current, relevant, and useful for OC San employees by working with the various departments to gather information that should be shared.
- On a regular basis, staff will continue to support various departments with their communication and outreach needs.
- PAO will produce six Pipeline newsletters per year with a goal of circulation by the third week of the publication month.
- PAO will track Volunteer Incentive Program (VIP) points for all participating employees and coordinate the VIP appreciation celebration.
- Create employee recognition and celebratory events throughout the year that comply with health guidelines, this may include small in-person gatherings and virtual events. To include but not limited to the Annual Holiday Lunch, the Harvest Festival, and VIP Celebration, etc.
- Commemorate OC San's achievement of reusing 100 percent of the reclaimable flow upon completion of the Groundwater Replenishment System's Final Expansion. Celebrate the milestone and acknowledge the accomplishment with staff and stakeholders.
- Continue with the Honor Walk program which acknowledges retired staff and past Board Members for their contribution to OC San. The recognition event will be hosted every other year starting in 2023.
- Write and coordinate the 3 Things to Know email blast to be distributed to all staff each Monday.
- Produce monthly Digester bulletin.
- Support and promote OC San "U", OC San's training program.

2. Category: Industry Experts

Program Manager: Daisy Covarrubias

Program Coordinator/Support: Kelly Newell, Gregg Deterding, and Cheryl Scott

Goal (what): Establish and solidify OC San's reputation as infrastructure leaders in the wastewater and resource recovery industry.

Objective (measurable): Increase participation in strategic organizations through conferences, networking activities and awards by five percent.

Strategy (why): To build positive public perception and confidence among our various audiences.

Tactics (how):

- Encourage participation and presentation in conferences
- Encourage and support award application submittals
- Publicize and coordinate award acceptance logistics
- Track all awards won by OC San by keeping a master list
- Track and promote staff abstracts, and publications

3. Category: Media Relations

Program Managers: Daisy Covarrubias and Rebecca Long

Program Coordinators: Kelly Newell, Belen Carrillo, Gregg Deterding, and Cheryl Scott

Goal (what): Cultivate relationships with traditional and social media journalists and influencers.

Objective (measurement): Increase media coverage with positive stories about OC San.

Strategy (why): While a presence in the community is important to putting a face to our agency, media (traditional and social) is equally important with a broader reach and a more direct line of communication.

Tactics (how):

- Annually update media list to stay current and fresh.
- Develop a press kit to be online and interactive.
- Build a calendar of news release topics of interest to the public and stakeholders
- Invite media for a facility tour (virtual or small group). – Rolling over to new plan as unable to complete due to COVID—19 restrictions.
- Develop media strategies for important events, decisions, or actions. e.g. CIP Campaign (see details in Category 6: Capital and Maintenance Outreach.
- Conduct media training for Board leadership, EMT and key staff members. - Rolling over to new plan as unable to complete due to COVID—19 restrictions.
- Weekly (3-5 times) social media posts about the happenings at OC San with focus on OC San's accomplishments and mission.
- Continue with social media campaigns #OCSanAtWork, #What2Flush, and those currently supporting ongoing efforts.

4. Category: Agency Branding and Messaging

Program Manager: Daisy Covarrubias

Program Coordinators/Support: Gregg Deterding, Kelly Newell, and Cheryl Scott

Goal (what): Enhance OC San's image and branding by utilizing proper messaging in external communication pieces such as OC San's website, presentations, digital media, advertising, which includes maintaining a positive experience for OC San visitors.

Objective (measure): Continue with OC San's branding campaign including updating collateral material, signage, and promotional material as appropriate and as it is used. Maintain the lobby(s) current and informative with relevant information, i.e., displays, awards case, etc.

Strategy (why): A cohesive voice, message, look, and feel are critical to the public perception that an organization holds with its community. A positive and pleasant in-person experience reinforces OC San's culture and core values as well as showcasing OC San as industry leaders, and a well-run organization, leaving behind the stigma of typical government agencies.

Tactics (how):

- Develop new website to better meet the information needs of our visitors while meeting accessibility standards.
- Maintain website accuracy, relevancy and timeliness with new stories posted weekly.
- Provide presentations, consultation, and advice on the branding and image of OC San.
- Develop new collateral materials around the key messages.
- Explore advertising options to inform the public of agency efforts and role in enhancing the local economy.
- Fulfill all requests for graphics, photos, and logos.
- Continue with online community newsletter. Increase reach and distribution list.
- Develop a branding plan for the new Headquarters Building.
- Develop an educational display in the headquarters building to illustrate OC San's reuse and recycling efforts in support of the environment and public health. Display to be revealed when new building is unveiled.
- Maintain the lobby wall in the administration building at Plant No. 1 and the Operations Center at Plant No. 2 with OC San's current branding and messaging.

- Rotate flags on light poles at Plant No. 1 and at Plant No. 2 on a biennial basis.
- Keep the award display cabinet up to date by rotating awards.
- Keep the retiree display in the Administration Building hallway up to date. On an annual basis collect the names of the retirees and update the display board.
- Maintain and coordinate the installation of Honor Walk bricks on a biennial basis.
- Display collateral material in a neatly and organized manner displayed with current and relevant information.
- Develop a video library of OC San programs to utilize as educational and promotional tools.
- Promote the development and implementation of OC San's permittee awards program that recognizes industries for improving their adherence to excellent standards.
- Support and promote the development of an awards program for biosolids truck drivers.
- Develop a campaign to showcase OC San's diversity to be launched internally and externally.

5. Category: Educational Outreach

Program Manager: Rebecca Long

Program Coordinators/Support: Kelly Newell, Belen Carrillo, Gregg Deterding, and Cheryl Scott

Goal (what): Identify and implement avenues for education and outreach within OC San's service area to promote OC San's mission and vision.

Objective (measurement): Create and identify new educational opportunities including virtual events and webinars to promote and educate the community on OC San's work and the essential service provided. Incorporate the GWRS messaging to increase awareness of the benefits to our service area.

Strategies (why): To further promote OC San as a resource recovery agency, promote OC San's mission and promote career opportunities within the wastewater industry.

Tactics (how):

- Execute the Inside the Outdoors contract for Fiscal Year 2022-2023 to continue the educational partnership that includes the Sewer Science program to 500 students within Orange County and introduce them to OC San's virtual tour program.
- Reinstate physical plant tours and continue offering the virtual tour to increase the reach of OC San's tour program.
- Identify 10-12 community event opportunities for OC San to participate in to inform and educate the community on the important role OC San plays in public health and the environment.
- Continue to encourage and promote the Volunteer Incentive Program to have a pool of staff that volunteer for events and speaking engagements that OC San participates in.
- Expand OC San's speaker's bureau to provide a wider set of speakers available.
- Public Service Announcement (PSA) Contest – work with high schools in our service area to create a promotional PSA for OC San on a biennial basis. Obtain a minimum of 20 individual and/or group entries.
- Continue hosting Wastewater 101 Citizen Academy for our ratepayers, and influential public to showcase OC San operations and initiatives. Host a minimum of four (4) series per year.
- Support the Heritage Museum of Orange County's educational efforts by supplying material to be used for virtual and in-person teaching of OC San's key messages.

6. Category: Capital and Maintenance Outreach

Program Managers: Daisy Covarrubias and Tanya Chong from Engineering,

Program Coordinators/Support: Belen Carrillo, Kelly Newell, Gregg Deterding, Cheryl Scott, and Jennifer Wein from Engineering

Goal (what): Develop and implement outreach programs that will engage the communities affected by OC San construction and maintenance activities.

Objective (measurement): Develop, implement, and provide outreach support for over 15 capital projects scheduled to break ground in fiscal years 2022/2023 and 2023/2024 in more than 10 cities.

Strategy (why): Form a positive presence in the community prior to the start of construction projects or maintenance activities that is personal and proactive. Provide impacted community with information ahead of construction activities. Inform them of the benefits and need for the project to gain support and understanding of the necessary construction.

Tactics (how):

- Proactively offer briefings and community meetings to impacted neighborhoods, civic groups, businesses, schools, churches, and other institutions within the project area on an as needed basis.
- Explore the option of placing advertising pieces in communities/areas impacted by construction.
- Respond to inquiries within a 24-hour period.
- Provide project description and notifications to impacted residents at least two weeks before construction begins.
- Update collateral materials, fact sheets and website with current construction information on an as needed basis.
- Maintain ongoing communications with city staff and Board Members on current and upcoming construction outreach projects in affected cities.
- Maintain ongoing communications with impacted residents within the project area through collateral material (e.g., flyers, door hangers, emails, text alerts, social media posts, etc.).
- Measure customer satisfaction through a construction outreach survey to be distributed at the close of construction programs.
- Support the Vendor Outreach Program to promote OC San business opportunities with local businesses.

7. Category: Legislative Affairs

Program Manager: Rebecca Long

Program Coordinator/Support: Kelly Newell, Gregg Deterding, and Cheryl Scott

Goal (what): Proactive engagement in legislative advocacy efforts that could impact OC San and the wastewater industry.

Objective (measure): Continue positive relationships with local, state, and federal officials through facility tours, meetings, and bill tracking as stated in the Legislative Plan.

Strategy (why): Legislative advocacy is an important aspect of our business. Having relationships and being actively involved, providing input and OC San's perspective on potential legislature can and does directly affect OC San and our business.

The PAO is responsible for executing the Board approved Legislative Plan, which is updated on an annual basis. In addition, staff is responsible for tracking state and federal legislation, managing OC San's legislative advocates, and seeking appropriations and grants.

Tactics (how):

- Develop and implement Annual Legislative Plan in the second quarter of each fiscal year.
- Track bills and maintain a priority list of key legislation.
- Provide regular updates to the Legislative and Public Affairs Committee on state and federal matters.
- Host legislative tours.
- Engage in Advocacy Days in Sacramento and Washington DC once a year.
- Take positions on bills that could affect OC San or the industry.
- Work with industry organizations on state and federal issues to ensure OC San's positions are communicated.
- Partner with industry organizations to co-host virtual events and activities.
- Manage the legislative advocates' contracts and facilitate regular communication between lobbyists, staff, and the Board of Directors.

8. Category: Grants Coordination

Program Manager: Rebecca Long

Program Coordinator/Support: Kelly Newell, Gregg Deterding, and Cheryl Scott

Goal (what): Monitor, track, and apply for grants available to OC San.

Objective (measure): Apply and obtain grants for qualified OC San projects and programs.

Strategy (why): Outside funding is important in moving OC San projects and programs forward. With ongoing attention to government spending, it is vital for OC San to apply for and secure grants to offset costs when available.

Tactics (how):

- Apply for two grants a year based on availability.
- Ensure Grant Policy is updated and current.
- Research grant opportunities and report out to the Legislative and Public Affairs Committee.
- Seek out available grant funding opportunities for OC San and its various divisions.
- Secure letters of support.
- Publicize grant awards received.
- Create and measure outcomes.

9. Category: Local Government Affairs

Program Manager: Daisy Covarrubias

Program Coordinators/Support: All PAO staff

Goal (what): Ensure that local elected officials, member agencies, stakeholders, and OC San Board Members are actively engaged in the work of OC San.

Objective (measure): Provide at least two communication tools per month

Strategy (why): Keeping OC San's influential public engaged in OC San's projects and accomplishments are critical to the support and success of our agency.

Tactics (how):

- Provide Board of Directors with speaking points following every OC San board meeting that can be used when reporting back to their respective councils and community groups.
- Support an orientation (as needed) for new Board members.
- Develop and keep a current list of monthly informational presentations.
- Maintain an informational presentation video library for the Board of Directors on key agency topics.
- Provide regular reports to the Legislative and Public Affairs Committee.
- Develop OC San's Annual Report.
- Publish a Five Minutes Per Month, each month.
- Participate in government affairs committees.
- Invite new council and board members within OC San's service area to take a tour of OC San and offer presentations to their respective agencies on OC San programs and efforts.
- Create and distribute quarterly outreach tool kits for member agency PIOs to help them easily share and disseminate information about OC San.
- Host a "State of the District" event for influential leaders throughout the infrastructure and water/wastewater industry, including virtual option.
- Develop an outreach program for member agencies regarding inflow and infiltration issues within their sewer systems. The program will aim to educate, inform, and reduce inflow and infiltration affecting the local and regional sewer system.

10. Category: Crisis Management

Program Manager: Rebecca Long

Program Coordinators/Support: All PAO Staff

Goal (what): Ensure the PAO serves as the primary spokesperson for OC San during normal business and crisis scenarios and facilitates the dissemination of information.

Objective (measure): Ensure that the PIOs in the PAO can respond in a crisis. Provide the necessary tools and material to follow established protocols and support the situation as needed.

Strategy (why): It is imperative during a crisis that OC San be proactive and provide clear and effective messaging to employees, public, and the media.

Tactics (how):

- Maintain an updated crisis communication plan including regular briefings with staff to identify possible issues and responses.
- Maintain and update PAO's Continuity of Operations Plan (COOP).
- Work with Risk and Safety Management on Public Affairs' role in an emergency, including our role via the Integrated Emergency Response Plan.
- Ensure proper procedures are in place for Board, employees, and public notification.
- Maintain updated contact lists for resource, member, and partnering agencies to coordinate and assist during crisis.
- Develop protocols on everyday PAO tasks to facilitate the operations of the group in a time of crisis.

11. Category: General Manager Support

Program Manager: Daisy Covarrubias

Program Coordinators/Support: All PAO Staff

Goal (what): Ensure the General Manager and Assistant General Managers are supported with information necessary to communicate to the varied OC San audiences.

Objective (measure): Develop monthly communication pieces on behalf of the General Manager. Ensure General Manager (or designee) is participating and involved in promoting OC San's initiatives.

Strategy (why): Collaborate with the General Manager to prepare communication and messaging that reflects the mission and vision of OC San.

Tactics (how):

- Assist the General Manager and the Assistant General Managers with keeping the Board Members informed and up to date with OC San activities.
- Assist in the development of the General Manager's Monthly Report.
- Develop talking points for Board and Committee meetings.
- Develop material and speaking points for presentations and speaking engagements.
- Support the development of the OC San Strategic Plan.
- Assist in the development of the General Managers Annual Work Plan, including mid-year and end of year reports.
- Manage Ask the GM questions submitted.
- Coordinate and support VIP tours guided by General Manager and Assistant General Managers.
- Coordinate and produce two Town Hall meetings (live and/or pre-recorded) to keep employees informed and engaged.

Closing Comments

This plan is a broad outline of the Public Affairs Office program. As new issues arise, new functions and duties will evolve as well. The role of the Public Affairs Office is to stay ahead of issues, be responsive and flexible to meet the needs of the agency. We will adjust our program accordingly.

New Tactics Introduced

- Vendor Outreach Program
- Inflow/Infiltration Member Outreach Campaign
- OC San New Website
- Biosolids Driver Rewards Program
- Permittee Awards
- Diversity Campaign
- Heritage Museum Educational Program
- Video Library



Public Affairs Division
10844 Ellis Avenue
Fountain Valley, CA 92708



STEERING COMMITTEE

Agenda Report

Administration Building
10844 Ellis Avenue
Fountain Valley, CA 92708
(714) 593-7433

File #: 2024-3405

Agenda Date: 1/17/2024

Agenda Item No: 6.

FROM: Robert Thompson, General Manager
Originator: Mike Dorman, Director of Engineering

SUBJECT:

REIMBURSEMENT AGREEMENT FOR ORANGE COUNTY SANITATION DISTRICT MANHOLE FRAME AND COVER ADJUSTMENTS ON PACIFIC COAST HIGHWAY IN THE CITY OF NEWPORT BEACH

GENERAL MANAGER'S RECOMMENDATION

RECOMMENDATION: Recommend to the Board of Directors to:

Approve the Reimbursement Agreement with the City of Newport Beach titled "Reimbursement Agreement (Orange County Sanitation District Manhole Adjustment)" for an amount not to exceed \$689,699 for Orange County Sanitation District manhole frame and cover adjustments on Pacific Coast Highway in the City of Newport Beach in a form approved by Special Counsel.

BACKGROUND

Caltrans is performing street improvements on the Pacific Coast Highway from the Santa Ana River to Jamboree Road in the City of Newport Beach for a total bid amount of \$10,440,096. This project generally consists of asphalt pavement resurfacing and associated improvements within the existing right-of-way. The City of Newport Beach (City) and the Orange County Sanitation District (OC San) are responsible for adjusting the elevation of their existing manholes and valve boxes within the public right of way to maintain road safety and system function.

RELEVANT STANDARDS

- Protect OC San assets
- Maintain collaborative and cooperative relationships with regulators, stakeholders, and neighboring communities
- Ensure the public's money is wisely spent

PROBLEM

OC San owns 103 manholes and 15 valve boxes within the limits of the Caltrans work area. These manholes and valve boxes require adjustment to a final grade after the pavement is resurfaced to maintain road safety and sewer accessibility. The City also has similar utility access points that must also be adjusted for the Caltrans work.

PROPOSED SOLUTION

Perform the adjustment work as a combined project with the City, separate from the Caltrans project. Enter into a reimbursement agreement with the City to have them execute the project. OC San will provide the manhole frames and covers to the City and perform inspection services to ensure the construction is in conformance with OC San standards. It is anticipated that work will begin in September 2024.

TIMING CONCERNS

The Caltrans work impacting OC San’s assets is expected to begin in September 2024.

RAMIFICATIONS OF NOT TAKING ACTION

If OC San takes no action, manhole frames and covers may be damaged, buried, or uneven with the finished road surface after the completion of the Project. These scenarios pose safety hazards for public drivers.

If OC San decides to publicly bid and perform the work at a later date, it is likely to cost more, access to some OC San facilities may be reduced until the work is complete, and there will be additional street closures that would impact the public.

PRIOR COMMITTEE/BOARD ACTIONS

N/A

ADDITIONAL INFORMATION

To efficiently execute and coordinate the adjustment work and minimize the impact to the public, the City and OC San agreed to execute a combined project. The City will manage the execution of the project and will coordinate inspections with OC San.

The City advertised Invitation No. 9417-1, West Coast Highway Joint Manhole and Valve Adjustments Project, for bids on November 15, 2023, and four sealed bids were received on December 13, 2023. A summary of the bid opening follows:

Engineer’s Estimate	\$ 1,026,000
<u>Bidder</u>	<u>Amount of Bid</u>
R.J. Noble Company	\$ 922,925
All American Asphalt	\$ 1,154,100
Teichert Energy & Utilities Group, Inc.	\$ 1,424,840
Manhole Adjustment Inc.	\$ 3,468,550

OC San’s reimbursement amount of \$689,699 includes OC San’s portion of the work, a 5% management fee for the City to manage the project, and a 20% construction contingency (consistent with the City’s approach) to account for unknown conditions that may be discovered during performance of the work.

CEQA

CEQA compliance falls under the City's project.

FINANCIAL CONSIDERATIONS

This recommendation will be funded under the Repairs and Maintenance line item for the Operations and Maintenance Department Fiscal Years FY 2024-2025 budget, which will be approved by the Board in June 2024. No work will be completed until the approval of the OC San 2024-25 Operating Budget in June 2024.

ATTACHMENT

The following attachment(s) may be viewed on-line at the OC San website (www.ocsan.gov) with the complete agenda package:

- Reimbursement Agreement

**REIMBURSEMENT AGREEMENT
(ORANGE COUNTY SANITATION DISTRICT MANHOLE ADJUSTMENT)**

THIS REIMBURSEMENT AGREEMENT FOR UTILITY ADJUSTMENT (this “**Agreement**”) is entered into the _____ day of _____, 20__ (“**Effective Date**”), between **Orange County Sanitation District**, a California public body (“**OC San**”), and **City of Newport Beach**, a California municipal corporation and charter city (“**City**”), individually referred to as “**Party**” and collectively “**Parties**”.

RECITALS

A. Caltrans proposes improvements to Pacific Coast Highway from Santa Ana River Bridge to Jamboree Road, which work will generally consist of asphalt concrete pavement resurfacing and associated improvements within the existing right-of-way. City is to adjust all of City’s structures to finished surface that are in locational conflict with Caltrans’ proposed improvements (“**City Project**” or the “**Project**”).

B. OC San has surficial manhole structures (the “**Utilities**”) located on Pacific Coast Highway that are also in locational conflict with Caltrans’ proposed improvements and that will similarly have to be adjusted to finished surface (the “**Adjustment Work**”).

C. In order to minimize impacts to the environment, community and surrounding areas, City agrees to perform the Adjustment Work as part of its Project subject to reimbursement from OC San.

D. City and OC San desire to enter into this Agreement to outline their respective obligations regarding the cost, reimbursement, and timely execution of the Adjustment Work by City.

E. OC San has provided City with a copy of all OC San standard drawings (“**Standards**”) outlining the Adjustment Work to be performed, and a copy of which Standards are attached hereto and made a part hereof as **Exhibit A**.

AGREEMENT

For and in consideration of the foregoing recitals which are incorporated herein, and other good and valuable consideration, the receipt and sufficiency of which are hereby acknowledged, City and OC San agree as follows:

Section 1: **Recitals.** The Recitals above are deemed true and correct, are hereby incorporated in this Section as though fully set forth herein, and each Party to this Agreement acknowledges and agrees that they are bound by the same.

Section 2: **Elements of Agreement.** City and OC San will work cooperatively together so that Adjustment Work can be constructed as part of the Project in a manner that minimizes the

costs and impacts to all Parties and the public. The specific terms and conditions governing the elements of this Agreement are set forth hereinafter.

Section 3: CITY's Specific Obligations.

- A. City will be responsible for compliance with the California Environmental Quality Act ("CEQA") and all other permitting requirements.
- B. City will undergo a Public Works bidding process and will enter into a construction contract that includes the Adjustment Work as part of the Project. The Adjustment Work shall be constructed in accordance with the Standards. The total estimated cost of the Adjustment Work is \$656,856, which includes a 20% contingency for unforeseen work not included in Project bid documents. The amount to be reimbursed by OC San shall be based on the actual cost of the Adjustment Work, subject to the prior written approval of OC San.
- C. After award of the construction contract, City will submit relevant documentation to OC San for its files.
- D. For the duration of Project construction, City will:
 - 1. Promptly inform OC San of any proposed changes to the construction contract as it relates to the Adjustment Work. Copies of proposed changes affecting the Adjustment Work will be provided to OC San within five (5) working days of submission to City.
 - 2. Provide OC San staff with contractor schedules and updates within five (5) days of acceptance by City staff.
 - 3. Invite OC San staff to construction progress meetings.
 - 4. Notify OC San 72 business hours prior to the need for an inspection.
 - 5. Ensure the City's construction contractor coordinate with OC San to retrieve the manhole frames and covers for the Utilities (provided by OC San) from the OC San Treatment Plant No. 2 in Huntington Beach.
- E. City will document and inform OC San of the date of the completion of the Adjustment Work. City will verify with OC San prior to issuance of progress payment to City's construction contractor that Adjustment Work was completed per the Standards.
- F. City shall not be obligated to perform any Adjustment Work in excess of \$656,856 unless OC San increases the Reimbursement Amount in accordance with Section 4.D.

Section 4: OC San's Specific Obligations.

- A. OC San will provide, at OC San's expense, new frames and covers for the Utilities to replace the existing frames and covers.
- B. OC San will provide, at OC San's expense, inspection services to assure compliance with the Standards. OC San will promptly notify City if any portion of the Adjustment Work appears not to conform to the Standards, and will work with the City to resolve all discrepancies.
- C. OC San will respond to City's request for an inspection within 48 hours. OC San will be responsible for the City's construction contractor's downtime due to failure to comply with this provision.
- D. OC San's obligation to reimburse City includes the actual total costs for construction of the Adjustment Work (including design, permits, and bonds) plus an Administrative Fee (collectively the "**Reimbursement Amount**"), which shall not exceed a cumulative total of \$689,699, unless otherwise approved by OC San or provided herein. The "**Administrative Fee**" is intended to cover the City's internal costs related to administration of the Adjustment Work and is equal to five percent (5%) of the total costs of the Adjustment Work. Any cost of the Adjustment Work that exceeds \$656,856 shall be OC San's sole responsibility. City agrees to notify OC San at the earliest opportunity if the cost of the Adjustment Work is expected to exceed \$656,856 at any time during the Project. If reimbursement over and above \$689,699 is requested by City, OC San staff will request approval from OC San's General Manager or Board of Directors, as appropriate, to increase the Reimbursement Amount, which approval shall not be unreasonably withheld, conditioned, or delayed.

Section 5: Timing of Reimbursement. For each progress payment, including the final progress payment, made by City to its contractor, City shall submit an invoice to OC San setting forth OC San's share of the payment and the amount of the Administrative Fee. Invoices shall be accompanied by a copy of any documentation processed with the progress payment or other documentation to substantiate the calculation of OC San's portion. OC San shall pay City within thirty (30) days of OC San's receipt of all required invoices and supporting documentation.

Section 6: Counterparts. This Agreement may be executed in any number of counterparts with the same effect as if all parties hereto had signed the same document. All such counterparts shall be construed together and shall constitute one agreement, but in making proof hereof it shall only be necessary to produce one such counterpart.

Section 7: Successors and Assigns. This Agreement shall be binding upon and inure to the benefit of City and OC San and their respective legal representatives, successors and assigns. Notwithstanding anything herein to the contrary, the OC San may not assign its rights and obligations under this Agreement without the prior written consent of City. City may assign its

rights or obligations under this Agreement without the OC San's consent, but with notice to the OC San.

Section 8: Indemnity. Each Party hereby agrees to indemnify, defend, protect and hold harmless the other Party, and its elected and appointed officials, officers, employees, representatives, volunteers, and agents from and against any and all claims (including, without limitation, claims for bodily injury, death or damage to property), demands, workers' compensation benefits, obligations, damages, actions, causes of action, suits, losses, judgments, fines, penalties, liabilities, costs and expenses of any kind or nature, arising from any breach of contract, negligent acts, omissions or breach of law, or willful misconduct of the indemnitor, or its officers, agents, or employees arising out of the performance of, or failure to perform, any provisions of this Agreement. Neither Party assumes liability for the acts or omissions of persons other than each Party's respective officers, agents, or employees. In the event judgment is entered against both Parties because of joint or concurrent negligence of both Parties, or their officers, agents, or employees, an apportionment of liability to pay such judgment shall be made by a court of competent jurisdiction. The respective obligations of the Parties pursuant to this Section shall survive expiration or earlier termination of this Agreement.

Section 9: Alteration of Terms. This Agreement fully expresses all understanding of the City and OC San with respect to the subject matter of this Agreement, and shall constitute the total Agreement between the parties for these purposes. No addition to, or alteration of, the terms of this Agreement, whether written or verbal, shall be valid unless made in writing and formally approved and executed by the Parties.

Section 10: Notices. Any notice, tender, demand, delivery, or other communication pursuant to this Agreement shall be in writing and shall be deemed to be properly given if delivered in person or mailed by first class or certified mail, postage prepaid, or sent by telefacsimile or other telegraphic communication in the manner provided in this Section, to the following persons:

CITY: City of Newport Beach
Attn: City Clerk
100 Civic Center Drive
Newport Beach, CA 92660

OC San: Orange County Sanitation District
Attn: Clerk of the Board
10844 Ellis Avenue,
Fountain Valley, CA 92708

A party may change its address by giving notice in writing to the other party. Thereafter, any communication shall be addressed and transmitted to the new address. If sent by mail, communication shall be effective or deemed to have been given three (3) days after it has been deposited in the United States mail, duly registered or certified, with postage prepaid, and addressed as set forth above. If sent by telefacsimile, communication shall be effective or deemed to have been given twenty-four (24) hours after the time set forth on the transmission report issued by the transmitting facsimile machine, addressed as set forth above. For purposes of calculating these time frames, weekends, federal, state, County or City holidays shall be excluded.

Section 11: Term of Agreement. The Effective Date of this Agreement shall be the latter to occur of the following: (a) execution by the City or (b) execution by OC San. The term of the Agreement shall continue in full force and effect until all obligations of OC San to the City are completed in full accordance with the terms of this Agreement.

Section 12: Severability. If any term, provision, covenant, or condition set forth in this Agreement is held by the final judgment of a court of competent jurisdiction to be invalid, void, or unenforceable, the remaining provisions, covenants, and conditions shall continue in full force and effect to the extent that the basic intent of the Parties as expressed herein can be accomplished. In addition, in such event the Parties shall cooperate in good faith in an effort to amend or modify this Agreement in a manner such that the purpose of the invalidated or voided provision, covenant, and condition can be accomplished to the maximum extent legally permissible; provided, however, that in no event shall either party be required to agree to an amendment or modification of this Agreement that materially adversely impacts its rights or materially increases its obligations or risks as set forth herein.

Section 13: Waiver of Default or Breach. Waiver of any default by either party shall not be considered a waiver of any subsequent default. Waiver of any breach by either party of any provision of this Agreement shall not be considered a waiver of any subsequent breach. Waiver of any default or any breach by either party shall not be considered a modification of the terms of this Agreement.

Section 14: No Third-Party Beneficiaries. Nothing in this Agreement is intended to create any third-party beneficiaries to the Agreement, and no person or entity other than the City and OC San, and the permitted successors and assigns of either of them, shall be authorized to enforce the provisions of this Agreement.

Section 15: Further Assurances. OC San and the City agree to execute, acknowledge and deliver any and all additional papers, documents and other assurances and to perform any and all acts and things reasonably necessary in connection with the performance of the obligations hereunder and to carry out the intent of the Parties.

Section 16: Agreement Negotiated. The text of this Agreement is the product of negotiation among the parties and their counsel and is not to be construed as having been prepared by one party or the other.

Section 17: Governing Law. This Agreement shall be governed by and construed in accordance with the laws of the State of California.

Section 18: Termination. OC San may terminate this Agreement at any time, subject to the provisions of this section, by providing five (5) business days' prior written notice to City. If, at the request or direction of a party other than City, the performance of the Adjustment Work is not accomplished or completed, OC San shall remain obligated for the actual amount of the costs incurred by City for that work to the date of termination.

If Caltrans' improvement work or the Project is canceled or modified so as to eliminate the necessity of the construction of the Adjustment Work, City shall have the right to terminate this Agreement and thereby terminate its obligation to perform the Adjustment Work, by providing five (5) business days' prior written notice to OC San. In such case, OC San will not be obligated for any design or any other costs incurred by City. If OC San elects to perform the Adjustment Work, OC San may, but shall not be obligated to, acquire the design or other work from City by separate agreement.

Section 19: Force Majeure. Neither party will be liable for any delays or other non-performance resulting from circumstances or causes beyond its reasonable control, including without limitation, fire or other casualty, act of God, strike or labor dispute, war or other violence, acts of third parties, or any law, order, or requirement of any governmental agency or authority other than the parties.

[SIGNATURES ON NEXT PAGE]

IN WITNESS WHEREOF, the parties are signing this Agreement as of the Effective Date.

ORANGE COUNTY SANITATION DISTRICT, a California public body

Date: _____

By: _____
Chad P. Wanke
Chairperson of the Board

ATTEST

Date: _____

By: _____
Kelly A. Lore, MMC
Clerk of the Board

**APPROVED AS TO FORM:
ALSTON & BIRD**

Date: _____

By: _____
Gregg J Loubier
Special Counsel

CITY OF NEWPORT BEACH,
a California municipal corporation

Date: _____

By: _____
Grace K. Leung
City Manager

ATTEST

Date: _____

By: _____
Leilani I. Brown
City Clerk

**APPROVED AS TO FORM:
CITY ATTORNEY'S OFFICE**

Date: 12/20/23

By:  _____
Aaron C. Harp
City Attorney

12/20/23 WC

EXHIBIT A

Standard Drawings

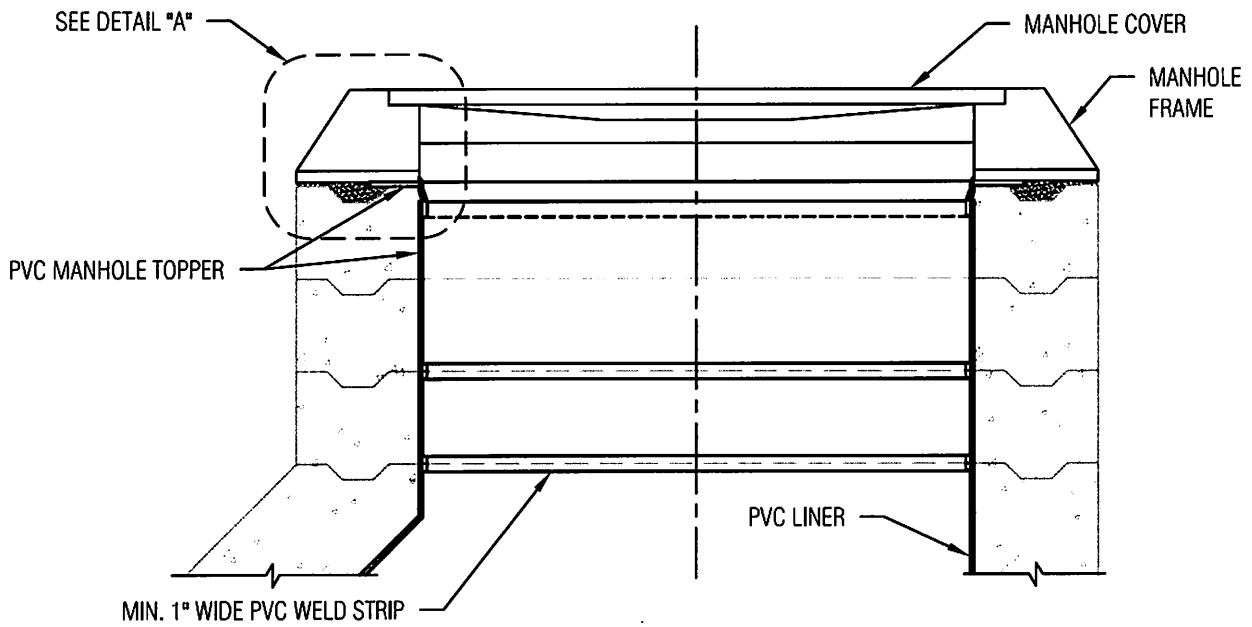
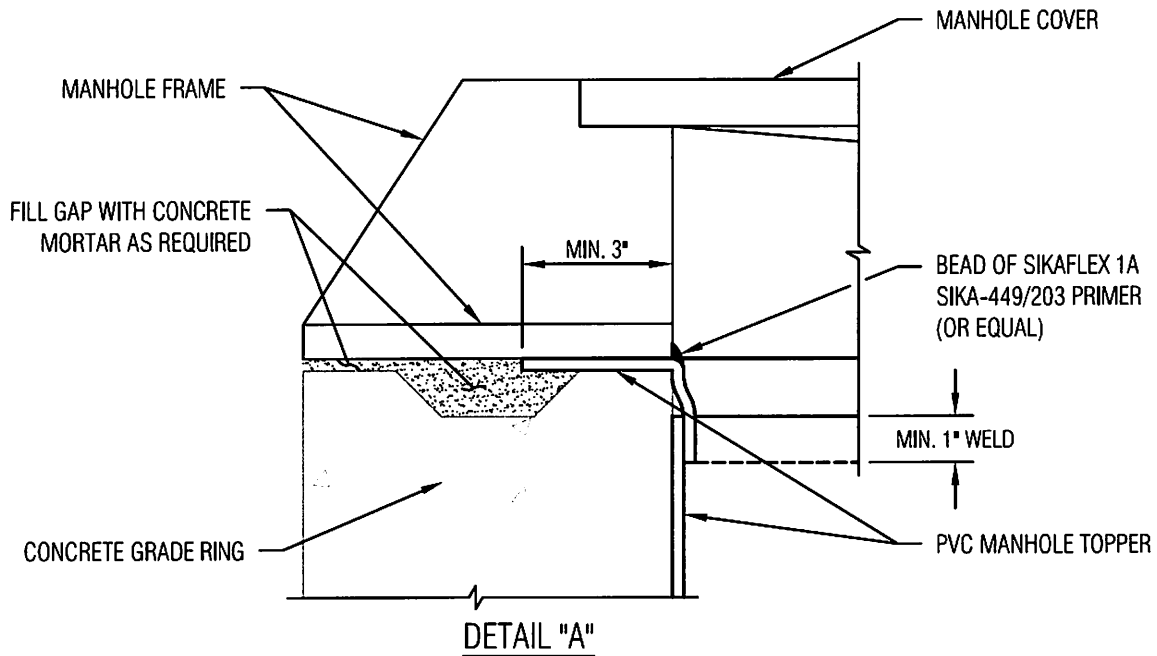

NOTES:

1. MAKE FINAL ADJUSTMENTS AT THE MORTAR JOINT BETWEEN THE FIRST AND SECOND GRADE RINGS. SET FLUSH WITH PAVEMENT TO ONE-EIGHTH INCH HIGH.
2. ADD OR REMOVE GRADE RINGS, REPAIR PVC OR SPRAYED ON LINER, AND SPARK TEST LINER FOR PINHOLES AND "PROBE TEST" FOR WEAK WELDS AS APPROVED BY THE ENGINEER. ADJUST HEIGHT AT MANHOLE RISER SECTIONS IF THE TOTAL HEIGHT OF GRADE RINGS WOULD EXCEED 24 INCHES.
3. BACKFILL FLUSH WITH SURFACE OR BELOW PAVEMENT SURFACE AS REQUIRED GOVERNING AGENCY WITH 3250 PSI (CLASS B) QUICK SETTING CONCRETE FOR COLLAR. EXPOSED CONCRETE SHALL BE BLACK IN COLOR.
4. FILL AREA ABOVE BELOW-GRADE COLLAR WITH AC WEARING SURFACE TO MATCH ADJACENT AC.
5. WHERE ODOR CONDITIONS EXIST OR WHERE DESIGNATED, SEAL MANHOLE RIM AND HOLES WITH DUCT-SEAL MASTIC. RE-SEAL IF EXISTING MANHOLE COVER WAS SEALED.

DWG: J:_CAD Standards\WF\WP_Engineering Standard Drawings\REVISED\050A - PVC LINER INSTALLATION EXISTING MANHOLE ADJUST TO GRADE.dwg
 DATE: Jun 08 2022 9:41am

			ORANGE COUNTY SANITATION DISTRICT ORANGE COUNTY, CALIFORNIA APPROVED BY Millea, Kathleen <small>Digitally signed by Millea, Kathleen Date: 2022.06.23 14:12:35 -0700'</small> DIRECTOR OF ENGINEERING	PVC LINER INSTALLATION EXISTING CONCRETE MANHOLE ADJUST TO GRADE	NO SCALE STANDARD DWG. S-050A
1	EDAC	02/22/2017			
NO.	APPROVED	DATE	DATE		

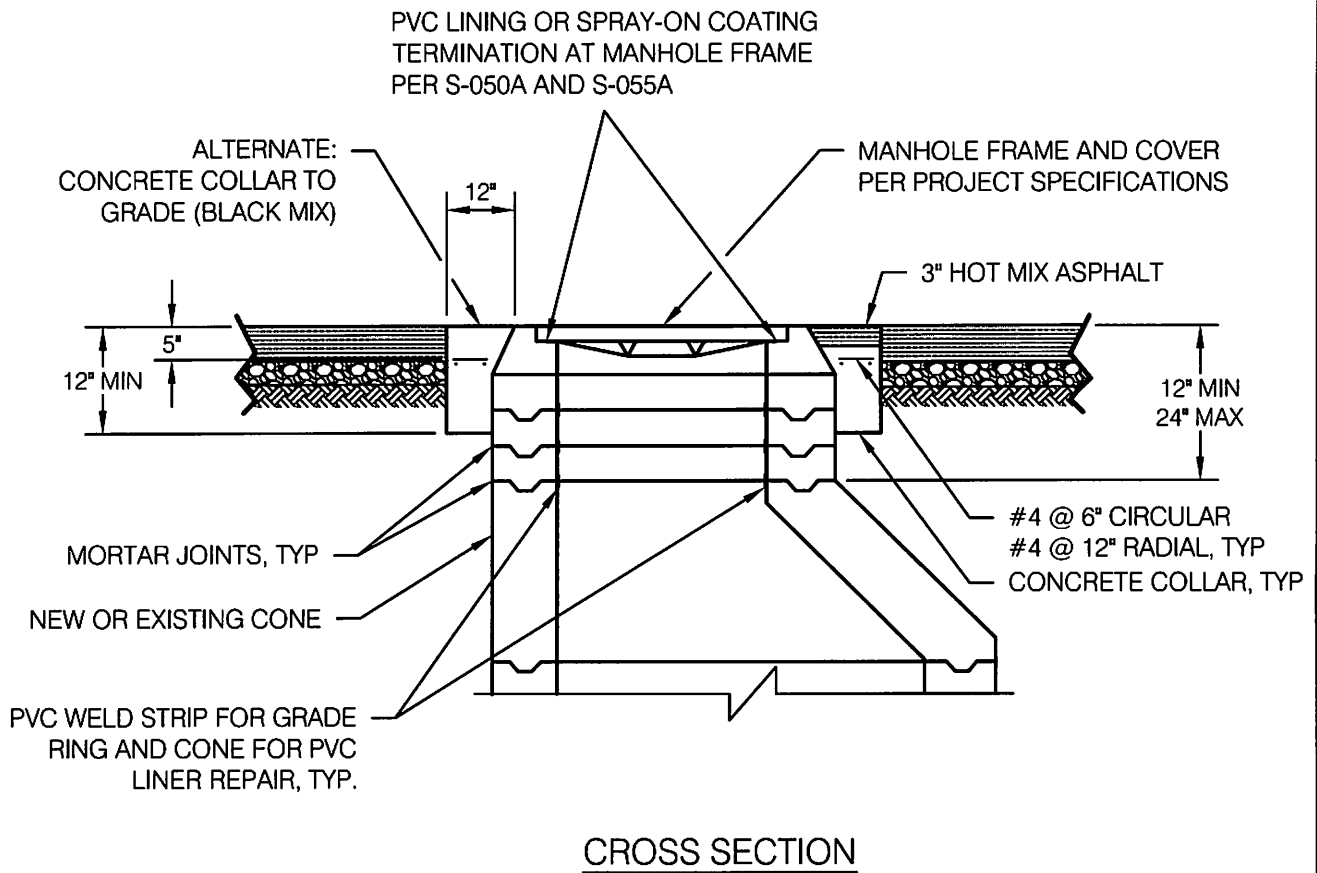

NOTES:

1. NEATLY REMOVE PAVEMENT AND AGGREGATE BASE AS NECESSARY TO MAKE ADJUSTMENT.
2. MAKE FINAL ADJUSTMENTS AT THE MORTAR JOINT BETWEEN THE FIRST AND SECOND GRADE RINGS. SET FLUSH WITH PAVEMENT TO 1/8" HIGH.
3. AT EXISTING MANHOLES, ADD OR REMOVE GRADE RINGS, REPAIR PVC OR SPRAYED LINER, AND SPARK TEST LINER FOR PINHOLES AS APPROVED BY THE ENGINEER. ADJUST HEIGHT AT MANHOLE RISER SECTIONS IF THE TOTAL HEIGHT OF GRADE RINGS WOULD EXCEED 24".
4. BACKFILL FLUSH WITH SURFACE OR BELOW PAVEMENT SURFACE AS REQUIRED BY GOVERNING AGENCY WITH 3250 PSI (CLASS B) QUICK-SETTING CONCRETE TO FORM COLLAR. EXPOSED CONCRETE SHALL BE BLACK IN COLOR.
5. FILL AREA ABOVE BELOW-GRADE COLLAR WITH AC WEARING SURFACE TO MATCH ADJACENT AC.
6. WHERE ODOR CONDITIONS EXIST OR WHERE DESIGNATED, SEAL MANHOLE RIM AND HOLES WITH DUCT-SEAL MASTIC. RE-SEAL IF EXISTING MANHOLE COVER WAS SEALED.

DWG: J:\CAD Standards\WP\WP_Engineering Standard Drawings\REVISED\S-055 - MANHOLE ADJUSTMENT TO GRADE.dwg
 DATE: Jun 08, 2022 9:43am

			ORANGE COUNTY SANITATION DISTRICT ORANGE COUNTY, CALIFORNIA APPROVED BY Millea, Kathleen <small>Digitally signed by Millea, Kathleen Date: 2022.06.23 14:11:46 -0700</small>	MANHOLE ADJUSTMENT TO GRADE	NO SCALE STANDARD DWG. S-055
1	EDAC	02/22/2017	Millea, Kathleen <small>Digitally signed by Millea, Kathleen Date: 2022.06.23 14:11:46 -0700</small>		
NO.	APPROVED	DATE	DIRECTOR OF ENGINEERING <small>DATE</small>		

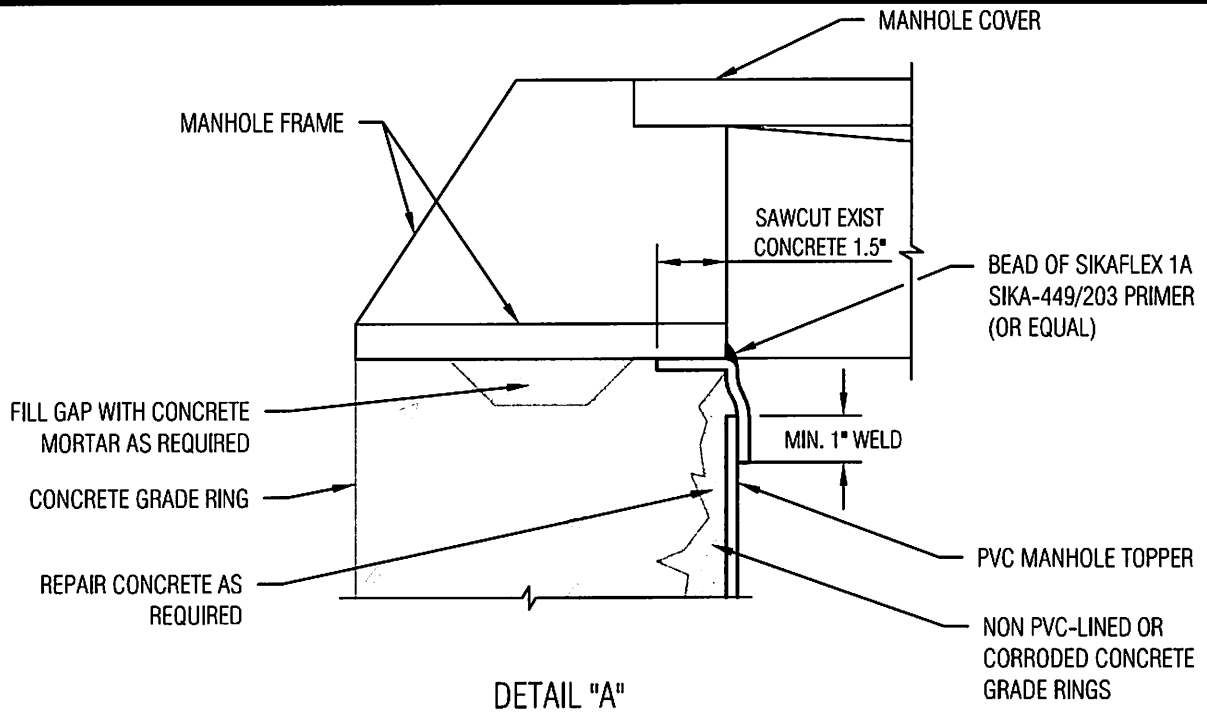

DETAIL "A"

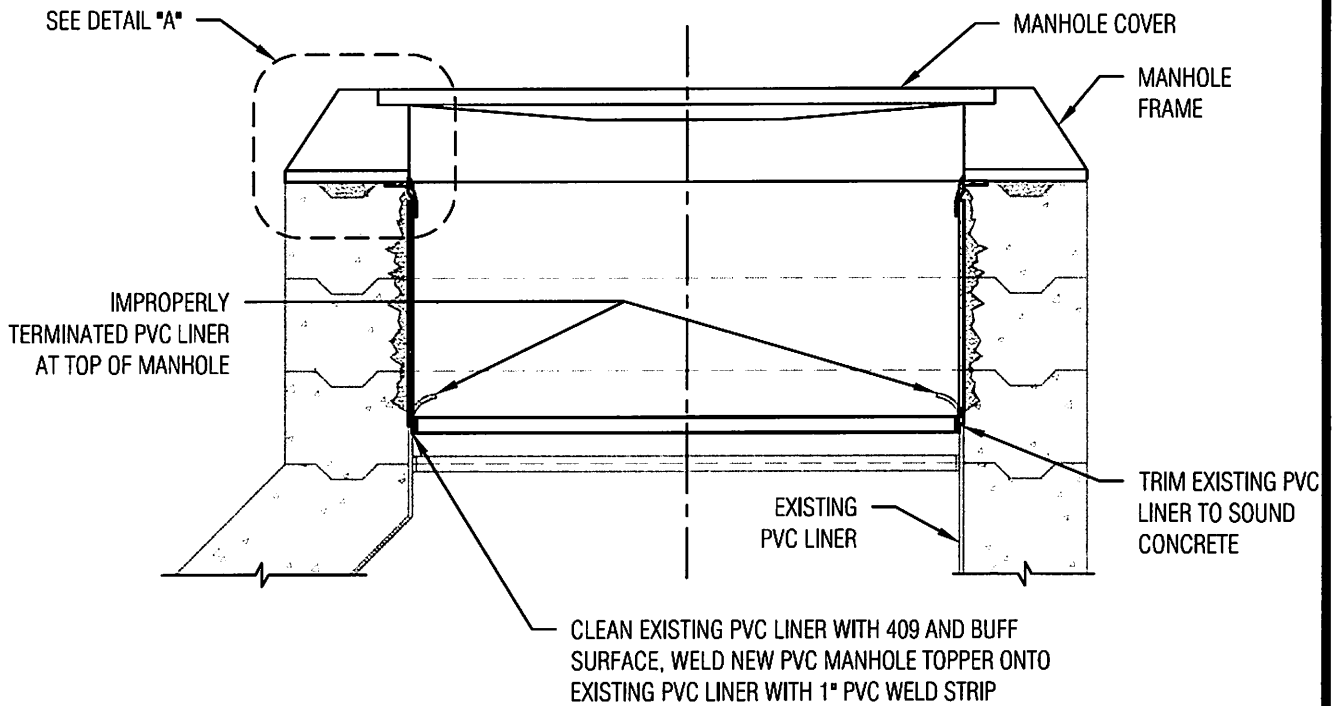

EXISTING MANHOLE PVC LINER DETAIL

NOTES:

1. AT EXISTING MANHOLES, ADD OR REMOVE GRADE RINGS, REPAIR PVC OR SPRAYED ON LINER, AND SPARK TEST LINER FOR PINHOLES AND "PROBE TEST" FOR WEAK WELDS AS APPROVED BY THE ENGINEER. ADJUST HEIGHT AT MANHOLE RISER SECTIONS IF THE TOTAL HEIGHT OF GRADE RINGS WOULD EXCEED 24 INCHES.
2. WHERE ODOR CONDITIONS EXIST OR WHERE DESIGNATED, SEAL MANHOLE RIM AND HOLES WITH DUCT-SEAL MASTIC. RE-SEAL IF EXISTING MANHOLE COVER WAS SEALED.

DWG: J:_CAD Standards\WFWPWP_Engineering Standard Drawings\REVISED-055A - PVC LINER REPAIR EXISTING MANHOLE.dwg
DATE: Jun 08, 2022 9:48am

			ORANGE COUNTY SANITATION DISTRICT ORANGE COUNTY, CALIFORNIA		PVC LINER REPAIR EXISTING CONCRETE MANHOLE		NO SCALE	
			APPROVED BY Millea, Kathleen				STANDARD DWG.	
1	EDAC	02/22/2017	Digitally signed by Millea, Kathleen Date: 2022.06.23 14:13:12 -0700'				S-055A	
NO.	APPROVED	DATE	DIRECTOR OF ENGINEERING		DATE			

10
9
8
7
6
5
4
3
2
1

- KEY NOTES**
- 1 60" MANHOLE RISER, INSTALL PER DETAIL C5025A/C5025B.
 - 2 316 SST WELDOLET NIPPLE.
 - 3 316 SST BLIND FLANGE WITH LIFTING EYES.
 - 4 3" FLANGED SST BALL VALVE, AMERICAN MODEL 4001, OR EQUAL.
 - 5 SEE SECTION A/C5025A AND SECTION A/C5025B FOR CONCRETE ENGAGEMENT DETAIL.

- SHEET NOTES**
1. PRECAST MANHOLE RISERS AND GRADE RISERS SHALL BE PAINTED BY MISO CONTINUOUS TRAFFIC IMPACT LOADING. SEAL ALL JOINTS WITH RAM-NEK SEALANT, OR EQUAL.
 2. PROVIDE BLIND FLANGE WITH 3" WELDED STEEL FLANGED NOZZLE FOR MANUAL AIR RELEASE ASSEMBLY WHERE SHOWN ON DRAWINGS. SEE PLAN AND PROFILE FOR LOCATIONS.
 3. ALL VENT PIPING SHALL BE 316 SST INSIDE.
 4. SEE ACCESS STRUCTURE SCHEDULE ON DWG C5025C FOR MANHOLE STATIONING AND HAND HOLE PLACEMENT.

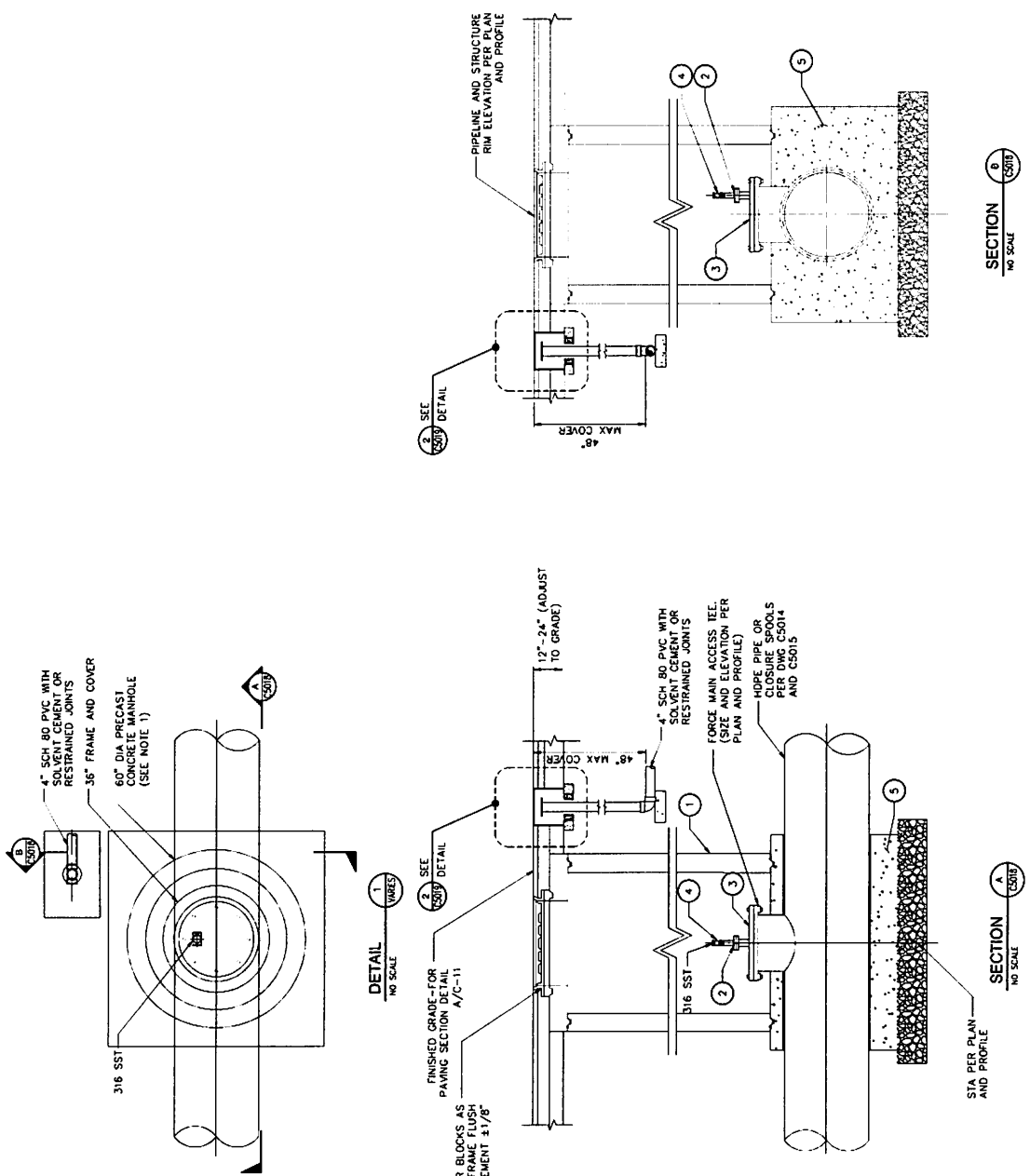

RECORD DRAWING

THESE RECORD DRAWINGS HAVE BEEN PREPARED BASED ON INFORMATION PROVIDED BY OTHERS. THE ENGINEER HAS NOT VERIFIED THE ACCURACY OF THIS INFORMATION AND SHALL NOT BE RESPONSIBLE FOR ANY ERRORS OR OMISSIONS WHICH MAY BE HEREIN AS A RESULT.

PROJECT NO: 5-60
DRAWING NO: C5018
78 OF 109

NEWPORT FORCE MAIN REHABILITATION
MANUAL AIR RELEASE DETAIL



ORANGE COUNTY
SANITATION DISTRICT

Brown and Caldwell
CONSULTANTS

DESIGNED BY: JAM
DRAWN BY: JBC
CHECKED BY: JIB
DATE: 11/15/11

THIS DRAWING WAS PREPARED FOR CONSTRUCTION OF THE NEWPORT FORCE MAIN REHABILITATION PROJECT AND SHALL BE USED ONLY FOR THAT PROJECT. ANY REUSE OF THIS DRAWING FOR OTHER PROJECTS WITHOUT THE WRITTEN CONSENT OF CALTRANS IS PROHIBITED.

MARK	DATE	DESCRIPTION

DESIGNED BY: JAM
DRAWN BY: JBC
CHECKED BY: JIB
DATE: 11/15/11

STA PER PLAN AND PROFILE

SECTION A/C5014
NO SCALE

SECTION B/C5014
NO SCALE

DETAIL A/C5014
NO SCALE

DETAIL B/C5014
NO SCALE

DETAIL C/C5014
NO SCALE

DETAIL D/C5014
NO SCALE

DETAIL E/C5014
NO SCALE

DETAIL F/C5014
NO SCALE

DETAIL G/C5014
NO SCALE

DETAIL H/C5014
NO SCALE

DETAIL I/C5014
NO SCALE

DETAIL J/C5014
NO SCALE

DETAIL K/C5014
NO SCALE

DETAIL L/C5014
NO SCALE

DETAIL M/C5014
NO SCALE

DETAIL N/C5014
NO SCALE

DETAIL O/C5014
NO SCALE

DETAIL P/C5014
NO SCALE

DETAIL Q/C5014
NO SCALE

DETAIL R/C5014
NO SCALE

DETAIL S/C5014
NO SCALE

DETAIL T/C5014
NO SCALE

DETAIL U/C5014
NO SCALE

DETAIL V/C5014
NO SCALE

DETAIL W/C5014
NO SCALE

DETAIL X/C5014
NO SCALE

DETAIL Y/C5014
NO SCALE

DETAIL Z/C5014
NO SCALE

DETAIL AA/C5014
NO SCALE

DETAIL AB/C5014
NO SCALE

DETAIL AC/C5014
NO SCALE

DETAIL AD/C5014
NO SCALE

DETAIL AE/C5014
NO SCALE

DETAIL AF/C5014
NO SCALE

DETAIL AG/C5014
NO SCALE

DETAIL AH/C5014
NO SCALE

DETAIL AI/C5014
NO SCALE

DETAIL AJ/C5014
NO SCALE

DETAIL AK/C5014
NO SCALE

DETAIL AL/C5014
NO SCALE

DETAIL AM/C5014
NO SCALE

DETAIL AN/C5014
NO SCALE

DETAIL AO/C5014
NO SCALE

DETAIL AP/C5014
NO SCALE

DETAIL AQ/C5014
NO SCALE

DETAIL AR/C5014
NO SCALE

DETAIL AS/C5014
NO SCALE

DETAIL AT/C5014
NO SCALE

DETAIL AU/C5014
NO SCALE

DETAIL AV/C5014
NO SCALE

DETAIL AW/C5014
NO SCALE

DETAIL AX/C5014
NO SCALE

DETAIL AY/C5014
NO SCALE

DETAIL AZ/C5014
NO SCALE

DETAIL BA/C5014
NO SCALE

DETAIL BB/C5014
NO SCALE

DETAIL BC/C5014
NO SCALE

DETAIL BD/C5014
NO SCALE

DETAIL BE/C5014
NO SCALE

DETAIL BF/C5014
NO SCALE

DETAIL BG/C5014
NO SCALE

DETAIL BH/C5014
NO SCALE

DETAIL BI/C5014
NO SCALE

DETAIL BJ/C5014
NO SCALE

DETAIL BK/C5014
NO SCALE

DETAIL BL/C5014
NO SCALE

DETAIL BM/C5014
NO SCALE

DETAIL BN/C5014
NO SCALE

DETAIL BO/C5014
NO SCALE

DETAIL BP/C5014
NO SCALE

DETAIL BQ/C5014
NO SCALE

DETAIL BR/C5014
NO SCALE

DETAIL BS/C5014
NO SCALE

DETAIL BT/C5014
NO SCALE

DETAIL BU/C5014
NO SCALE

DETAIL BV/C5014
NO SCALE

DETAIL BW/C5014
NO SCALE

DETAIL BX/C5014
NO SCALE

DETAIL BY/C5014
NO SCALE

DETAIL BZ/C5014
NO SCALE

DETAIL CA/C5014
NO SCALE

DETAIL CB/C5014
NO SCALE

DETAIL CC/C5014
NO SCALE

DETAIL CD/C5014
NO SCALE

DETAIL CE/C5014
NO SCALE

DETAIL CF/C5014
NO SCALE

DETAIL CG/C5014
NO SCALE

DETAIL CH/C5014
NO SCALE

DETAIL CI/C5014
NO SCALE

DETAIL CJ/C5014
NO SCALE

DETAIL CK/C5014
NO SCALE

DETAIL CL/C5014
NO SCALE

DETAIL CM/C5014
NO SCALE

DETAIL CN/C5014
NO SCALE

DETAIL CO/C5014
NO SCALE

DETAIL CP/C5014
NO SCALE

DETAIL CQ/C5014
NO SCALE

DETAIL CR/C5014
NO SCALE

DETAIL CS/C5014
NO SCALE

DETAIL CT/C5014
NO SCALE

DETAIL CU/C5014
NO SCALE

DETAIL CV/C5014
NO SCALE

DETAIL CW/C5014
NO SCALE

DETAIL CX/C5014
NO SCALE

DETAIL CY/C5014
NO SCALE

DETAIL CZ/C5014
NO SCALE

DETAIL DA/C5014
NO SCALE

DETAIL DB/C5014
NO SCALE

DETAIL DC/C5014
NO SCALE

DETAIL DD/C5014
NO SCALE

DETAIL DE/C5014
NO SCALE

DETAIL DF/C5014
NO SCALE

DETAIL DG/C5014
NO SCALE

DETAIL DH/C5014
NO SCALE

DETAIL DI/C5014
NO SCALE

DETAIL DJ/C5014
NO SCALE

DETAIL DK/C5014
NO SCALE

DETAIL DL/C5014
NO SCALE

DETAIL DM/C5014
NO SCALE

DETAIL DN/C5014
NO SCALE

DETAIL DO/C5014
NO SCALE

DETAIL DP/C5014
NO SCALE

DETAIL DQ/C5014
NO SCALE

DETAIL DR/C5014
NO SCALE

DETAIL DS/C5014
NO SCALE

DETAIL DT/C5014
NO SCALE

DETAIL DU/C5014
NO SCALE

DETAIL DV/C5014
NO SCALE

DETAIL DW/C5014
NO SCALE

DETAIL DX/C5014
NO SCALE

DETAIL DY/C5014
NO SCALE

DETAIL DZ/C5014
NO SCALE

DETAIL EA/C5014
NO SCALE

DETAIL EB/C5014
NO SCALE

DETAIL EC/C5014
NO SCALE

DETAIL ED/C5014
NO SCALE

DETAIL EE/C5014
NO SCALE

DETAIL EF/C5014
NO SCALE

DETAIL EG/C5014
NO SCALE

DETAIL EH/C5014
NO SCALE

DETAIL EI/C5014
NO SCALE

DETAIL EJ/C5014
NO SCALE

DETAIL EK/C5014
NO SCALE

DETAIL EL/C5014
NO SCALE

DETAIL EM/C5014
NO SCALE

DETAIL EN/C5014
NO SCALE

DETAIL EO/C5014
NO SCALE

DETAIL EP/C5014
NO SCALE

DETAIL EQ/C5014
NO SCALE

DETAIL ER/C5014
NO SCALE

DETAIL ES/C5014
NO SCALE

DETAIL ET/C5014
NO SCALE

DETAIL EU/C5014
NO SCALE

DETAIL EV/C5014
NO SCALE

DETAIL EW/C5014
NO SCALE

DETAIL EX/C5014
NO SCALE

DETAIL EY/C5014
NO SCALE

DETAIL EZ/C5014
NO SCALE

DETAIL FA/C5014
NO SCALE

DETAIL FB/C5014
NO SCALE

DETAIL FC/C5014
NO SCALE

DETAIL FD/C5014
NO SCALE

DETAIL FE/C5014
NO SCALE

DETAIL FF/C5014
NO SCALE

DETAIL FG/C5014
NO SCALE

DETAIL FH/C5014
NO SCALE

DETAIL FI/C5014
NO SCALE

DETAIL FJ/C5014
NO SCALE

DETAIL FK/C5014
NO SCALE

DETAIL FL/C5014
NO SCALE

DETAIL FM/C5014
NO SCALE

DETAIL FN/C5014
NO SCALE

DETAIL FO/C5014
NO SCALE

DETAIL FP/C5014
NO SCALE

DETAIL FQ/C5014
NO SCALE

DETAIL FR/C5014
NO SCALE

DETAIL FS/C5014
NO SCALE

DETAIL FT/C5014
NO SCALE

DETAIL FU/C5014
NO SCALE

DETAIL FV/C5014
NO SCALE

DETAIL FW/C5014
NO SCALE

DETAIL FX/C5014
NO SCALE

DETAIL FY/C5014
NO SCALE

DETAIL FZ/C5014
NO SCALE

DETAIL GA/C5014
NO SCALE

DETAIL GB/C5014
NO SCALE

DETAIL GC/C5014
NO SCALE

DETAIL GD/C5014
NO SCALE

DETAIL GE/C5014
NO SCALE

DETAIL GF/C5014
NO SCALE

DETAIL GG/C5014
NO SCALE

DETAIL GH/C5014
NO SCALE

DETAIL GI/C5014
NO SCALE

DETAIL GJ/C5014
NO SCALE

DETAIL GK/C5014
NO SCALE

DETAIL GL/C5014
NO SCALE

DETAIL GM/C5014
NO SCALE

DETAIL GN/C5014
NO SCALE

DETAIL GO/C5014
NO SCALE

DETAIL GP/C5014
NO SCALE

DETAIL GQ/C5014
NO SCALE

DETAIL GR/C5014
NO SCALE

DETAIL GS/C5014
NO SCALE

DETAIL GT/C5014
NO SCALE

DETAIL GU/C5014
NO SCALE

DETAIL GV/C5014
NO SCALE

DETAIL GW/C5014
NO SCALE

DETAIL GX/C5014
NO SCALE

DETAIL GY/C5014
NO SCALE

DETAIL GZ/C5014
NO SCALE

DETAIL HA/C5014
NO SCALE

DETAIL HB/C5014
NO SCALE

DETAIL HC/C5014
NO SCALE

DETAIL HD/C5014
NO SCALE

DETAIL HE/C5014
NO SCALE

DETAIL HF/C5014
NO SCALE

DETAIL HG/C5014
NO SCALE

DETAIL HH/C5014
NO SCALE

DETAIL HI/C5014
NO SCALE

DETAIL HJ/C5014
NO SCALE

DETAIL HK/C5014
NO SCALE

DETAIL HL/C5014
NO SCALE

DETAIL HM/C5014
NO SCALE

DETAIL HN/C5014
NO SCALE

DETAIL HO/C5014
NO SCALE

</

1 2 3 4 5 6 7 8 9 10

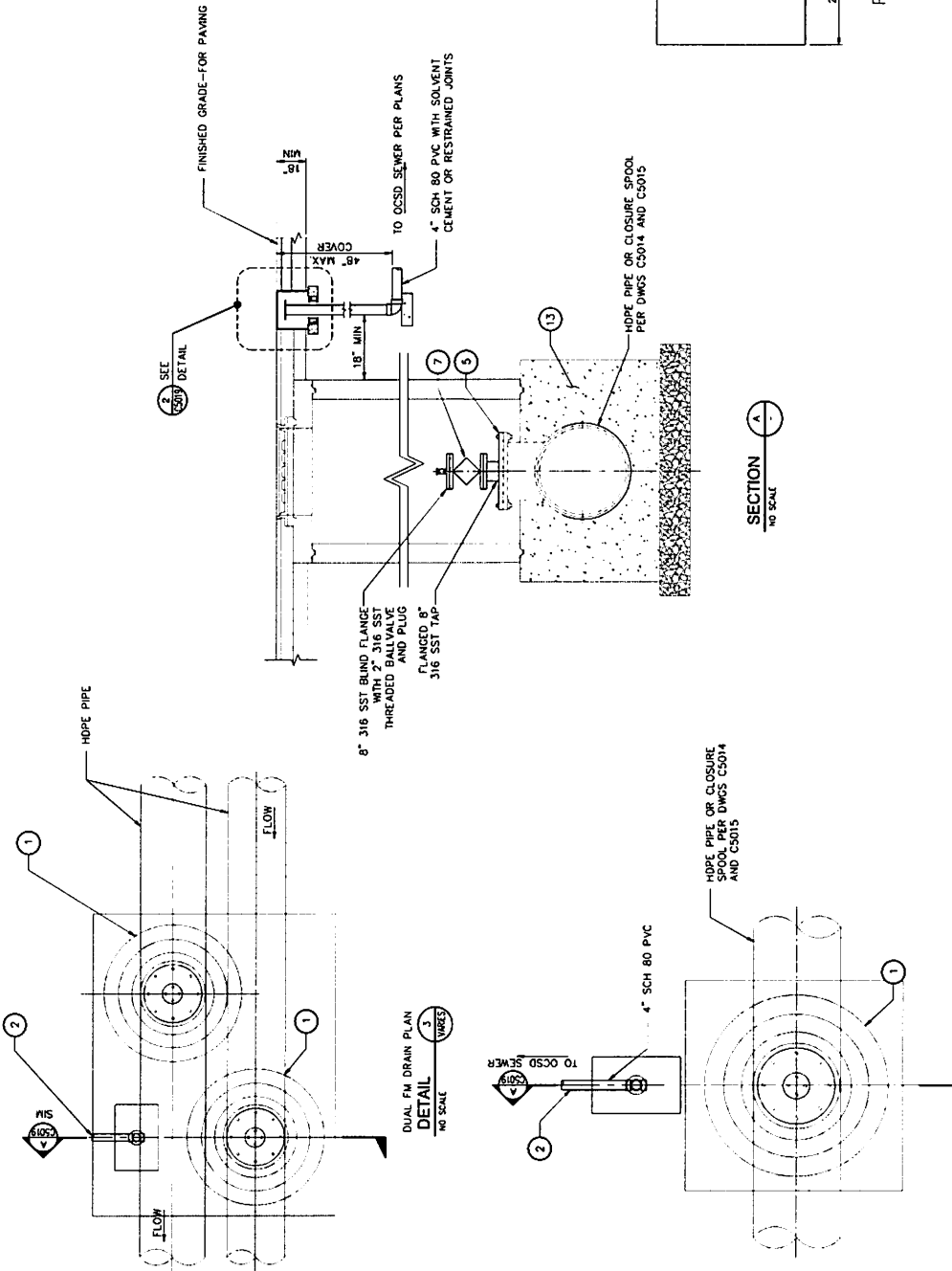

KEY NOTES

- 1 60" DIA MANHOLE PER DETAIL C5025A OR C5025B.
- 2 ROUTE DRAIN PIPING TO OCSD SEWER MANHOLE. PROVIDE 2" MIN. COVER. CONSTRUCT PER DETAIL D/C5029
- 3 SST BLIND FLANGE WITH LIFTING EYES.
- 4 8" FLANGED CAST IRON FUSION BONDED LINED AND COATED FULL-PORT PLUG VALVE
- 5 CALTRANS APPROVED PRECAST TRAFFIC BOX 17" x 17" x 17" COVER, 1/2" THICK, 1/2" RISE, 1/2" BOX OR EQUAL LONG AXIS OF VAULT TO PARALLEL ROADWAY CENTERLINE.
- 6 CALTRANS APPROVED STEEL BOLT DOWN CHECKER COVER, 1/2" THICK, 1/2" RISE, 1/2" BOX, 4" SCH 80 FLANGE AND PVC BLIND FLANGE WITH SST BOLTS, NUTS, AND WASHERS.
- 7 6" x 6" CLASS A CONCRETE FOOTING ALL AROUND VAULT BOTTOM.
- 8 3/4" CRUSHED DRAIN ROCK.
- 9 SEE SECTION A/C5025A AND SECTION A/C5025B FOR CONCRETE ENGAGEMENT DETAIL.

SHEET NOTES

1. PRECAST MANHOLE RISERS AND GRADE RINGS SHALL BE RATED FOR HS20 CONTINUOUS TRAFFIC IMPACT LOADING. ALL JOINTS WITH RAIL-NEK SEALANT, OR EQUAL.
2. SEE ACCESS STRUCTURE SCHEDULE ON DWG C5025C FOR MANHOLE STATIONING AND HAND HOLE PLACEMENT.

RECORD DRAWING

RECORD DRAWING
THESE RECORD DRAWINGS HAVE BEEN PREPARED BASED ON INFORMATION PROVIDED BY OTHERS. THE ENGINEER HAS NOT VERIFIED THE ACCURACY OF THIS INFORMATION AND SHALL NOT BE RESPONSIBLE FOR ANY ERRORS OR OMISSIONS WHICH MAY BE HEREIN AS A RESULT.

PROJECT NO. 5-60
DRAWING NO. C5019
79 OF 109

NEWPORT FORCE MAIN REHABILITATION
ORANGE COUNTY
SANITATION DISTRICT



Brown and Caldwell
INCORPORATED
1000 WEST 10TH AVENUE
SUITE 1000
DENVER, COLORADO 80202
WWW.BROWNANDCOLDWELL.COM

THIS DRAWING WAS PREPARED FOR CONSTRUCTION ON THE BASIS OF THE INFORMATION PROVIDED BY OTHERS. THE ENGINEER HAS NOT VERIFIED THE ACCURACY OF THIS INFORMATION AND SHALL NOT BE RESPONSIBLE FOR ANY ERRORS OR OMISSIONS WHICH MAY BE HEREIN AS A RESULT.

DESIGNED BY: JME
DRAWN BY: JIC
CHECKED BY: JBS
DATE: 11/13/2017
SCALE: AS SHOWN
(IF NOT 7-SCALE ACCORDING TO)

MARK	DESCRIPTION	DATE	APPR.

10
9
8
7
6
5
4
3
2
1

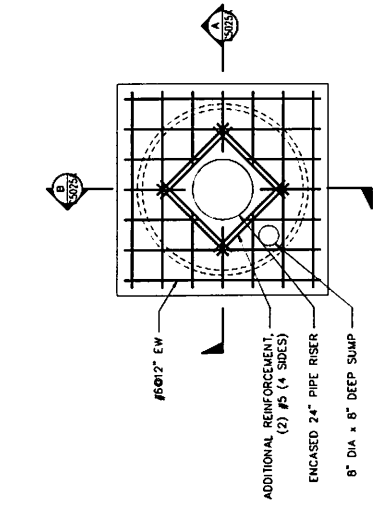
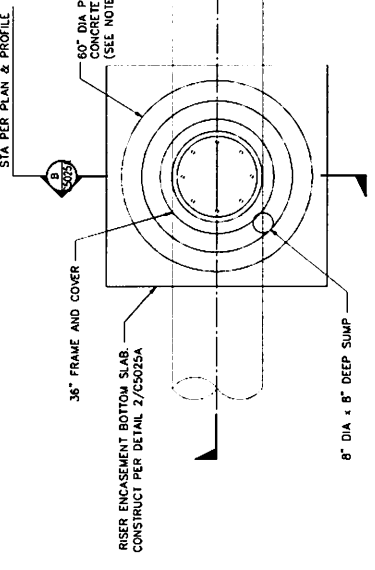

- KEY NOTES**
- 60" MANHOLE RISER.
 - MANHOLE BASE.
 - HDPE WEEP RING OR HYDROPHILIC WATER STOP.
 - 316 SST BLIND FLANGE WITH LIFTING EYES TYP. MODIFY AS SHOWN ON DETAILS C5018 AND C5019 WHERE AIR RELEASE AND DRAIN ASSEMBLIES ARE REQUIRED PER PLAN AND PROFILE AND DWG C5025C.
 - 36" DIA MANHOLE FRAME AND COVER PER CCSD STANDARD DETAIL S-054 ON DWG C5029. PROVIDE BOLT DOWN FRAME.

SINGLE FM ACCESS STRUCTURE DETAIL
NO SCALE

TOP SLAB REINFORCEMENT PLAN DETAIL
NO SCALE

SHEET NOTES

- PRECAST MANHOLE RISERS AND GRADE RINGS SHALL BE SET FOR RISED JOINTS WITH RAM-NEK SEALANT, OR EQUAL.
- SEE ACCESS STRUCTURE SCHEDULE PER DWG C5029C.

SINGLE FM ACCESS STRUCTURE DETAIL
NO SCALE

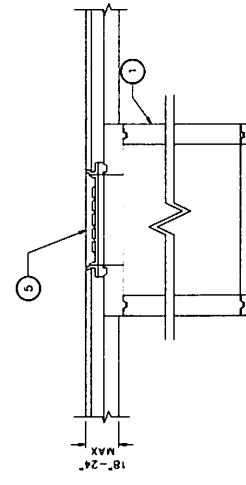
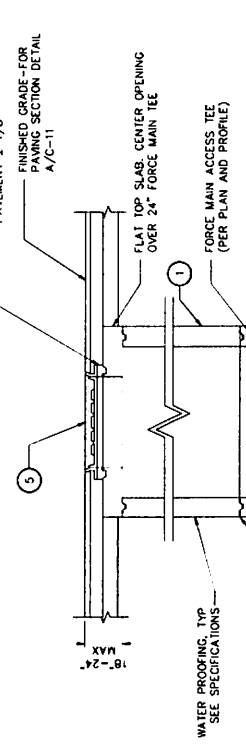

SINGLE FM ACCESS STRUCTURE DETAIL
NO SCALE

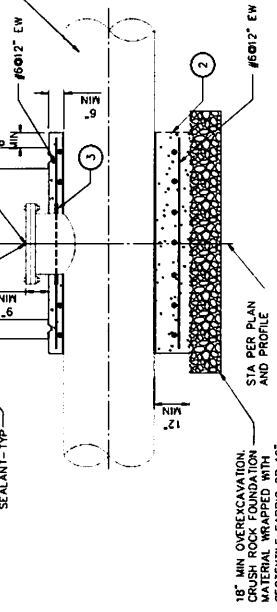

SECTION B
NO SCALE

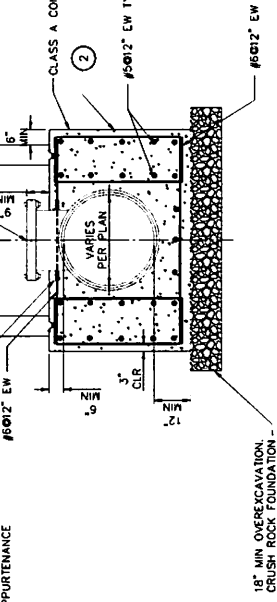

RECORD DRAWING
THESE RECORD DRAWINGS HAVE BEEN PREPARED BASED ON INFORMATION PROVIDED BY OTHERS. THE ENGINEER HAS NOT VERIFIED THE ACCURACY OF THIS INFORMATION AND SHALL NOT BE RESPONSIBLE FOR ANY ERRORS OR OMISSIONS WHICH MAY BE HEREIN AS A RESULT.

PROJECT NO. 5-60
DRAWING NO. C5025A
85 OF 109

NEWPORT FORCE MAIN REHABILITATION
SINGLE FM ACCESS STRUCTURE
DETAIL



Brown and Caldwell
CONSULTANTS
1000 WEST 10TH AVENUE
SUITE 200
DENVER, CO 80202
(303) 733-8800
WWW.BROWNANDCALDWELL.COM

DESIGNED BY: UM
DRAWN BY: BC
CHECKED BY: US
DATE: 11/13/17
SCALE: AS SHOWN

THIS DRAWING HAS BEEN REVIEWED FOR CONSTRUCTION ON THE DATE SHOWN AND IS NOT TO BE USED FOR ANY OTHER PROJECTS WITHOUT THE WRITTEN APPROVAL OF BROWN AND CALDWELL.

MARK	DESCRIPTION	DATE	APPR.



STEERING COMMITTEE

Agenda Report

Administration Building
10844 Ellis Avenue
Fountain Valley, CA 92708
(714) 593-7433

File #: 2024-3433

Agenda Date: 1/17/2024

Agenda Item No: 7.

FROM: Robert Thompson, General Manager
Originator: Lorenzo Tyner, Assistant General Manager

SUBJECT:

SOLICITATION OF GENERAL LEGAL SERVICES

GENERAL MANAGER'S RECOMMENDATION

RECOMMENDATION:

Provide an update on the solicitation, scope of work, and contract structure for the upcoming General Legal Services procurement.

BACKGROUND

In December 2023, the General Legal Services Ad Hoc Committee discussed factors affecting the structure of the solicitation and contract.

RELEVANT STANDARDS

- Ensure the public's money is wisely spent

PRIOR COMMITTEE/BOARD ACTIONS

November 2023 - Board of Directors approved conducting an open competitive solicitation for general legal counsel services; and assigned the General Legal Services Ad Hoc Committee as oversight for the solicitation process.

ADDITIONAL INFORMATION

An overview of the solicitation and contract structure as recommended by the General Legal Services Ad Hoc Committee will be provided.

ATTACHMENT

The following attachment(s) may be viewed on-line at the OC San website (www.ocsan.gov) with the complete agenda package:

- Draft Scope of Work

**EXHIBIT A
SCOPE OF WORK
GENERAL LEGAL SERVICES
SPECIFICATION NO. CS-2024-1440BD**

EXECUTIVE SUMMARY/OVERVIEW

The Orange County Sanitation District (OC San) operates the third largest wastewater agency west of the Mississippi River. Since 1954, we have safely collected, treated, and disposed of and/or reclaimed the wastewater generated by 2.6 million people living and working in central and northwestern Orange County, California.

Each day we treat approximately 180 million gallons of wastewater, enough water to fill Anaheim stadium over two and a quarter times. About 80 percent of the wastewater comes from homes – sinks, toilets, showers, laundry, and dishwashers. The remaining come from businesses – retail stores, restaurants, manufacturers, hotels, offices, and other industries.

OC San is a special district, governed by a 25-member Board of Directors. For the Fiscal Year 2022-23, OC San’s total Operating and Capital Improvement Program budget was \$476.5 million.

We employ a staff of over 600 employees in professional, administrative, technical, and trade occupations, managing the day-to-day activities of OC San, including, but not limited to, in areas of public works, contracts, environmental, air quality, real estate, and utility rates. We have a diverse workforce in various job classifications including plant operators, mechanics, electricians, engineers, scientists, accountants, construction inspectors, among many others. Our facilities include 388 miles of sewer pipes, located throughout the county, and two treatment plants (one in Fountain Valley, CA and the other in Huntington Beach, CA) where wastewater is treated in accordance with strict state and federal standards. A future Headquarters Complex building to house OC San’s administrative support departments is slated for completion in early 2024.

Our employees are on duty protecting public health and the environment by ensuring the sewer system operates efficiently 24 hours a day, seven days a week, and 365 days a year. We take pride in providing quality service to our ratepayers.

1 PURPOSE

OC San is seeking proposals from qualified legal firm(s) (hereinafter referred to as “Consultant(s)”) to provide legal services on an as-needed basis. Proposals are solicited in accordance with the terms, conditions, and instructions set forth in the Request for Proposal (RFP).

OC San intends to receive and evaluate proposals from Consultants (Proposals) and enter into a Professional Services Agreement(s) (Agreement) for the legal services to be provided. OC San expects the Consultants providing legal services to be service-oriented, actively involved in the business of OC San, creative in finding solutions to matters, proactive in assisting OC San’s officials and staff mitigate risk and avoid legal pitfalls, and tenacious in defending against claims and lawsuits.

OC San reserves the right to award an Agreement to a single firm for all the legal services requested or multiple Agreements to various firms for general services and/or specified areas of law listed in section 6, Areas of Law and Requirements, below.

2 BACKGROUND

OC San currently has one firm providing legal services in all areas listed in section 6, Areas of Law and Requirements, below. Over recent years, OC San has conducted an effort to competitively solicit all current legal services to ensure OC San is receiving the best value and service available. OC San currently spends between \$1.3 million to \$1.8 million annually for legal services outlined in this RFP.

In 2023, OC San conducted a solicitation to procure and award contracts for Human Resources legal services. The service covered under those agreements are not included in this solicitation.

The following are some data of interest for Consultants. OC San

- Has 49 active construction contracts valued at over \$750 million
- Annually issues over 5,000 purchase orders
- Has over 100 air quality permits
- Adopted 5-year rate increases in 2023
- Has a 10-year CIP budget of \$3.1 billion

3 DESCRIPTION

Through this RFP, OC San seeks qualified legal firms with local offices to act as OC San's outside counsel to provide legal advice and defense on matters, including, but not limited to, general counsel; special district law; public works construction; environmental law; general contracts; utility rate setting; water law; real estate and related matters; air quality law; and other legal advisory services on an as-needed basis.

OC San may continue to employ attorneys who leave a firm selected under this RFP to complete any matters that are pending at the time the attorney leaves the employment of the firm, and OC San may continue to work with such attorney in new matters. Firms selected under this RFP shall cooperate in this respect.

OC San may also hire attorneys outside this procurement when a legal matter requires specialized knowledge, experience, or capacity that the firms selected through this RFP do not possess. This RFP does not entitle any selected firm to obtain actual assignments from OC San. Whether or not a selected firm is given assignments depends on the nature of the matter, the qualifications of the selected firms, and the needs of OC San.

OC San seeks legal services from qualified legal firm(s) with expertise in the areas of law detailed in section 6, Areas of Law and Requirements, below. The services shall be provided under the direction of OC San's Board of Directors or the General Manager, or designee. Consultant shall be retained and compensated in accordance with the fee schedule attached to the Agreement. OC San reserves the right not to accept all terms of the fee schedule submitted by Consultant(s).

Should a conflict of interest arise on an assignment, OC San may engage an alternative firm for such assignment.

OC San makes no commitment or guarantee as to the services that may be requested or billable hours to be worked by Consultant.

4 QUALIFICATIONS

Consultant and its attorneys must possess all active licenses and registrations necessary to practice law in the State of California. Further, it is required that Consultant has the experience and abilities listed below.

- Consultants or their attorneys shall have at least 10 years' experience providing legal services for special districts, municipalities, or other local public agencies in the areas of law specified below and for which they are submitting a proposal, and the staff availability to meet OC San's needs in a timely manner.
- Substantial knowledge and experience in the interpretation of state, federal, and local laws and codes as they relate to special districts and wastewater agencies
- Substantial experience in working with agencies and public boards with multi-million-dollar annual budgets
- Substantial expertise and experience in all aspects of contract law as it pertains to the Public Contract Code and Government Code
- Substantial knowledge of the Brown Act, Political Reform Act, and Government Code section 1090
- Demonstrated ability to speak clearly, concisely, and effectively in public
- Skillful in relating easily and effectively with all members of the Board of Directors, General Manager, OC San staff, and the public

5 GENERAL REQUIREMENTS

Consultant shall:

- Adhere to the highest standards of fiscal responsibility and accountability
- Provide quality service that meets OC San's needs. This should be achieved through the Consultant's experienced legal team, who shall demonstrate proficiency in the applicable areas of law specified in section 6, Areas of Law and Requirements, below; efficient use of workforce; material resources; and technology to deliver the requested services
- Respond to inquiries from OC San within 24 hours of the initial contact and maintain reasonable availability to respond to requests and events of an emergent nature that expose OC San to serious potential legal liability
- Be promptly available for telephone consultation and to render written opinions on given issues related to OC San business in a timely manner
- Provide written or oral reports in a timely manner to the Board of Directors regarding status of any legal actions in which OC San is or may be involved.

6 AREAS OF LAW AND REQUIREMENTS

6.1 General Counsel

- Provide general legal advice
- Provide advice on
 - wastewater business and administration
 - consulting and training services
 - Board policies and procedures
 - California Public Records Act
- Provide interpretation of and advice on the Public Contract Code and Government Code as it pertains to business matters and public construction
- Provide advice and assistance with Intergovernmental agreements, partnerships, and complex contracts, including drafting, reviewing, negotiating, and related litigation
- Represent OC San in
 - inter-agency projects and other legal matters
 - administrative, litigation and court proceedings
- Maintain knowledge base of issues facing sewer and special districts and be prepared to offer advice and legal opinions in a timely manner
- Prepare, review, consult, and approve contracts
- Review and approve legislative documents for Board of Directors' action items
- Assess liability for Board of Directors and Elected official issues
- Work with other assigned OC San counsel as needed
- Attend work sessions and regular Board meetings (open and closed sessions) and special Board meetings/workshops with the Board of Directors and staff when requested
- Advise on Brown Act and Board agenda items
- Report to and receive assignments from the General Manager or designee
- Monitor or supervise litigation activity handled by other firms
- Review citations for violations of OC San ordinances in accordance with criminal/civil law and procedures; prepare and try infractions, misdemeanors, and ordinance violations as required and requested by the General Manager
- Represent and advise the Board of Directors as the governing body and all OC San officers in all matters of law pertaining to their offices
- Represent and appear in legal proceedings for any current or former OC San Officer and/or employee for which such officer or employee is entitled by law to representation furnished by OC San
- Investigate all claims and complaints by or against OC San and prepare civil cases and act as trial counsel as required and requested by the Board of Directors or General Manager
- Oversee and manage OC San's legal affairs, ensuring that OC San's policies and programs and activities of OC San's employees and agents are carried out in compliance with all applicable laws and that the best interests of OC San are otherwise protected to the fullest extent possible
- Attend, in-person or remotely, regular or special meetings of OC San and its duly appointed committees for which attendance is requested by the General Manager/Board Chair, unless excused by the General Manager/Board Chair
- Attend Board meetings and be prepared to advise the Board of Directors and staff on matters on the agenda as well as parliamentary procedure and substantive issues that may arise

- Attend in-person Executive Management Meetings twice per month, unless excused by the General Manager
- Conduct regular office hours at the OC San designated office. Preferred office hours are half a day four times a month, or as negotiated
- Review agendas and conduct related consultation with OC San staff and members of the Board of Directors regarding the proper placement and/or description of business items on agendas
- Review, analyze, redact, and/or develop written responses to California Public Records Act requests (Gov. Code section 6250 et seq.)

6.2 Public Construction

- Provide interpretation and advice on public works, including drafting, reviewing, negotiating, and litigating contracts in accordance with the Public Contract Code, Government Code, and other applicable codes
- Provide advice and guidance on competitive bid requirements in accordance with the Public Contract Code, Government code, and other applicable codes
- Provide advice on labor compliance and reporting obligations
- Provide advice and direction on public works and construction, including:
 - Liability
 - Construction claims and litigation
 - Bid and contractor compliance
- Provide advice and guidance as required on various construction and construction management delivery methods, such as CM, CM at Risk, CM Agency, Design-Build, Design-Bid-Build, etc.
- Advise OC San's Board of Directors, General Manager, and designated staff on various legal and construction issues
- Demonstrate a track record for preparing documents and legal advice that will limit OC San's exposure to litigation and change orders, and then minimizing the impact of change orders and effectively handling any potential post-construction litigation

6.3 Environmental Law

- California Environmental Quality Act (CEQA)
- National Environmental Policy Act

6.4 Air Quality

- Rule Interpretation
- Permitting
 - Case precedent consultation
 - Rule applicability (i.e., Supercritical Water Oxidation and Sewage Sludge Incineration Rule)
 - Lowest Achievable Emissions Rate/ Best Available Control Technology
 - CEQA, specific to permit issuance
- SCAQMD/CARB/EPA Enforcement: Title V, non-Title V, and Mobile/Portable Sources
 - Notice of Violation Settlement Agreements
 - Supplemental Environmental Projects
 - Variances before SCAQMD Hearing Board
 - Order of Abatement
 - Compliance Risk Analyses

- Legal Guidance Memos
 - Auditing/self-reporting

6.5 **Utility Rate Setting**

- Taxes
- Assessments
- Fees
- Proposition 218
- Other financial advice

6.6 **Real Estate and Related Matters**

- Acquisition/disposal
- Leases
- Eminent domain
- Easements
- Right of Way
- Encroachments
- Permits
- Other related agreements and negotiations

6.7 **General Contracts**

- Risk transfer provisions
- Advice and counsel on contract term negotiation
- Contract form and template updates

7 DELIVERABLES

7.1 **Invoices**

- Consultant shall issue detailed monthly invoices to OC San, which shall include a detailed description of services, date(s) of service, billed hours, hourly rate, attorney's name, and details regarding any additional costs incurred. Consultant shall also include a summary page of the key areas reflecting the overall time and cost.
- Invoices shall be submitted electronically in a format that can be uploaded and sorted.

7.2 **Reports**

- Consultant shall prepare and submit to OC San monthly and as requested reports concerning the outcome of Consultant's performance of the services rendered.
- Consultant shall provide ongoing and as requested written status updates to the General Manager or designee on all litigated matters.
- Reports shall be submitted electronically in a format that can be uploaded and sorted.

7.3 **Meetings**

- Consultant shall attend quarterly meetings with OC San's General Manager or designee to review current status of open tasks.
- Consultant shall attend OC San's Committee and Board meetings as requested and provide updates and/or legal advice during the meetings.



STEERING COMMITTEE

Agenda Report

Administration Building
10844 Ellis Avenue
Fountain Valley, CA 92708
(714) 593-7433

File #: 2023-3333

Agenda Date: 1/17/2024

Agenda Item No: CS-1

FROM: Robert Thompson, General Manager

SUBJECT:

PUBLIC EMPLOYEE PERFORMANCE EVALUATION 54957(B)(1)

RECOMMENDATION: Convene in Closed Session:

Public Employee Performance Evaluation

Number of Employees: 1

- General Counsel

BACKGROUND

During the course of conducting the business set forth on this agenda as a regular meeting of the Board, the Chairperson may convene the Board in closed session to consider matters of pending real estate negotiations, pending or potential litigation, or personnel matters.

Reports relating to (a) purchase and sale of real property; (b) matters of pending or potential litigation; (c) employment actions or negotiations with employee representatives; or which are exempt from public disclosure under the California Public Records Act, may be reviewed by the Board during a permitted closed session and are not available for public inspection. At such time the Board takes final action on any of these subjects, the minutes will reflect all required disclosures of information.

RELEVANT STANDARDS

- Government Code Sections 54956.8, 54956.9, 54957, or 54957.6, as noted

ATTACHMENT

The following attachment(s) may be viewed on-line at the OC San website (www.ocsan.gov) with the complete agenda package:

- Memorandum from General Counsel

WOODRUFF

Woodruff & Smart
A Professional Corporation

MEMORANDUM

TO: Hon. Chair and Members of the Orange County Sanitation District Steering Committee

FROM: Bradley R. Hogin, Esq.
General Counsel

DATE: January 8, 2024

RE: Closed Session Items

The Steering Committee desires to hold a closed session on January 17, 2024 for the purpose of conferring for the evaluation of the District's General Counsel. Said closed session will be held pursuant to authority of California Government Code Section 54957(b)(1).

Respectfully submitted,

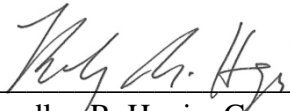
By  _____
Bradley R. Hogin, General Counsel



STEERING COMMITTEE

Agenda Report

Administration Building
10844 Ellis Avenue
Fountain Valley, CA 92708
(714) 593-7433

File #: 2024-3436

Agenda Date: 1/17/2024

Agenda Item No: CS-2

FROM: Robert Thompson, General Manager

SUBJECT:

CONFERENCE WITH LEGAL COUNSEL RE ANTICIPATED LITIGATION - GOVERNMENT CODE SECTION 54956.9(d)(4)

GENERAL MANAGER'S RECOMMENDATION

RECOMMENDATION: Convene in Closed Session:

Number of Potential Cases: 1

Potential initiation of litigation regarding Miller-Holder Easement.

BACKGROUND

During the course of conducting the business set forth on this agenda as a regular meeting of the Board, the Chairperson may convene the Board in closed session to consider matters of pending real estate negotiations, pending or potential litigation, or personnel matters.

Reports relating to (a) purchase and sale of real property; (b) matters of pending or potential litigation; (c) employment actions or negotiations with employee representatives; or which are exempt from public disclosure under the California Public Records Act, may be reviewed by the Board during a permitted closed session and are not available for public inspection. At such time the Board takes final action on any of these subjects, the minutes will reflect all required disclosures of information.

RELEVANT STANDARDS

- Government Code Sections 54956.8, 54956.9, 54957, or 54957.6, as noted

ATTACHMENT

The following attachment(s) may be viewed on-line at the OC San website (www.ocsan.gov) with the complete agenda package:

- Memorandum from General Counsel

WOODRUFF

Woodruff & Smart
A Professional Corporation

MEMORANDUM

TO: Hon. Chair and Members of the Orange County Sanitation District Steering Committee

FROM: Bradley R. Hogin, Esq.
General Counsel

DATE: January 8, 2024

RE: Closed Session Items

The Committee desires to hold a closed session on January 17, 2024 for the purpose of conferring with its legal counsel regarding potential litigation. Based on existing facts and circumstances, the Committee is deciding whether to initiate litigation against another party. The closed session will be held pursuant to the authority of California Government Code Section 54956.9(d)(4).

The facts and circumstances are as follows. OC San owns a 30-foot-wide easement that allows OC San to access the Miller-Holder pipeline. A number of homeowners in Huntington Beach have interfered with OC San's property rights by placing permanent structures on the easement. The offending structures lie adjacent to the Union Pacific rail line between Kim Lane to the north and the East Garden Grove Wintersburg channel to the south.

Respectfully submitted,

By 
Bradley R. Hogin, General Counsel

ORANGE COUNTY SANITATION DISTRICT COMMON ACRONYMS

ACWA	Association of California Water Agencies	LOS	Level Of Service	RFP	Request For Proposal
APWA	American Public Works Association	MGD	Million Gallons Per Day	RWQCB	Regional Water Quality Control Board
AQMD	Air Quality Management District	MOU	Memorandum of Understanding	SARFPA	Santa Ana River Flood Protection Agency
ASCE	American Society of Civil Engineers	NACWA	National Association of Clean Water Agencies	SARI	Santa Ana River Interceptor
BOD	Biochemical Oxygen Demand	NEPA	National Environmental Policy Act	SARWQCB	Santa Ana Regional Water Quality Control Board
CARB	California Air Resources Board	NGOs	Non-Governmental Organizations	SAWPA	Santa Ana Watershed Project Authority
CASA	California Association of Sanitation Agencies	NPDES	National Pollutant Discharge Elimination System	SCADA	Supervisory Control And Data Acquisition
CCTV	Closed Circuit Television	NWRI	National Water Research Institute	SCAP	Southern California Alliance of Publicly Owned Treatment Works
CEQA	California Environmental Quality Act	O & M	Operations & Maintenance	SCAQMD	South Coast Air Quality Management District
CIP	Capital Improvement Program	OCCOG	Orange County Council of Governments	SOCWA	South Orange County Wastewater Authority
CRWQCB	California Regional Water Quality Control Board	OCHCA	Orange County Health Care Agency	SRF	Clean Water State Revolving Fund
CWA	Clean Water Act	OCSD	Orange County Sanitation District	SSMP	Sewer System Management Plan
CWEA	California Water Environment Association	OCWD	Orange County Water District	SSO	Sanitary Sewer Overflow
EIR	Environmental Impact Report	OOBS	Ocean Outfall Booster Station	SWRCB	State Water Resources Control Board
EMT	Executive Management Team	OSHA	Occupational Safety and Health Administration	TDS	Total Dissolved Solids
EPA	US Environmental Protection Agency	PCSA	Professional Consultant/Construction Services Agreement	TMDL	Total Maximum Daily Load
FOG	Fats, Oils, and Grease	PDSA	Professional Design Services Agreement	TSS	Total Suspended Solids
gpd	gallons per day	PFAS	Per- and Polyfluoroalkyl Substances	WDR	Waste Discharge Requirements
GWRS	Groundwater Replenishment System	PFOA	Perfluorooctanoic Acid	WEF	Water Environment Federation
ICS	Incident Command System	PFOS	Perfluorooctanesulfonic Acid	WERF	Water Environment & Reuse Foundation
IERP	Integrated Emergency Response Plan	POTW	Publicly Owned Treatment Works	WIFIA	Water Infrastructure Finance and Innovation Act
JPA	Joint Powers Authority	ppm	parts per million	WIIN	Water Infrastructure Improvements for the Nation Act
LAFCO	Local Agency Formation Commission	PSA	Professional Services Agreement	WRDA	Water Resources Development Act

ORANGE COUNTY SANITATION DISTRICT GLOSSARY OF TERMS

ACTIVATED SLUDGE PROCESS – A secondary biological wastewater treatment process where bacteria reproduce at a high rate with the introduction of excess air or oxygen and consume dissolved nutrients in the wastewater.

BENTHOS – The community of organisms, such as sea stars, worms, and shrimp, which live on, in, or near the seabed, also known as the benthic zone.

BIOCHEMICAL OXYGEN DEMAND (BOD) – The amount of oxygen used when organic matter undergoes decomposition by microorganisms. Testing for BOD is done to assess the amount of organic matter in water.

BIOGAS – A gas that is produced by the action of anaerobic bacteria on organic waste matter in a digester tank that can be used as a fuel.

BIOSOLIDS – Biosolids are nutrient rich organic and highly treated solid materials produced by the wastewater treatment process. This high-quality product can be recycled as a soil amendment on farmland or further processed as an earth-like product for commercial and home gardens to improve and maintain fertile soil and stimulate plant growth.

CAPITAL IMPROVEMENT PROGRAM (CIP) – Projects for repair, rehabilitation, and replacement of assets. Also includes treatment improvements, additional capacity, and projects for the support facilities.

COLIFORM BACTERIA – A group of bacteria found in the intestines of humans and other animals, but also occasionally found elsewhere, used as indicators of sewage pollution. E. coli are the most common bacteria in wastewater.

COLLECTIONS SYSTEM – In wastewater, it is the system of typically underground pipes that receive and convey sanitary wastewater or storm water.

CERTIFICATE OF PARTICIPATION (COP) – A type of financing where an investor purchases a share of the lease revenues of a program rather than the bond being secured by those revenues.

CONTAMINANTS OF POTENTIAL CONCERN (CPC) – Pharmaceuticals, hormones, and other organic wastewater contaminants.

DILUTION TO THRESHOLD (D/T) – The dilution at which the majority of people detect the odor becomes the D/T for that air sample.

GREENHOUSE GASES (GHG) – In the order of relative abundance water vapor, carbon dioxide, methane, nitrous oxide, and ozone gases that are considered the cause of global warming (“greenhouse effect”).

GROUNDWATER REPLENISHMENT SYSTEM (GWRS) – A joint water reclamation project that proactively responds to Southern California’s current and future water needs. This joint project between the Orange County Water District and OCSD provides 70 million gallons per day of drinking quality water to replenish the local groundwater supply.

LEVEL OF SERVICE (LOS) – Goals to support environmental and public expectations for performance.

N-NITROSODIMETHYLAMINE (NDMA) – A N-nitrosamine suspected cancer-causing agent. It has been found in the GWRS process and is eliminated using hydrogen peroxide with extra ultra-violet treatment.

NATIONAL BIOSOLIDS PARTNERSHIP (NBP) – An alliance of the NACWA and WEF, with advisory support from the EPA. NBP is committed to developing and advancing environmentally sound and sustainable biosolids management practices that go beyond regulatory compliance and promote public participation to enhance the credibility of local agency biosolids programs and improved communications that lead to public acceptance.

PER- AND POLYFLUOROALKYL SUBSTANCES (PFAS) – A large group (over 6,000) of human-made compounds that are resistant to heat, water, and oil and used for a variety of applications including firefighting foam, stain and water-resistant clothing, cosmetics, and food packaging. Two PFAS compounds, perfluorooctanesulfonic acid (PFOS) and perfluorooctanoic acid (PFOA) have been the focus of increasing regulatory scrutiny in drinking water and may result in adverse health effects including developmental effects to fetuses during pregnancy, cancer, liver damage, immunosuppression, thyroid effects, and other effects.

PERFLUOROCTANOIC ACID (PFOA) – An ingredient for several industrial applications including carpeting, upholstery, apparel, floor wax, textiles, sealants, food packaging, and cookware (Teflon).

PERFLUOROCTANESULFONIC ACID (PFOS) – A key ingredient in Scotchgard, a fabric protector made by 3M, and used in numerous stain repellents.

PLUME – A visible or measurable concentration of discharge from a stationary source or fixed facility.

PUBLICLY OWNED TREATMENT WORKS (POTW) – A municipal wastewater treatment plant.

SANTA ANA RIVER INTERCEPTOR (SARI) LINE – A regional brine line designed to convey 30 million gallons per day of non-reclaimable wastewater from the upper Santa Ana River basin to the ocean for disposal, after treatment.

SANITARY SEWER – Separate sewer systems specifically for the carrying of domestic and industrial wastewater.

SOUTH COAST AIR QUALITY MANAGEMENT DISTRICT (SCAQMD) – Regional regulatory agency that develops plans and regulations designed to achieve public health standards by reducing emissions from business and industry.

SECONDARY TREATMENT – Biological wastewater treatment, particularly the activated sludge process, where bacteria and other microorganisms consume dissolved nutrients in wastewater.

SLUDGE – Untreated solid material created by the treatment of wastewater.

TOTAL SUSPENDED SOLIDS (TSS) – The amount of solids floating and in suspension in wastewater.

ORANGE COUNTY SANITATION DISTRICT GLOSSARY OF TERMS

TRICKLING FILTER – A biological secondary treatment process in which bacteria and other microorganisms, growing as slime on the surface of rocks or plastic media, consume nutrients in wastewater as it trickles over them.

URBAN RUNOFF – Water from city streets and domestic properties that carry pollutants into the storm drains, rivers, lakes, and oceans.

WASTEWATER – Any water that enters the sanitary sewer.

WATERSHED – A land area from which water drains to a particular water body. OCSD's service area is in the Santa Ana River Watershed.