

**GENERAL SERVICES CONTRACT  
MANHOLE REHABILITATION SERVICES  
Specification No. S-2023-1391BD**

This GENERAL SERVICES CONTRACT (hereinafter referred to as "Contract"), is made and entered into as of the date fully executed below, by and between Orange County Sanitation District (hereinafter referred to as "OC San") and \_\_\_\_\_ (hereinafter referred to as "Contractor"), and collectively referred to herein as the "Parties."

**RECITALS**

WHEREAS, OC San desires to retain the services of Contractor for Manhole Rehabilitation Services ("Services") as described in Exhibit "A" attached hereto and incorporated herein by this reference; and

WHEREAS, Contractor is qualified to perform the Services by virtue of experience, training, education, and expertise; and

WHEREAS, OC San desires to engage Contractor to provide the Services; and

WHEREAS, OC San selected Contractor to provide the Services in accordance with Ordinance No. OC SAN-56; and

WHEREAS, on \_\_\_\_\_, OC San's Board of Directors, by minute order, authorized execution of this Contract.

NOW, THEREFORE, in consideration of the above recitals and the mutual promises and benefits specified below, the Parties agree as follows:

**1. General.**

1.1 This Contract and all exhibits hereto are made by OC San and the Contractor.

1.2 The following exhibits, in order of precedence, are incorporated by reference and made part of this Contract.

Exhibit "A" – Scope of Work  
Exhibit "B" – Bid  
Exhibit "C" – Determined Insurance Requirement Form  
Exhibit "D" – Contractor Safety Standards  
Exhibit "E" – Human Resources Policies  
Exhibit "F" – Not Used  
Exhibit "G" – Not Used

1.3 In the event of any conflict or inconsistency between the provisions of this Contract and any of the provisions of the exhibits hereto, the provisions in the Contract shall control and thereafter the provisions in the document highest in precedence shall be controlling.

1.4 Except as expressly provided otherwise, OC San accepts no liability for any expenses, losses, or actions incurred or undertaken by Contractor as a result of work performed in anticipation of acquisition of the Services by OC San.

- 1.5 Work Hours: Shall be as specified in Exhibit "A."
- 1.6 Days: Shall mean calendar days, unless otherwise noted.
- 1.7 OC San holidays (non-working days) are as follows: New Year's Day, Martin Luther King, Jr. Day, Presidents' Day, Memorial Day, Independence Day, Labor Day, Veterans Day, Thanksgiving Day, Day after Thanksgiving, Christmas Eve, and Christmas Day.
- 1.8 Work: Shall mean all work, labor, and materials necessary to provide the Services.
- 1.9 The provisions of this Contract may be amended or waived only by an amendment executed by authorized representatives of both Parties.
- 1.10 The various headings in this Contract are inserted for convenience only and shall not affect the meaning or interpretation of this Contract or any paragraph or provision hereof.

**2. Scope of Work.**

- 2.1 Contractor shall perform the Services identified in Exhibit "A" in accordance with generally accepted industry and professional standards.
- 2.2 Modifications to Scope of Work. OC San shall have the right to modify the Scope of Work at any time. All modifications must be made by an amendment signed by both Parties.
- 2.3 Familiarity with Work. By executing this Contract, Contractor warrants that: (a) it has investigated the work to be performed; and (b) it understands the facilities, difficulties, and restrictions of the work under this Contract. Should Contractor discover any latent or unknown condition materially differing from those inherent in the work or as represented by OC San, it shall immediately inform OC San of this and shall not proceed, except at Contractor's risk, until written instructions are received from OC San.
- 2.4 Performance. Time is of the essence in the performance of the provisions hereof.

**3. Contract Term.**

- 3.1 The term of this Contract shall be for one (1) year commencing on the effective date of the Notice to Proceed.
- 3.2 Renewals. At its sole discretion, OC San may exercise the option to renew this Contract for up to four (4) one-year periods. This Contract may be renewed by an OC San Purchase Order. OC San shall have no obligation to renew the Contract nor to give a reason if it elects not to renew it.
- 3.3 Extensions. The term of this Contract may be extended only by an amendment signed by both Parties.

**4. Payments and Invoicing.**

- 4.1 OC San shall pay itemized invoices for work completed in accordance with Exhibit "A", and in accordance with the unit price(s) listed in Exhibit "B" thirty (30) days from receipt of the invoice and after approval by OC San's Project Manager or designee. OC San shall be the determining party, in its sole discretion, as to whether the Services have been satisfactorily completed.

- 4.2 Price adjustments for optional renewal periods may be based upon mutually acceptable price indices.
- 4.3 Contractor shall submit its invoices to OC San Accounts Payable by electronic mail to [APStaff@OCSan.gov](mailto:APStaff@OCSan.gov). In the subject line include "INVOICE" and the Purchase Order Number.

**5. California Department of Industrial Relations Registration and Record of Wages.**

- 5.1 To the extent Contractor's employees and/or its subcontractors perform work related to this Contract for which Prevailing Wage Determinations have been issued by the California Department of Industrial Relations (DIR) as more specifically defined under Labor Code section 1720 et seq., prevailing wages are required to be paid for applicable work under this Contract. It is Contractor's responsibility to interpret and implement any prevailing wage requirements and Contractor agrees to pay any penalty or civil damages resulting from a violation of the prevailing wage laws.
- 5.2 Contractor and its subcontractors shall comply with the registration requirements of Labor Code section 1725.5. Pursuant to Labor Code section 1771.4(a)(1), the work is subject to compliance monitoring and enforcement by the California Department of Industrial Relations (DIR).
- 5.3 Pursuant to Labor Code section 1773.2, a copy of the prevailing rate of per diem wages is available upon request at OC San's principal office. The prevailing rate of per diem wages may also be found at the DIR website for prevailing wage determinations at <http://www.dir.ca.gov/DLSR/PWD>.
- 5.4 Contractor and its subcontractors shall comply with the job site notices posting requirements established by the Labor Commissioner per Title 8, California Code of Regulations section 16461(e). Pursuant to Labor Code sections 1773.2 and 1771.4(a)(2), Contractor shall post a copy of the prevailing rate of per diem wages at the job site.
- 5.5 Contractor and its subcontractors shall maintain accurate payroll records and shall comply with all the provisions of Labor Code section 1776. Contractor and its subcontractors shall submit payroll records to the Labor Commissioner pursuant to Labor Code section 1771.4(a)(3). Pursuant to Labor Code section 1776, the Contractor and its subcontractors shall furnish a copy of all certified payroll records to OC San and/or the general public upon request, provided the public request is made through OC San, the Division of Apprenticeship Standards, or the Division of Labor Standards Enforcement of the Department of Industrial Relations. Pursuant to Labor Code section 1776(h), penalties for non-compliance with a request for payroll records may be deducted from progress payments.
  - 5.5.1 As a condition to receiving payments, Contractor agrees to present to OC San, along with any request for payment, all applicable and necessary certified payrolls and other required documents for the period covering such payment request. Pursuant to Title 8, California Code of Regulations section 16463, OC San shall withhold any portion of a payment, up to and including the entire payment amount, until certified payroll forms and any other required documents are properly submitted. In the event certified payroll forms do not comply with the

requirements of Labor Code section 1776, OC San may continue to withhold sufficient funds to cover estimated wages and penalties under the Contract.

5.6 The Contractor and its subcontractors shall comply with Labor Code section 1774 and section 1775. Pursuant to Labor Code section 1775, the Contractor and any of its subcontractors shall forfeit to OC San a penalty of not more than two hundred dollars (\$200) for each calendar day, or portion thereof, for each worker paid less than the prevailing rates as determined by the DIR for the work or craft in which the worker is employed for any work.

5.6.1 In addition to the penalty and pursuant to Labor Code section 1775, the difference between the prevailing wage rates and the amount paid to each worker for each calendar day or portion thereof for which each worker was paid less than the prevailing wage rate shall be paid to each worker by the Contractor or its subcontractor.

5.7 Contractor and its subcontractors shall comply with Labor Code sections 1810 through 1815. Contractor and its subcontractors shall restrict working hours to eight (8) hours per day and forty (40) hours per week, except that work performed in excess of those limits shall be permitted upon compensation for all excess hours worked at not less than one and one-half (1.5) times the basic rate of pay, as provided in Labor Code section 1815. The Contractor shall forfeit, as a penalty to OC San, twenty-five dollars (\$25) per worker per calendar day during which such worker is required or permitted to work more than eight (8) hours in any one calendar day and forty (40) hours in any one calendar week in violation of Labor Code sections 1810 through 1815.

5.8 Contractor and its subcontractors shall comply with Labor Code sections 1777.5, 1777.6, and 1777.7 concerning the employment of apprentices by Contractor or any subcontractor.

5.9 Contractor shall include, at a minimum, a copy of the following provisions in any contract it enters into with any subcontractor: Labor Code sections 1771, 1771.1, 1775, 1776, 1777.5, 1810, 1813, 1815, 1860, and 1861.

5.10 Pursuant to Labor Code sections 1860 and 3700, the Contractor and its subcontractors will be required to secure the payment of compensation to employees. Pursuant to Labor Code section 1861, Contractor, by accepting this contract, certifies that:

“I am aware of the provisions of section 3700 of the Labor Code which require every employer to be insured against liability for workers’ compensation or to undertake self-insurance in accordance with the provisions of that code, and I will comply with such provisions before commencing the performance of the work of this contract.”

Contractor shall ensure that all its contracts with its subcontractors provide the provision above.

**6. Damage to OC San’s Property.** Any of OC San’s property damaged by Contractor, any subcontractor, or by the personnel of either will be subject to repair or replacement by Contractor at no cost to OC San.

7. **Freight (F.O.B. Destination).** Contractor assumes full responsibility for all transportation, transportation scheduling, packing, handling, insurance, and other services associated with delivery of all products deemed necessary under this Contract.
8. **Audit Rights.** Contractor agrees that, during the term of this Contract and for a period of three (3) years after its expiration or termination, OC San shall have access to and the right to examine any directly pertinent books, documents, and records of Contractor relating to the invoices submitted by Contractor pursuant to this Contract.
9. **Contractor Safety Standards and Human Resources Policies.** OC San requires Contractor and its subcontractor(s) to follow and ensure their employees follow all Federal, State, and local regulations as well as the Contractor Safety Standards while working at OC San locations. If, during the course of the Contract, it is discovered that the Contractor Safety Standards do not comply with Federal, State, or local regulations, the Contractor is required to follow the most stringent regulatory requirement at no additional cost to OC San. Contractor, its subcontractors, and all of their employees shall adhere to the safety requirements in Exhibit "A," all applicable Contractor Safety Standards in Exhibit "D," and the Human Resources Policies in Exhibit "E."
10. **Insurance.** Contractor and all its subcontractors shall purchase and maintain, throughout the term of this Contract and any periods of warranty or extensions, insurance in amounts equal to the requirements set forth in the signed Exhibit "C" – Determined Insurance Requirement Form. Contractor shall not commence work under this Contract until all required insurance is obtained in a form acceptable to OC San, nor shall Contractor allow any subcontractor to commence service pursuant to a subcontract until all insurance required of the subcontractor has been obtained. Failure to obtain and maintain the required insurance coverage shall result in termination of this Contract.
11. **Bonds.** Not Used.
12. **Indemnification and Hold Harmless Provision.** Contractor shall assume all responsibility for damages to property and/or injuries to persons, including accidental death, which may arise out of or may be caused by Contractor's Services under this Contract, or by its subcontractor(s), or by anyone directly or indirectly employed by Contractor, and whether such damage or injury shall accrue or be discovered before or after the termination of the Contract. Except as to the sole active negligence of or willful misconduct of OC San, Contractor shall indemnify, protect, defend, and hold harmless OC San, its elected and appointed officials, officers, agents, and employees from and against any and all claims, liabilities, damages, or expenses of any nature, including attorneys' fees: (a) for injury to or death of any person, or damage to property, or interference with the use of property arising out of or in connection with Contractor's performance under the Contract, and/or (b) on account of use of any copyrighted or uncopyrighted material, composition, or process; or any patented or unpatented invention, article, or appliance furnished or used under the Contract, and/or (c) on account of any goods and services provided under this Contract. This indemnification provision shall apply to any acts or omissions, willful misconduct, or negligent misconduct, whether active or passive, on the part of Contractor or anyone employed by or working under Contractor. To the maximum extent permitted by law, Contractor's duty to defend shall apply whether or not such claims, allegations, lawsuits, or proceedings have merit or are meritless; or which involve claims or allegations that any of the parties to be defended were actively, passively, or concurrently negligent; or which otherwise assert that the parties to be defended are responsible, in whole

or in part, for any loss, damage, or injury. Contractor agrees to provide this defense immediately upon written notice from OC San, and with well qualified, adequately insured, and experienced legal counsel acceptable to OC San. This section shall survive the expiration or early termination of the Contract.

13. **Independent Contractor.** The relationship between the Parties hereto is that of an independent contractor and nothing herein shall be deemed to make Contractor an OC San employee. During the performance of this Contract, Contractor and its officers, employees, and agents shall act in an independent capacity and shall not act as OC San's officers, employees, or agents. Contractor and its officers, employees, and agents shall obtain no rights to any benefits which accrue to OC San's employees.
14. **Subcontracting and Assignment.** Contractor shall not delegate any duties nor assign any rights under this Contract without the prior written consent of OC San. Any such attempted delegation or assignment shall be void.
15. **Disclosure.** Contractor agrees not to disclose, to any third party, data or information generated from this Contract without the prior written consent from OC San.
16. **Non-Liability of OC San Officers and Employees.** No officer or employee of OC San shall be personally liable to Contractor, or any successor-in-interest, in the event of any default or breach by OC San, or for any amount which may become due to Contractor or to its successor, or for breach of any obligation under the terms of this Contract.
17. **Third-Party Rights.** Nothing in this Contract shall be construed to give any rights or benefits to anyone other than OC San and Contractor.
18. **Applicable Laws and Regulations.** Contractor shall comply with all applicable Federal, State, and local laws, rules, and regulations. Contractor also agrees to indemnify and hold OC San harmless from any and all damages and liabilities assessed against OC San as a result of Contractor's noncompliance therewith. Any provision required by law to be included herein shall be deemed included as a part of this Contract whether or not specifically included or referenced.
19. **Licenses, Permits, Ordinances, and Regulations.** Contractor represents and warrants to OC San that it has obtained all licenses, permits, qualifications, and approvals of whatever nature that are legally required to provide the Services. Any and all fees required by Federal, State, County, City, and/or municipal laws, codes, and/or tariffs that pertain to the work performed under this Contract will be paid by Contractor.
20. **Regulatory Requirements.** Contractor shall perform all work under this Contract in strict conformance with applicable Federal, State, and local regulatory requirements including, but not limited to, 40 CFR 122, 123, 124, 257, 258, 260, 261, and 503, Title 22, 23, and Water Codes Division 2.
21. **Environmental Compliance.** Contractor shall, at its own cost and expense, comply with all Federal, State, and local environmental laws, regulations, and policies which apply to the Contractor, its subcontractors, and the Services, including, but not limited to, all applicable Federal, State, and local air pollution control laws and regulations.

22. **South Coast Air Quality Management District's Requirements.** It is Contractor's responsibility to ensure that all equipment furnished and installed be in accordance with the latest rules and regulations of the South Coast Air Quality Management District (SCAQMD). All Contract work practices, which may have associated emissions such as sandblasting, open field spray painting, or demolition of asbestos containing components or structures shall comply with the appropriate rules and regulations of SCAQMD.
23. **Warranties.** In addition to the warranties stated in Exhibit "A," the following shall apply:  
23.1 Manufacturer's standard warranty shall apply. All manufacturer warranties shall commence on the date of acceptance of the work as complete by the OC San Project Manager or designee.
24. **Dispute Resolution.**  
24.1 In the event of a dispute as to the construction or interpretation of this Contract, or any rights or obligations hereunder, the Parties shall first attempt, in good faith, to resolve the dispute by mediation. The Parties shall mutually select a mediator to facilitate the resolution of the dispute. If the Parties are unable to agree on a mediator, the mediation shall be conducted in accordance with the Commercial Mediation Rules of the American Arbitration Agreement, through the alternate dispute resolution procedures of Judicial Arbitration through Mediation Services of Orange County ("JAMS"), or any similar organization or entity conducting an alternate dispute resolution process.  
24.2 In the event the Parties are unable to timely resolve the dispute through mediation, the issues in dispute shall be submitted to arbitration pursuant to Code of Civil Procedure, Part 3, Title 9, sections 1280 et seq. For such purpose, an agreed arbitrator shall be selected, or in the absence of agreement, each party shall select an arbitrator, and those two (2) arbitrators shall select a third. Discovery may be conducted in connection with the arbitration proceeding pursuant to Code of Civil Procedure section 1283.05. The arbitrator, or three (3) arbitrators acting as a board, shall take such evidence and make such investigation as deemed appropriate and shall render a written decision on the matter in question. The arbitrator shall decide each and every dispute in accordance with the laws of the State of California. The arbitrator's decision and award shall be subject to review for errors of fact or law in the Superior Court for the County of Orange, with a right of appeal from any judgment issued therein.
25. **Pass-Through Damages. In the event the Contractor disposes of debris, rubbish, excess materials, or any other waste into the sewer system OC San may be subject to damages incurred as fines. Such fines may include those charged by permitting agencies or cities. The cost of these damages as validated by OC San shall be passed to the Contractor.** Contractor agrees to pay such damages and further agrees that OC San may offset the amount of these damages from any monies due or that may become due Contractor under this Contract. Contractor also agrees that to the extent the amount of these damages exceeds any monies due to the Contractor under this Contract, Contractor shall pay all such amounts to OC San upon demand.
26. **Liquidated Damages.** Not Used.
27. **Remedies.** In addition to other remedies available in law or equity, if the Contractor fails to make delivery of the goods and Services or repudiates its obligations under this Contract, or if OC San rejects the goods or Services or revokes acceptance of the goods and Services, OC San may (a) cancel the Contract; (b) recover whatever amount of the purchase price OC San

has paid, and/or (c) “cover” by purchasing, or contracting to purchase, substitute goods and Services for those due from Contractor. In the event OC San elects to “cover” as described in (c), OC San shall be entitled to recover from Contractor as damages the difference between the cost of the substitute goods and Services and the Contract price, together with any incidental or consequential damages.

**28. Force Majeure.** Neither party shall be liable for delays caused by accident, flood, acts of God, fire, labor trouble, war, acts of government, or any other cause beyond its control, but the affected party shall use reasonable efforts to minimize the extent of the delay. Work affected by a force majeure condition may be rescheduled by mutual consent of the Parties.

**29. Termination.**

29.1 OC San reserves the right to terminate this Contract for its convenience, with or without cause, in whole or in part, at any time, by written notice from OC San. Upon receipt of a termination notice, Contractor shall immediately discontinue all work under this Contract (unless the notice directs otherwise). OC San shall thereafter, within thirty (30) days, pay Contractor for work performed (cost and fee) through the date of termination. Contractor expressly waives any claim to receive anticipated profits to be earned during the uncompleted portion of this Contract. Such notice of termination shall terminate this Contract and release OC San from any further fee, cost, or claim hereunder by Contractor other than for work performed through the date of termination.

29.2 OC San reserves the right to terminate this Contract immediately upon OC San’s determination that Contractor is not complying with the Scope of Work requirements, if the level of service is inadequate, or for any other default of this Contract.

29.3 OC San may also immediately terminate this Contract for default, in whole or in part, by written notice to Contractor:

- if Contractor becomes insolvent or files a petition under the Bankruptcy Act; or
- if Contractor sells its business; or
- if Contractor breaches any of the terms of this Contract; or
- if the total amount of compensation exceeds the amount authorized under this Contract.

29.4 All OC San’s property in the possession or control of Contractor shall be returned by Contractor to OC San on demand or at the expiration or early termination of this Contract, whichever occurs first.

**30. Attorney’s Fees.** If any action at law or in equity or if any proceeding in the form of an Alternative Dispute Resolution (ADR) is necessary to enforce or interpret the terms of this Contract, the prevailing party shall be entitled to reasonable attorney’s fees, costs, and necessary disbursements in addition to any other relief to which the prevailing party may be entitled.

**31. Waiver.** The waiver by either party of any breach or violation of, or default under, any provision of this Contract shall not be deemed a continuing waiver by such party of any other provision or of any subsequent breach or violation of this Contract or default thereunder. Any breach by Contractor to which OC San does not object shall not operate as a waiver of OC San’s rights to seek remedies available to it for any subsequent breach.





38. **Entire Agreement.** This Contract constitutes the entire agreement of the Parties and supersedes all prior written or oral communications and all contemporaneous oral agreements, understandings, and negotiations between the Parties with respect to the subject matter hereof.

[Intentionally left blank. Signatures follow on the next page.]

DRAFT -  
DO NOT SUBMIT

IN WITNESS WHEREOF, intending to be legally bound, the Parties hereto have caused this Contract to be signed by their duly authorized representatives.

**ORANGE COUNTY SANITATION DISTRICT**

Dated: \_\_\_\_\_

By: \_\_\_\_\_  
Chad P. Wanke  
Chair, Board of Directors

Dated: \_\_\_\_\_

By: \_\_\_\_\_  
Kelly A. Lore  
Clerk of the Board

Dated: \_\_\_\_\_

By: \_\_\_\_\_  
Ruth Zintzun  
Purchasing & Contracts Manager

**[CONTRACTOR]**

Dated: \_\_\_\_\_

By: \_\_\_\_\_

\_\_\_\_\_  
Print Name and Title of Officer

**IG**

**EXHIBIT A**  
**SCOPE OF WORK**  
**For**  
**Manhole Rehabilitation Services**

**Exhibit A**  
**SCOPE OF WORK**  
**Manhole Rehabilitation Services**  
**SPECIFICATION NO. S-2023-1391BD**

**1 Purpose**

The Orange County Sanitation District (OC San) requires the rehabilitation of sewer manholes, and other structures. The Scope of Work (SOW) involves the rehabilitation of deteriorated, damaged, aged, corroded, and/or offset manholes using polyurethane, epoxy coating techniques. The work will also include associated tasks such as traffic control and obtaining encroachment permits. The work will take place throughout OC San's service areas.

**2 Description**

Manhole rehabilitation shall conform to subsections of the latest edition of Standard Specifications for Public Works Construction, The "Greenbook" (SSPWC).

The rehabilitation of manholes shall be accomplished using either:

- a. One hundred percent (100%) solids, plural-component applied epoxy coating (Raven 405, Madewell Mainstay DS-5 ultra-high build Epoxy, Sauereisen 210X, or approved equal).
- b. One hundred percent (100%), plural-component applied polyurethane coating (Sprayroq Spraywall, or approved equal)
- c. One hundred percent (100%), PVC applied coating (Armorlok Liner, or approved equal)
- d. One hundred percent (100%), mortar repair back original dimensions (when liner is not present)
- e. One hundred percent (100%), mortar repair back original dimensions, (Prior to application of spray liner or other approved process)
- f. Transitional or termination point epoxy (Sikadur 31, or approved equal)
- g. Use of infiltration foam grout injection as determined and approved by OC San inspector (Avanti AV-202, Sika 101AP, or approved equal)

**3 Project/Work Elements**

All field services necessary for the manhole and structure rehabilitation shall be provided by the Contractor. The work generally includes:

**3.1 General**

- 3.1.1 Obtain any required permits.
- 3.1.2 The Contractor shall submit a detailed plan for the control of fugitive dust.
- 3.1.3 The Contractor shall submit a detailed plan for the removal of loose material from the interior sides of the manholes. The plan shall include the tool and equipment to be used in the removal and cleaning process; the method to prevent the material from entering the sewer; the method for removal and disposal; and the final disposal location.
- 3.1.4 Inspection, cleaning and surface preparation of the manhole or structure prior to application of the coating system.

- 3.1.5 Provide localized repairs and patching using rapid setting mortars that are compatible with the coating system.
- 3.1.6 Prepare the surface of the concrete or masonry manhole or structure for suitable application and adhesion of the specified product.
- 3.1.7 Any active leaks of the host manhole or structure shall be eliminated prior to the application of the specified coating system.
- 3.1.8 Application of the coating system per section 500-2.7 POLYURETHANE AND EPOXY PROTECTIVE LINING SYSTEM or section 500-2.8 EPOXY LINING SYSTEM of the latest edition of the SSPWC. Application of either material, polyurethane or epoxy, to be determined by OC San, shall be achieved in one (1) continuous pass with a thickness of 125 mils (3 mm).
- 3.1.9 Inspection of the manhole or structure by OC San's Inspector following application of the coating system (See Section 13 below)
- 3.1.10 The project site shall be completely cleaned upon completion of the work and any damaged areas, structures or equipment caused by the Contractor or its subcontractors shall be repaired to OC San's satisfaction at no additional cost to OC San.

#### **4 Resources Available**

OC San will provide an inspector to ensure the work is in compliance with the Contract documents. The Contractor shall provide work site access to the OC San staff at all times. All contractor costs associated with deficient work (additional inspection, traffic control, etc.) shall be paid solely by the Contractor.

#### **5 Confined Space Entry and Safety**

The Contractor is required to have a copy of its current OC San issued confined space entry permit at every job site at all times. The OC San inspector may shut down the job site at no additional cost to OC San if the permit is not available upon request.

#### **6 Permits and Access**

Contractor shall prepare applications, submit and acquire all required permits, including traffic control, encroachment permits and any other necessary permits that may be necessary to complete the work. OC San will reimburse Contractor for permit fees upon request in writing, after demonstrating proof of payment and acceptance by the local public agency issuing the permit.

#### **7 Traffic Control**

All traffic control shall be in accordance with the latest CalTrans requirements, OC San and/or City regulations and based on the speed limits posted in the work zones. Flagmen may be required in some locations. Additional local regulations shall have precedence. Contractor shall apply for all traffic control permits. OC San shall reimburse Contractor for permit fees. Safe and adequate pedestrian and vehicular access shall be provided in accordance with the Work Area Traffic Control Handbook, at a minimum. Inadequate or improper signage and delineation for traffic control may be cause for termination of the Contract.

Standard traffic control is defined in the Bid Price Form. Any work requiring extensive traffic control will be paid on a case-by-case basis which must be approved by the Project Manager or designee before the Contractor starts work.

#### **8 Project Schedule/Work Hours**

Work hours shall be 7:00 AM to 4:30 PM Monday through Thursday, excluding OC San holidays, unless stricter work hour restrictions exist in the jurisdiction where the work is being performed. Work on Friday's will be allowable on a case-by-case basis and must be approved by OC San prior to performing work.

Contractor shall provide notification of requested workdays to the OC San Project Manager or designee and Inspector a minimum of two (2) business days before beginning work. This notification/request must be approved by the OC San Project Manager or designee or Inspector before beginning work. Performing work without this approval may be cause for termination of the Contract.

#### **9 Noise Control**

Shall follow permitting agency's guidelines and as approved by the Engineer. If applicable, multiple permits may be required.

#### **10 Odor Control**

Contractor shall furnish all labor, materials, and equipment required and shall carry out effective measures wherever and as often as necessary to prevent the discharge of nuisance odor from its operation into the atmosphere in such quantity as will violate the regulations of the South Coast Air Quality Management District and any other agency having jurisdiction.

#### **11 House Keeping and Rubbish Control**

Contractor shall keep the work area in a neat and clean condition, and free from any accumulation of rubbish and debris. The Contractor shall dispose of all rubbish and waste materials collected from the work site and shall establish regular intervals of collection and disposal of such materials and waste. Disposal of rubbish and surplus materials shall be at the Contractor's expense and done in accordance with all Federal, State, and local, codes and ordinances governing locations and methods of disposal, and in conformance with all applicable safety laws, and the requirements of the Cal/OSHA and OC San Safety Standards.

Note: Disposal of any debris, rubbish, excess materials, or any other waste into the sewer system may be cause for the termination of the Contract and possible penalties.

#### **12 Warranty**

Contractor shall warrant all work against defects in materials and workmanship for a period of not less than five (5) years, unless otherwise noted, from the date of final acceptance of the repair. Contractor shall, within a reasonable time (within 90 calendar days) after receipt of written notice, repair defects in materials and workmanship which may develop during the warranty period, and any damage to other work caused by such defects at its sole expense and without any additional cost to OC San.

An OC San Inspector shall conduct the testing. The Inspector shall observe and document warranty repairs to ensure adherence to the requirements of the Contract documents. All work shall be done to the satisfaction of the Inspector.

OC San may, at its sole discretion, choose to perform holiday testing and bond strength testing within the warranty period. Any defects found in materials or workmanship as warranted shall be corrected by the Contractor at no additional cost to OC San.

### **13 Testing and Inspection**

Testing and inspection shall be conducted by OC San's Inspector. Any portion of the coating that does not satisfactorily pass the inspection and testing requirements shall be repaired or replaced by the Contractor at no additional cost to OC San. Additional testing and/or inspection may be done at the discretion of OC San.

- A. Preparation Inspection: The Contractor shall notify the OC San Project Manager or designee and the Inspector of the time and date for inspection and approval two (2) business days prior to completing the surface preparation of each manhole and prior to application of the coating.
- B. The moisture content in the concrete prior to application shall be less than that recommended by the manufacturer. The Inspector may use a "blotter test", or other test method to determine the moisture content.
- C. Thickness Testing: During application a wet film thickness gage, such as those available through Paul N. Gardner Company, Inc., or approved equal, meeting ASTM D4414 (or current ASTM Standards) - Standard Practice for Measurement of Wet Film Thickness of Organic Coatings by Notched Gages, or approved equal, may be used to ensure a monolithic coating and uniform thickness during application.
- D. Holiday Testing (Spark Testing): Contractor is responsible for the Holiday Testing (Spark Test) and OC San shall witness the test. After the protective coating has set hard to the touch it shall be inspected with a currently calibrated high-voltage holiday detection equipment. Surfaces shall first be dried; an induced holiday shall then be made on to the coated concrete surface and shall serve to determine the minimum/maximum voltage to be used to test the coating for holidays at that particular area. The spark tester shall be initially set at 100 volts per 1 mil (25 microns) of film thickness applied but shall be adjusted as necessary to detect the induced holiday (refer to NACE SP0188-2006). All detected holidays shall be marked and repaired by abrading the coating surface with grit disk paper or other hand tooling method. After abrading and cleaning, additional protective coating material can be hand applied to the repair area. All touch-up/repair procedures shall follow the protective coating manufacturer's recommendations.
- E. Measurement of bond strength of the protective coating to the substrate shall be made in accordance with ASTM D4541 (or current ASTM Standards) and is the responsibility of the contractor. The test shall be performed by a qualified technician. The number of manholes and locations inside the manholes to be tested shall be determined by OC San after application of coating. Each manhole tested shall have one or more 20 mm dollies fixed and pulled in accordance with ASTM D4541 (or current ASTM Standards), using an Elcometer instrument. The adhesion pulls shall exceed 200 psi or concrete failure with more than fifty percent (50%) of the subsurface adhered to the coating. For each test that fails, two (2) additional tests shall be performed in the same manhole at locations chosen by OC San. Further



bond tests may be performed by OC San to determine the extent of potentially deficient bonded areas. The Contractor shall repair all bond strength test sites in accordance with the manufacturer's recommendations. If two (2) consecutive dollies in the same manhole fail, the liner shall be removed and replaced at the expense of the Contractor.

F. Visual Inspection: A visual inspection shall be made by the OC San Inspector using the latest NASSCO standard inspection form (if available) or OC San's inspection form. Any deficiencies in the finished coating shall be marked and repaired according to the procedures set forth herein.

G. All hold points determined by OC San inspection are to be discussed, understood, and followed by the contractor. Hold points include before and after repair inspection.

#### **14 Staff Assistance**

The Contractor will be assigned a single point of contact for this Contract. Any meetings and/or correspondence related to this Contract shall be scheduled and approved by the OC San Project Manager or designee.

April 5, 2023

**ADDENDUM #2**  
**NOTICE TO BIDDERS**

**SPECIFICATION NO. S-2023-1391BD**  
**Manhole Rehabilitation Services**

➤ **QUESTION CUT-OFF DATE: March 21, 2023 at 2:00 P.M. PT**  
➤ **BID SUBMITTAL DATE: April 12, 2023 at 2:00 P.M. PT**

The following additions, modifications, corrections, deletions, and clarifications are hereby made to the bid document named above.

**ADDITIONS**

Please see attached detailed drawings (S-049 and S-060) that provide additional structure information (5 pages).

**QUESTIONS**

- 1 Question: Is a confined space rescue team required to be on site during the performance of the work outlined in the specifications?
- Answer: Yes, a rescue team member needs to be onsite during confined space entry. Confined space entry under this contract is permit-required (whether it be an entry or non-entry rescue). For an entry-rescue, you may use your own qualified rescuers or use an outside rescue service. Also, being that this will be a live sewer line, you'll need to include a ventilation plan or indicate SCBA use in their CS Entry Plan.**
- 2 Question: Can the District please clarify what type of diversion slots will be needed. Hand operated slide gate or wheel operated.
- Answer: OC San utilizes hand operated slide gates.**

- Serving:
- Anaheim
  - Brea
  - Buena Park
  - Cypress
  - Fountain Valley
  - Fullerton
  - Garden Grove
  - Huntington Beach
  - Irvine
  - La Habra
  - La Palma
  - Los Alamitos
  - Newport Beach
  - Orange
  - Placentia
  - Santa Ana
  - Seal Beach
  - Stanton
  - Tustin
  - Villa Park
  - County of Orange
  - Costa Mesa Sanitary District
  - Midway City Sanitary District
  - Irvine Ranch Water District
  - Yorba Linda Water District

3 Question: Can the district provide a detail for the Manhole Bench Replacement, one with and one without the diversion slot?

**Answer: Please see attached detailed drawings (S-049 and S-060) that provide additional structure information. Please note, not all benches are the same. This is a general guideline and final say will be completed in the field with the OC San inspections team.**

Jeremy Arbiso  
Contract, Purchasing & Materials Management

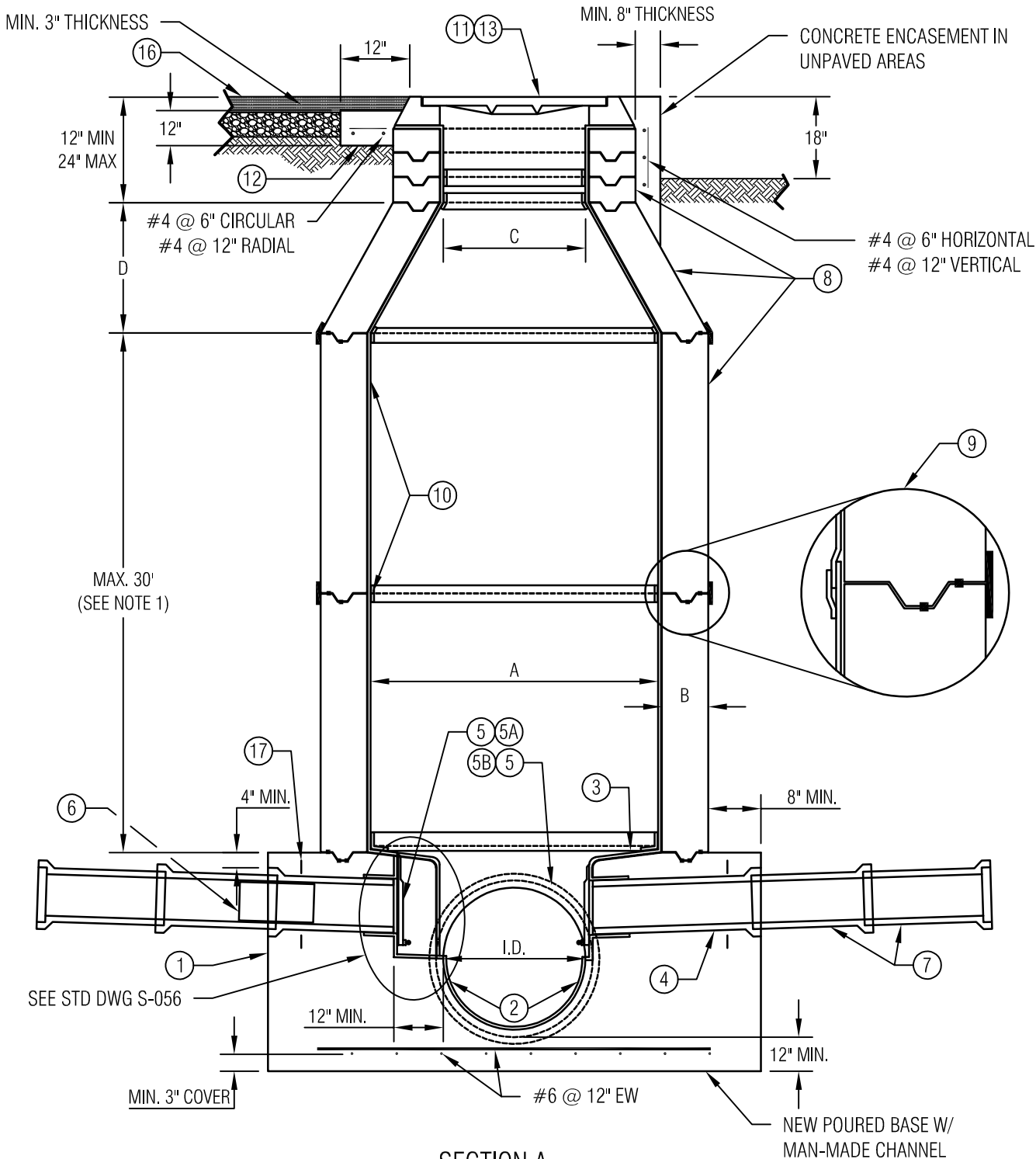

**NOTE:**

1. MANHOLE DEPTH GREATER THAN 30', DIMENSION 'A' PER PLANS. SEE PLANS FOR PIPE SIZES OVER 54".
2. MANHOLE BEDDING SHALL BE MIN. 12" ROCK BEDDING OR APPROVED EQUAL.

PIPE SIZE (I.D.)	A	B	C	D
8"- 24"	60"	6"	36"	24"
27"- 36"	72"	7"	36"	32"
39"- 54"	84"	8"	36"	48"

DWG: J:\CAD Standards\WIP\_Engineering Standard Drawings\REVISED\S-049\_1 - NEW PVC LINED MANHOLE OVER EXISTING SEWER 1 OF 3.dwg  
 DATE: Apr 01, 2019 2:48pm

NO.	APPROVED	DATE

ORANGE COUNTY SANITATION DISTRICT  
 ORANGE COUNTY, CALIFORNIA  
 APPROVED BY  
  
 DIRECTOR OF ENGINEERING  
 DATE: 5/20/18

**NEW PVC LINED MANHOLE  
 OVER EXISTING SEWER**  
 1 OF 3

NO SCALE  
 STANDARD DWG.  
**S-049**

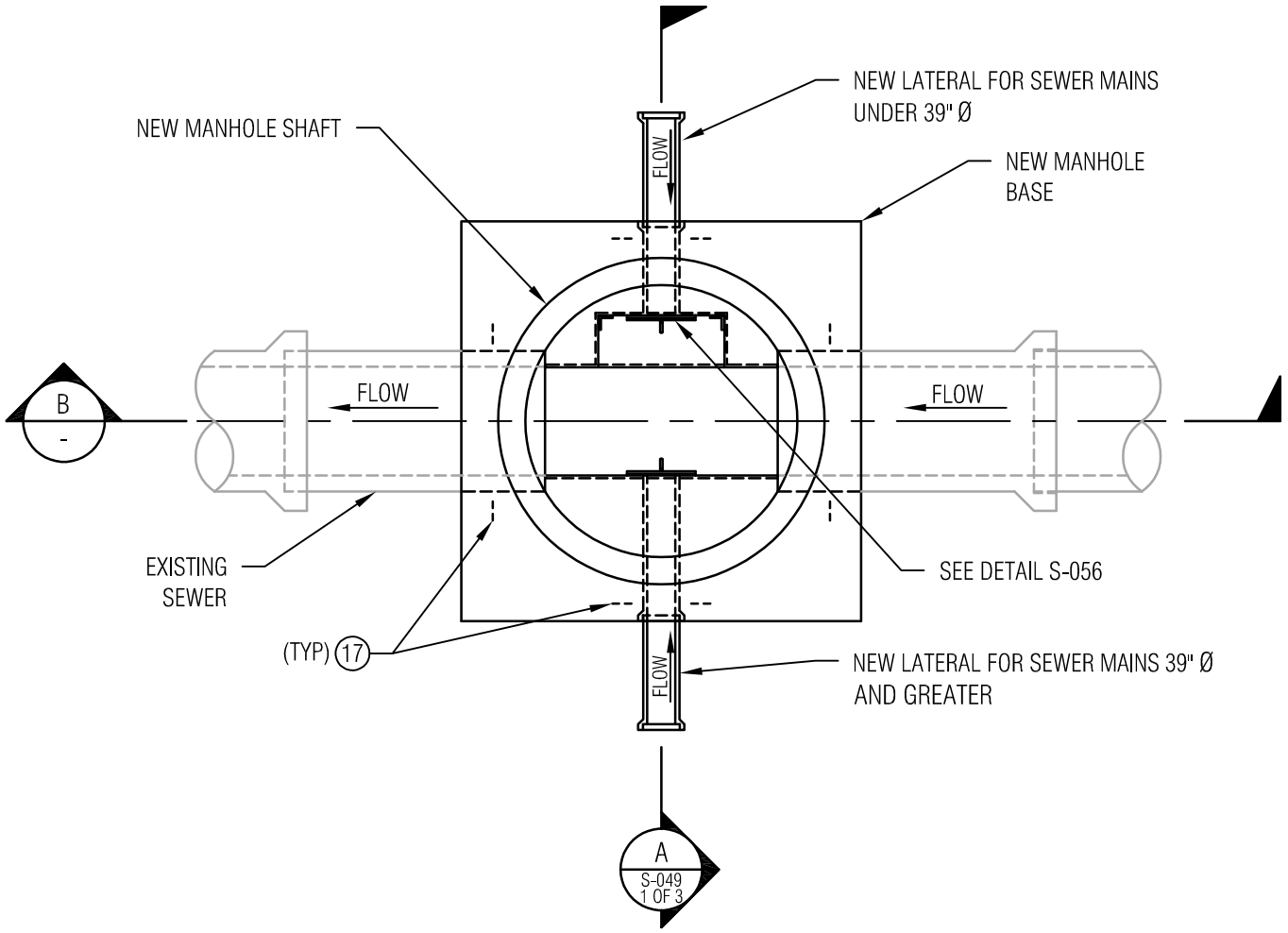

PLAN VIEW

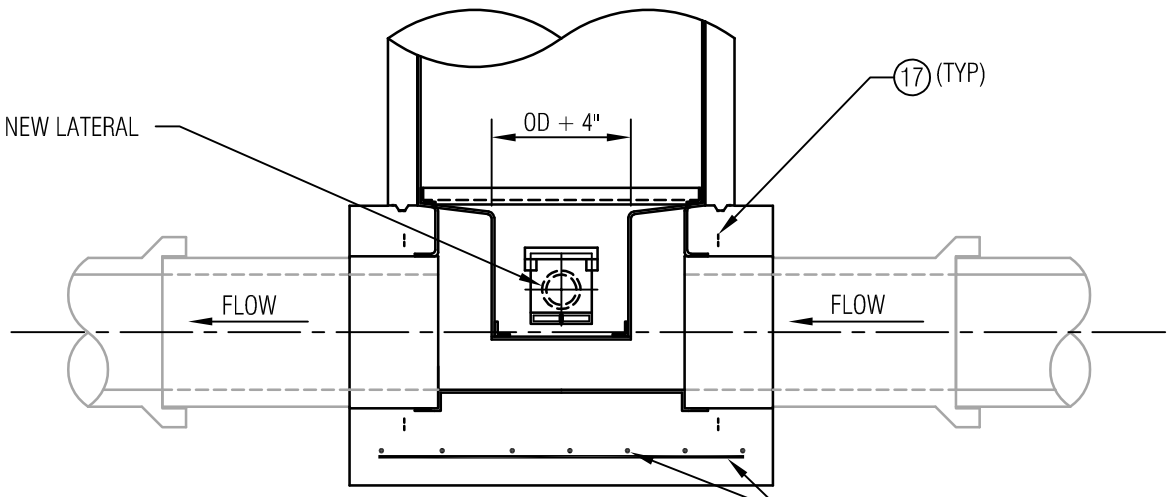

SECTION B

DWG: J:\CAD Standards\WIP\WIP\_Engineering Standard Drawings\REVISED\S-049\_2 - NEW PVC LINED MANHOLE OVER EXISTING SEWER 2 OF 3.dwg  
 DATE: Apr 02, 2019 7:05am

NO.	APPROVED	DATE

ORANGE COUNTY SANITATION DISTRICT  
 ORANGE COUNTY, CALIFORNIA  
 APPROVED BY  
  
 DIRECTOR OF ENGINEERING  
 DATE: 5/20/18

**NEW PVC LINED MANHOLE  
 OVER EXISTING SEWER**  
 2 OF 3

NO SCALE  
 STANDARD DWG.  
**S-049**

**NOTES:**

- ① MANHOLES SHALL HAVE 4000 # (CLASS "A"), CONCRETE BASES WITH #6 (19 MM) BARS @ 12" E.W. SIDES OF BASE SHALL BE FORMED BY EITHER WOOD FORMS OR SANDBAGS. BASE MAY BE EITHER CIRCULAR OR RECTANGULAR. IF CIRCULAR, THE AREA SHALL BE EQUAL TO THE AREA OF THE SQUARE BASE. ALL CONCRETE AND MORTAR SHALL USE CLASS II/V CEMENT.
- ② THE BASE'S CHANNEL SHALL BE CONSTRUCTED WITH FORMS AND PVC LINED. WHERE PVC LINED RCP IS USED, THE CHANNEL'S LINING IS TO BE INSTALLED TO THE SAME DEPTH AS THE RCP LINING. THE EXISTING PIPE SHALL BE REMOVED BY SAW CUTTING. THE REMOVED SECTION SHALL BE OF A LENGTH THAT THE ENDS OF THE REMAINING PIPE AT ITS SPRINGLINE IS FLUSH WITH THE MANHOLE'S SHAFT INSIDE DIAMETER.
- ③ MANHOLE SHELVES SHALL BE SLOPED 1/4" PER FOOT TO CHANNEL AND COVERED WITH PVC LINER WITH LOCKING EXTENSIONS. INSTALL NON-SKID SURFACE ON PVC LINER OVER THE COMPLETE MANHOLE SHELF ON BOTH SIDES OF MAIN CHANNEL PER THE SPECIFICATION OR APPROVED LINER MANUFACTURER RECOMMENDATIONS. A PVC ANGLE STRIP SHALL BE USED FOR THE TRANSITION BETWEEN HORIZONTAL SHELF AND VERTICAL CHANNEL.
- ④ INSTALL AT LEAST TWO LATERAL INLET PIPES IN THE MANHOLE BASE AS SHOWN. IF NOT SHOWN, LATERAL PIPING SHALL BE 8" VCP AT 90° TO THE MAIN CHANNEL AND SLOPED AT 1/4" PER FOOT FROM THE OUTSIDE OF THE MANHOLE BASE TO THE CHANNEL WHERE THE CHANNEL ANGLES MORE THAN 45° TOWARD A SIDE, THAT SIDE LATERAL IS NOT REQUIRED.
- ⑤ THE SOFFIT OF ALL LATERAL PIPES SHALL BE AT THE SAME ELEVATION AS THE MAIN PIPE SOFFIT. ALL LATERAL INLETS 12" DIAMETER AND SMALLER SHALL HAVE PVC WELDED GAS FLAPS INSTALLED SIMILAR TO DRAWING S-056, UNLESS OTHERWISE NOTED BY THE ENGINEER. PVC LINER SHALL BE PLACED THROUGHOUT THE CHANNEL AND PVC TURN BACK ON VCP OR OTHER PIPE SHALL BE A MINIMUM OF 6".
- ⑤A FOR MANHOLE BASES WHERE MAIN SEWER PIPE IS LESS THAN 39" IN DIAMETER, THE LATERALS SHALL BE RECESSED 12" MINIMUM FROM MAIN LINE CHANNEL WITH A TROUGH IN THE BENCH SLOPING TO THE MAIN CHANNEL.
- ⑤B FOR MANHOLE BASES WHERE MAIN SEWER PIPE IS 39" AND GREATER IN DIAMETER, THE END OF THE LATERAL IS FLUSH WITH THE CHANNEL.
- ⑥ ALL UNUSED CONNECTIONS SHALL HAVE A FACTORY MADE VCP PLUG INSTALLED IN THE BELL END OF THE PIPE WITH RESTRAINT SUFFICIENT TO WITHSTAND LEAKAGE TESTING. PIPE OVER 21" SHALL USE A BRICK AND MORTAR PLUG.
- ⑦ EACH MAIN LINE OR LATERAL CONNECTION TO THE MANHOLE BASE SHALL HAVE TWO EACH, TWO FOOT JOINTS.
- ⑧ MANHOLE SECTIONS AND GRADE RINGS SHALL BE REINFORCED, MADE FROM CLASS II/V CEMENT AND CAST WITH PVC LINER PLATE ON INSIDE. ECCENTRIC CONE SHALL BE SET WITH STRAIGHT SIDE ON DOWNSTREAM SIDE OF MANHOLE. ECCENTRIC REINFORCED CONCRETE FLAT TOPS MAY BE USED WHEN APPROVED BY THE ENGINEER.
- ⑨ THE KEYLOCK JOINT BETWEEN MANHOLE SECTIONS SHALL BE SEALED WITH TWO 1-1/4" SQUARE BEADS OF RAM-NEK BY HENRY COMPANY, KENT-SEAL BY HAMILTON KENT, OR APPROVED EQUAL. THE MASTIC BEADS SHALL BE PLACED ON THE OUTSIDE SHOULDER OF AND IN THE GROOVE. APPLY A 6" MINIMUM WIDTH OUTSIDE JOINT WRAP, RUB'R-NEK BY HENRY COMPANY, SEAL WRAP BY SEALING SYSTEMS, INC., OR EQUAL, TO ALL SHAFT JOINTS. GRADE RING JOINTS SHALL BE MORTAR.
- ⑩ INSTALLATION OF PVC LINER PLATE SHALL CONFORM TO THE REQUIREMENTS OF SECTION 06620 OF THE SPECIFICATIONS. USE WELDING STRIPS AT PVC JOINTS, A PREFORMED CORNER WELDING STRIP AT THE BASE JOINT AND A CONTINUOUS PREFORMED CORNER AT THE TOP GRADE RING AND FRAME JOINT TO THE SECOND GRADE RING.
- ⑪ INSTALL FRAME AND COVER PER STANDARD DRAWING S-055. ADJUSTMENT SHALL OCCUR USING MORTAR BETWEEN FIRST AND SECOND GRADE RINGS. THE FRAME SHALL COMPLETELY BEAR ON PVC. CAULK THE JOINT BETWEEN THE FRAME AND THE PREFORMED PVC CORNER AT THE TOP GRADE RING WITH SIKAFLEX 1A OR EQUAL.
- ⑫ PLACE CONCRETE COLLAR IN PAVED AREAS AS SHOWN AFTER PLACEMENT OF ASPHALT. SEE DRAWING S-055. MANHOLES PLACED IN UNPAVED AREAS SHALL HAVE THE COVERS PLACED 18" ABOVE FINISHED GRADE. EXPOSED CONCRETE SHALL BE FINISHED AND COATED SAFETY YELLOW.
- ⑬ MANHOLES IN INTERSECTIONS SHALL HAVE BOLTED COVERS.
- ⑭ VACUUM TESTING SHALL BE PERFORMED PER ASTM C-1244 UNLESS NOTED OTHERWISE.
- ⑮ MANHOLES SHALL BE BACKFILLED WITH 1-1/2 SACK SAND/CEMENT SLURRY TO STREET ZONE OR AS REQUIRED BY LOCAL AGENCY.
- ⑯ IN PAVED AREAS, PAVEMENT AND BASE COURSE SHALL BE REPLACED IN KIND, UNLESS OTHERWISE NOTED BY THE GOVERNING AGENCY.
- ⑰ INSTALL A WEEP RING AT VCP/HDPE PENETRATIONS WITH HIGH GROUND WATER CONDITIONS.

DWG.: J:\CAD Standards\WIP\WIP\_Engineering Standard Drawings\REVISED\S-049\_3 - NEW PVC LINED MANHOLE OVER EXISTING SEWER 3 OF 3.dwg  
DATE: Apr 02, 2019 7:21am

			ORANGE COUNTY SANITATION DISTRICT ORANGE COUNTY, CALIFORNIA APPROVED BY  DIRECTOR OF ENGINEERING	<b>NEW PVC LINED MANHOLE          OVER EXISTING SEWER          3 OF 3</b>	NO SCALE STANDARD DWG. <b>S-049</b>
NO.	APPROVED	DATE	DATE		

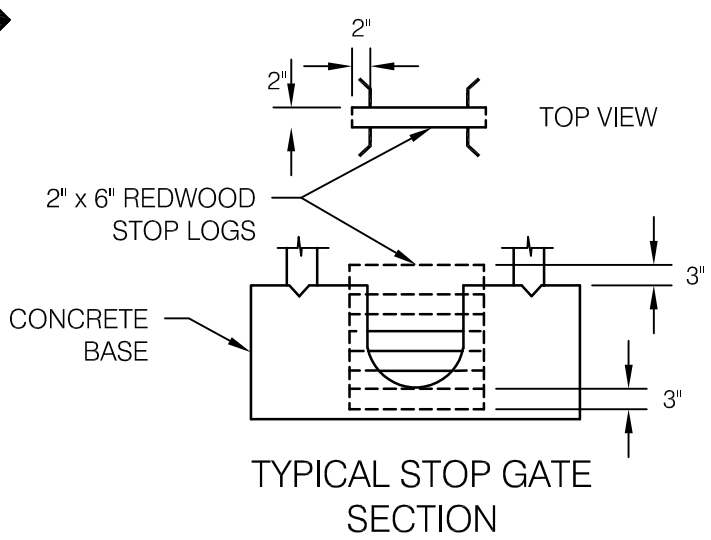
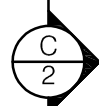
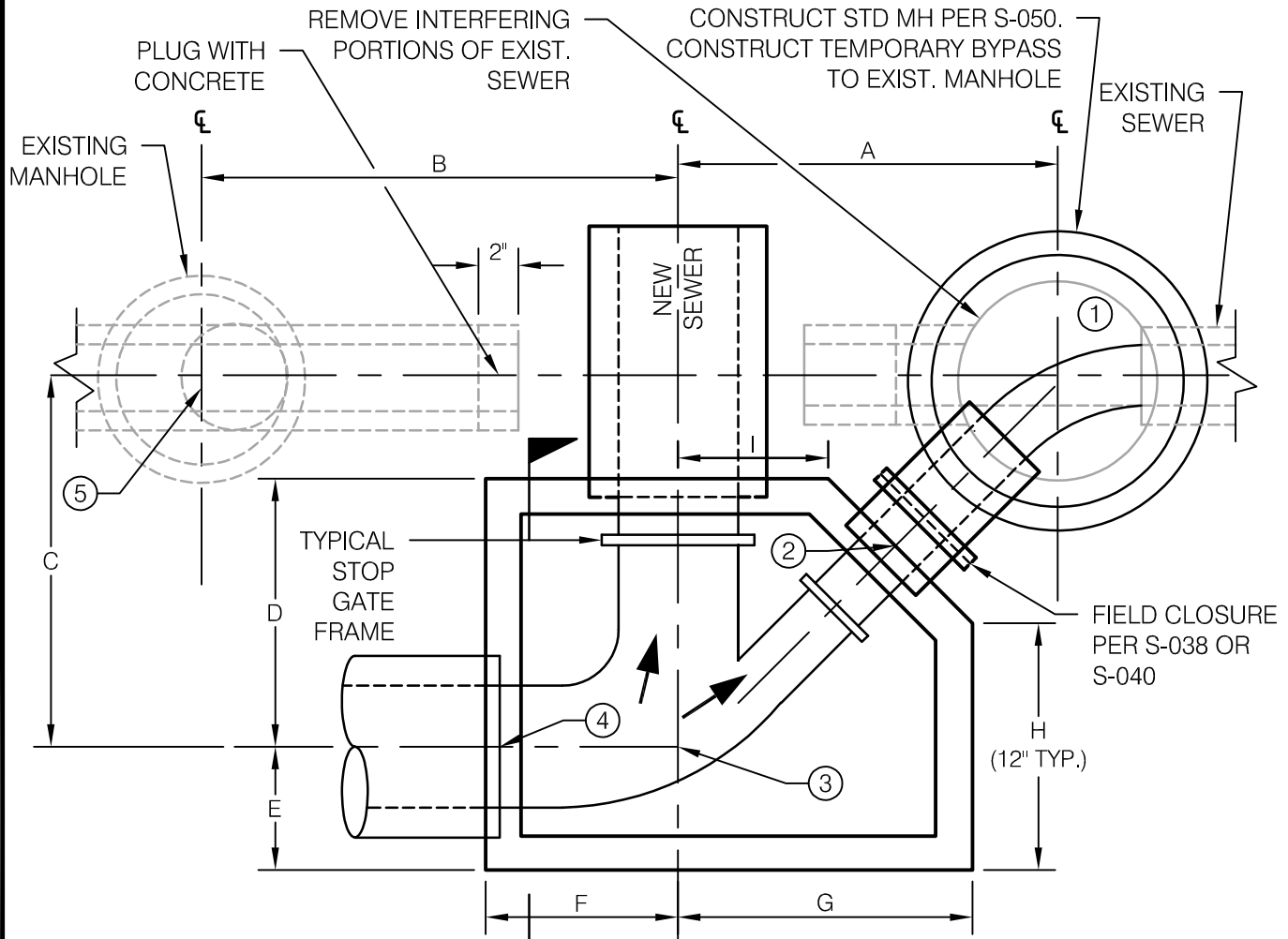

**NOTES:**

1. DIMENSIONS A, B, C, D, E, F, G, H, AND I SHALL BE AS SHOWN ON THE PLANS.
2. ELEVATIONS ①, ②, ③, ④, AND ⑤ SHALL BE AS SHOWN ON PLANS.
3. TYPICAL STOP GATE SHALL BE INCLUDED IN ALL DIVERSION STRUCTURE INSTALLATIONS.
4. FOR SECTIONS, SEE S-060 SHEET 2 OF 2.

DWG: J:\CAD Standards\WIP\WIP\_Engineering Standard Drawings\REVISED\S-060\_1 - DIVERSION STRUCTURE WITH STOP GATE SHEET 1 OF 2.dwg  
 DATE: May 15, 2019 8:45am

			ORANGE COUNTY SANITATION DISTRICT ORANGE COUNTY, CALIFORNIA APPROVED BY DIRECTOR OF ENGINEERING	<b>DIVERSION STRUCTURE          WITH STOP GATE          SHEET 1 OF 2</b>	NO SCALE STANDARD DWG. <b>S-060</b>
NO.	APPROVED	DATE	DATE		

WHEN D IS LESS THAN 12"  
USE FULL DEPTH AC PAVING  
OVER JUNCTION STRUCTURE

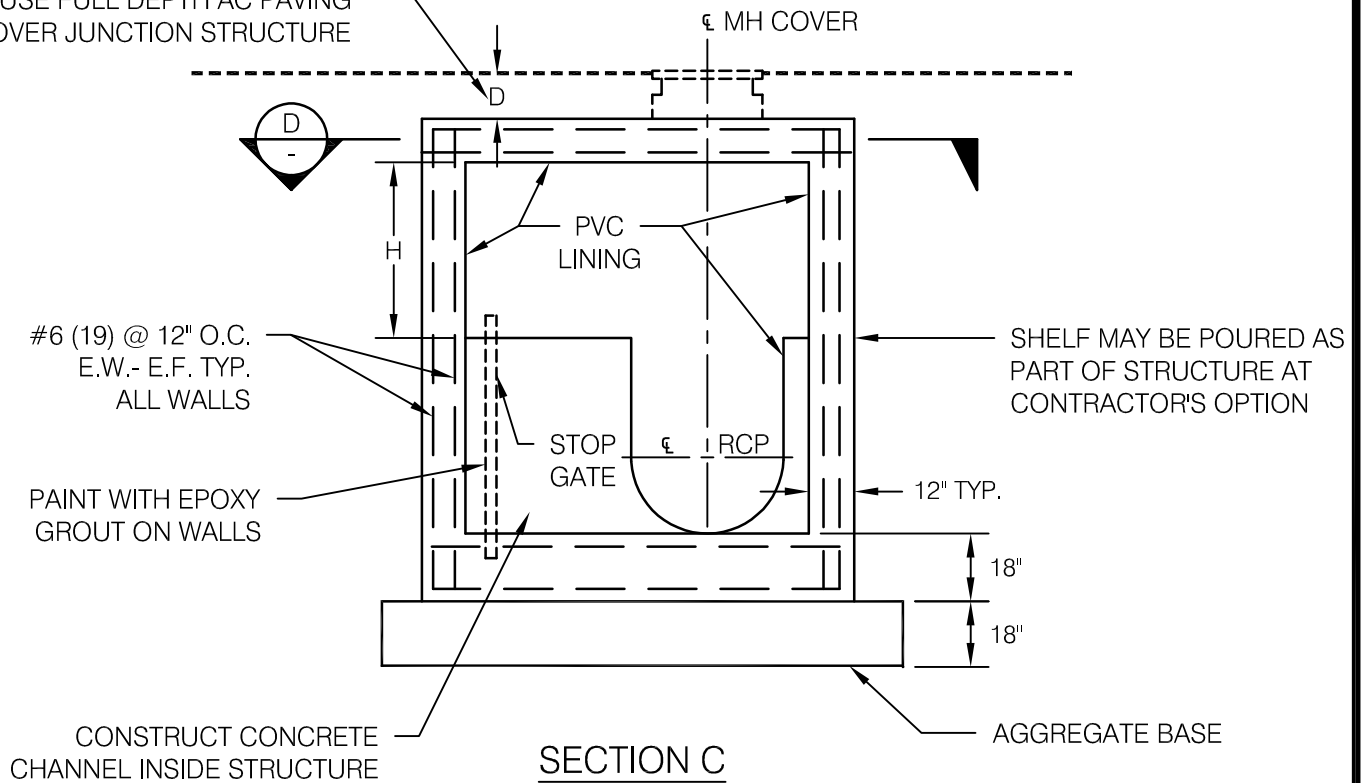

**SECTION C**

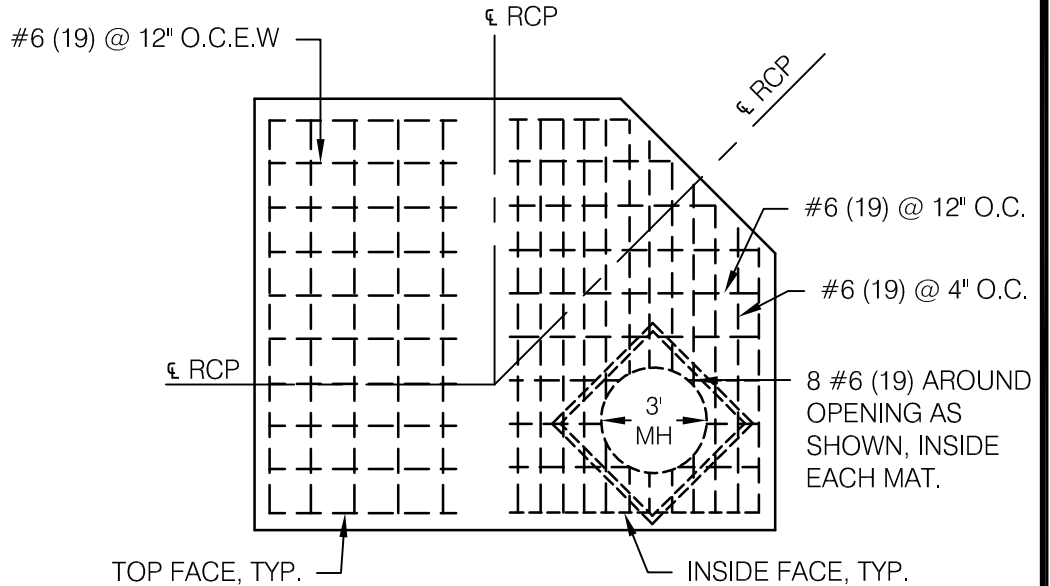

**SECTION D**

**NOTES:**

1. ALL CONCRETE SHALL BE 4000 PSI (CLASS "A").
2. REINFORCING STEEL SHALL CONFORM TO ALL REQUIREMENTS OF THE STANDARD SPECIFICATIONS.
3. HEIGHT H SHALL NOT BE LESS THAN 7'-0" UNLESS OTHERWISE APPROVED BY THE ENGINEER.

**TOP SLAB ONLY**

( ) DENOTES  
METRIC  
SYSTEM

DWG: J:\CAD Standards\WIP\WIP\_Engineering Standard Drawings\REVISED\S-060\_2 - DIVERSION STRUCTURE WITH STOP GATE SHEET 2 OF 2.dwg  
DATE: Apr 04, 2019 3:18pm

			ORANGE COUNTY SANITATION DISTRICT ORANGE COUNTY, CALIFORNIA		<b>DIVERSION STRUCTURE WITH STOP GATE SHEET 2 OF 2</b>	NO SCALE	
			APPROVED BY <i>Herby</i> 06/20/07 DIRECTOR OF ENGINEERING			STANDARD DWG.	
NO.	APPROVED	DATE					<b>S-060</b>